

- Per maggiori dettagli fare riferimento al foglio istruzioni
- For more details, refer to the technical leaflet
- Pour plus de détails, vous référer à la brochure technique dans le paquet.
- Für weitere Details siehe die Betriebsanleitung in der Verpackung.
- Para mayor detalle adjuntamos dentro un folio de instrucciones.

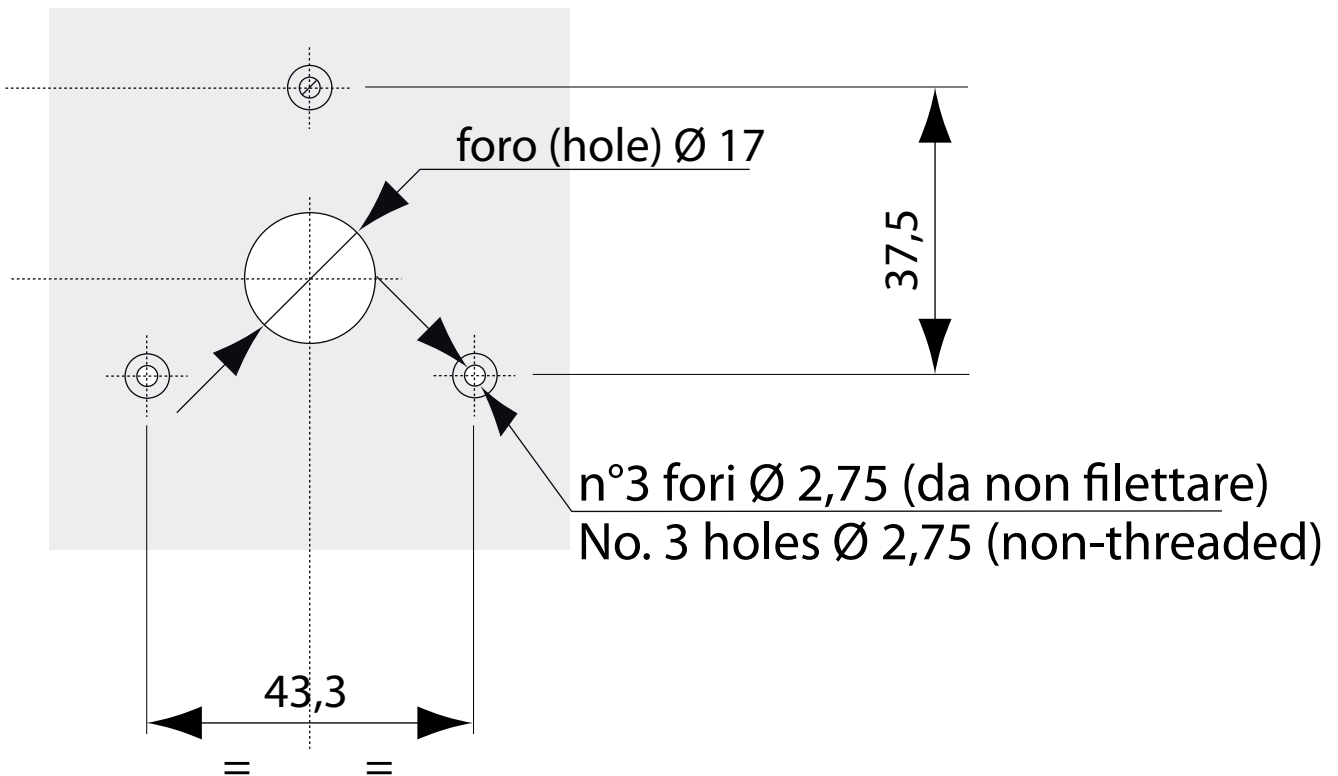
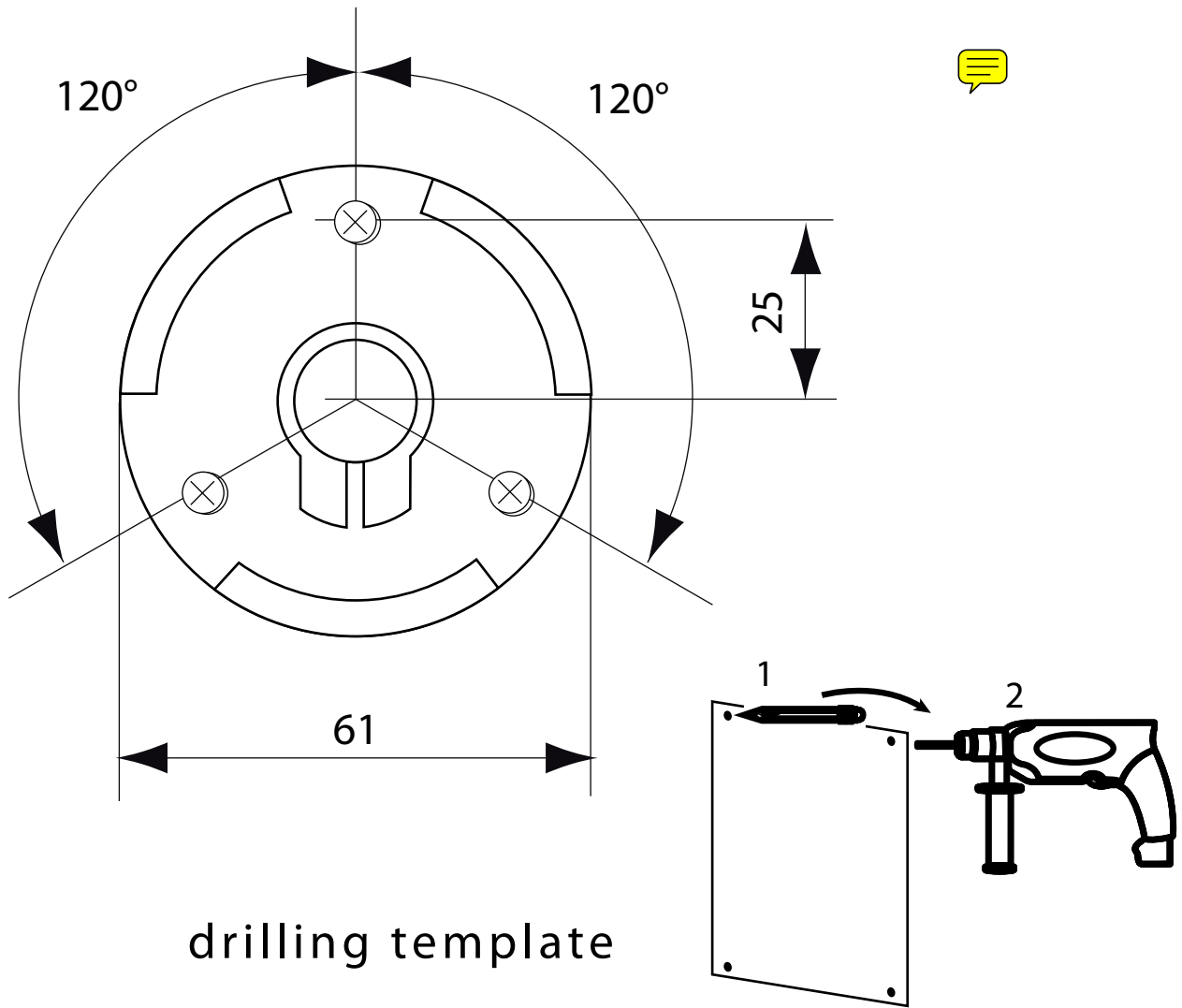

- Per maggiori dettagli fare riferimento al foglio istruzioni
- For more details, refer to the technical leaflet
- Pour plus de détails, vous référer à la brochure technique dans le paquet.
- Für weitere Details siehe die Betriebsanleitung in der Verpackung.
- Para mayor detalle adjuntamos dentro un folio de instrucciones.