

humiSteam

加湿器/humidifiers

CAREL



Ⓡ 用户手册
Ⓡ User manual

→ 阅读并保存这些用法说明 ←
**READ AND SAVE
THESE INSTRUCTIONS**

Integrated Control Solutions & Energy Savings

重要提示



CAREL加湿器是具有先进技术的产品，随产品一同提供的技术资料中有详细的操作说明，用户也可从www.carel.com网站下载说明（购买产品前也可下载）。

CAREL的每一款产品均涉及先进技术，所以均需要设置/配置/编程/调试，以使其能以最佳方式运转，满足特定应用需求，若不能按照用户手册的要求/说明完成上述各项操作，可能会导致最终产品出现故障。这种情况下，CAREL不承担任何责任。

为了使特定的装置和/或设备最终能达到预期的效果，用户（设备最终的制造商、开发商或安装人）要承担与产品配置相关的所有风险和责任。CAREL会根据特定的协议，以顾问身份参与最终设备/应用的调试，但在任何情况下，均不承担最终设备/系统正确运转的责任。

此外，除上述提到的警告和建议外，还应注意以下事项以正确的使用产品：

1、电击危险

加湿器包含了带电的电子部件。在打开内部结构或维护和安装前请先断开电源。

2、漏水危险

加湿器自动地和持续的灌入/排出一定数量的水。连接的故障或加湿器故障都可能导致漏水。

3、燃烧危险

加湿器包含了高温部件，并且传送100°C/212°F的蒸汽。

重要提示：

- 本产品的安装必须做接地处理，在加湿器上使用专用的黄色-绿色接线端。
- 产品使用环境和电源条件必须遵照产品标签上描述的条件。
- 本产品是专门为直接或通过分配系统（风道）加湿室内而设计的。
- 设备操作必须是由熟悉产品必要的预防措施，并且能完成正确安装、运行或对产品进行技术服务的有资质的人员进行。
- 蒸汽生产只能使用具备本手册中指示的特征的水。
- 所有的工作都必须按照手册中和产品标签上指示的规范进行。任何未得到制造商授权的使用或修改都被认为是不正确的。CAREL不承担任何未授权使用责任。
- 请勿尝试用本手册中未指示的其它方式打开加湿器。
- 请遵守加湿器安装地的实际法规标准。
- 确保加湿器安装在儿童或动物不能触碰到的地方。
- 加湿器的安装和使用不要靠近可能会因为碰到水（或冷凝水）而损坏的物品，不承担任何由于加湿器漏水导致的直接或间接的损坏责任。
- 请勿使用腐蚀性化学品、溶剂或强力清洁剂清洁加湿器内部和外部部件，除非本手册中专门指示了可以使用。
- 请勿摔落、击打或摇晃加湿器，因为加湿器内部构件和管路可能会永久性损坏。

CAREL奉行持续发展的方针，因此，对于本文档中所描述的任何产品，CAREL均保留不经事先通知而进行改良和改进的权利。本手册所列的技术规范可能会在不事先告知用户的情况下发生改变。

CAREL的通用合同条款（见网站www.carel.com）和/或其与客户签订的具体协议已对CAREL就其产品应负的责任作出具体规定。具体而言，在可采用的法规所适用的区域，对于任何损失的赢利或销售额、数据或资料丢失、重置商品或服务成本、物或人的损害、停工时间或任何类型的直接的、间接的、附带的、实际的、惩罚性的、惩戒性的、特别的或后果性的损害（无论其是属于合同之内或合同之外的、也无论

其是否由于疏忽引起的），或对于由于安装、使用或无法使用产品引起的任何其他责任，CAREL及其雇员或其子公司概不承担责任，即使CAREL或其子公司已被告知存在此等损害之可能。

废弃物处理



CAREL加湿器是由金属部件和塑料部件组成。参照2003年1月27日发布的欧盟指令2002/96/EC和有关国家的法律进行处理，并注意：

- 1.WEEE不能作为市政废物处理，必须收集并分开处理。
- 2.必须使用当地法律规定的公共或私人废物收集系统。此外，在购买新设备时，可以将使用寿命已尽的旧设备送还销售商。
- 3.本设备可能含有有害物质：使用或者处理不当可能会给人身健康和环境造成不利影响。
- 4.设备本身、包装物或者操作手册上的符号（划叉的轮式垃圾箱）表示设备已于2005年8月13日后投放市场，必须单独处理。
- 5.非法处理电气和电子废弃物的行为将按当地废弃物处理法规进行处罚。

材料质保：2年（自生产日期开始，不包括损耗部件）。

认证：CAREL已通过ISO 9001设计和生产系统认证，产品的质量和安全都有保障，带有CE标记。



目录

1. 产品简介和组装	7	9. 维护和部件	22
1.1 humiSteam (UEY*)	7	9.1 型号UE005 - UE015的加湿器部件	22
1.2 尺寸和重量	7	9.2 型号UE025 - UE065的加湿器部件	24
1.3 打开包装	7	9.3 清洁和维护加湿桶	26
1.4 定位	7	9.4 机械地排出加湿桶内的水	26
1.5 墙面安装	7	9.5 加湿桶连接, 三相型UE025 - UE065	26
1.6 拆下前盖板	8	9.6 清洁和维护其它部件	27
1.7 固定前盖板	9		
1.8 配件和附件	9	10. 电路图	27
2. 水路连接	10	10.1 UE005 - UE015三相加湿器电路图	27
2.1 供水	11	10.2 UE025 - UE065 三相加湿器电路图	28
2.2 排水	11		
3. 蒸汽分配器	12	11. 总体特点和型号	29
3.1 CAREL 喷射式分配器 (SDPOEM00**)	12	11.1 humiSteam型号和电气规格	29
3.2 安装在风道内的CAREL线性分配器 (DP***DRO)	12	11.2 技术规格	30
3.3 CAREL 送风式蒸汽分配器 (VSDU00A*, 仅适用于型号为UE005 - UE015 的加湿器)	12	11.3 蒸汽软管类型	30
3.4 蒸汽软管	13	11.4 集中喷气式蒸汽分配器型号	31
3.5 冷凝排水软管	13	11.5 线性分配器型号和典型安装	31
		11.6 参数表b1	33
4. 电气连接	14	11.7 通过网络控制主板	37
4.1 准备布线	14	11.8 用变量I62和I63控制蒸汽生产	38
4.2 电源线连接	14	11.9 通过网络读取报警纪录	38
4.3 蒸汽生产控制信号 (M2.1 - M2.7)	14	11.10 网络通讯失败	38
4.4 报警触点 (M5.1 - M5.2)	16	11.11 UEY控制板上的Modbus®协议	38
4.5 辅助触点: 生产请求, 外置风扇控制 (M14.1 - M14.3)	16	11.12 例外管理	38
		12. 高级功能	39
5. 远程终端和监控网络	16	12.1 运行原理	39
5.1 远程显示终端	16	12.2 控制原理	39
5.2 RS485监控网络 (M1.1-M1.3)	16	12.3 供水电导率	39
		12.4 自动排水	39
6. 启动和用户界面	17	12.5 供水不足自动管理	40
6.1 开启	17	12.6 报警继电器开关	40
6.2 停机	17	12.7 辅助触点管理 (风机)	40
6.3 显示屏	17	12.8 手动程序	40
6.4 按键	17	12.9 控制板上的LED灯	40
6.5 主界面	17		
6.6 禁用	18		
6.7 恢复工厂默认设置	18		
6.8 软件版本显示	18		
6.9 开关量对应 (主板软件与连接端的对应)	18		
6.10 复位小时和比率计时器	18		
6.11 参数: 保存/恢复用户设置	18		
6.9 手动排出加湿桶内的水	18		
7. 设置参数	19		
7.1 进入和设置参数	19		
7.2 基本参数	19		
7.3 高级参数	19		
7.5 只读参数	19		
8. 报警	20		

1. 产品简介和组装

1.1 humiSteam (UEY*)

具有背光显示屏，用于控制蒸汽的分配的等温型浸入式电极加湿器系列。

可供的型号（可从产品上的代码识别）：

- 型号UE005, UE008, UE010, UE015, 蒸汽生产量最大到 15 kg/h, 水路连接在加湿器底部；
- 型号UE025, UE035, UE045, UE065, 蒸汽生产量从25 - 65 kg/h, 水路连接在加湿器侧边。

1.2 尺寸和重量



图1.a

		UE005 - UE008	UE010 - UE015	UE025 - UE045	UE065
尺寸 mm (")	A	365 (14.4)	275 (10.8)	545 (21.5)	635 (25.0)
	B	275 (10.8)	17 (0.7)	375 (14.8)	465 (18.3)
	C	712 (28.0)	815 (32.0)	890 (35.0)	
重量 kg (lb)	包装后	16 (35.3)	20 (44.0)	39 (86.0)	51 (112.4)
	空机	13,5 (29.8)	17 (37.5)	34 (74.9)	44 (97.0)
	安装后*	19 (41.9)	27 (59.5)	60,5 (133.4)	94 (207.2)

表1.a

*: 在工作状态

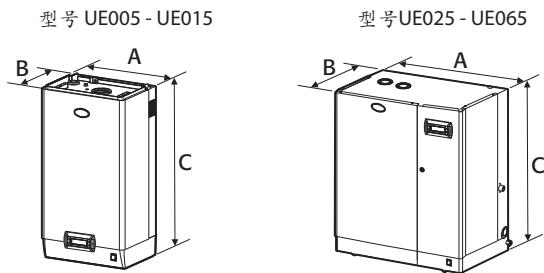
1.3 打开包装



- 确认加湿器在运输中是完好的，如发现任何因为意外或运输中的问题，请立即以书面形式知会发货方；
- 在拆开包装前将加湿器搬到安装地点，从底部抓住；
- 打开纸盒，拆开保护包装材料，移动加湿器的过程中请保持垂直；

1.4 定位

- 对于设计为墙面安装型的机组，它是足够牢靠的，能够承受正常运行条件下的重量（参考下文的墙面安装）。UE025 - UE065 型号可立在地面上；
- 为了确保蒸汽分配正确，请将加湿器定位在接近蒸汽分配器的位置；
- 确保加湿器是水平的，减少维护保养的清洁工作量。

重要提示：在运行中，金属外壳发热促使靠墙的后背部分的温度可能达到60°C (140°F)。

与墙面的距离



图1.b

1.5 墙面安装

使用卡乐提供的安装支架和螺丝套件将加湿器固定在墙上（关于尺寸，请参考图1.d）。

安装指导：

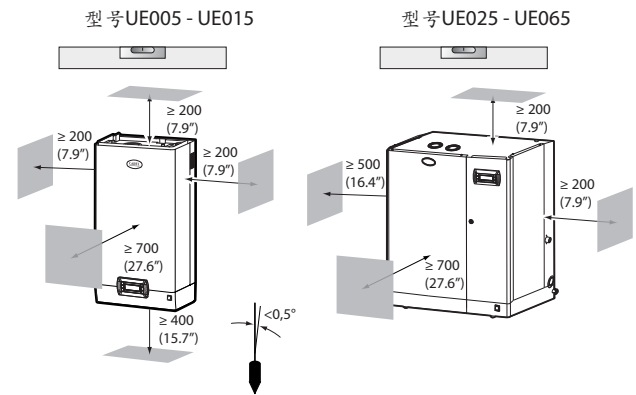
1. 将墙面安装支架从加湿器支架上卸下；
2. 扣紧墙面安装支架(参考图1.e)，用水平仪检查水平位置；如果安装在一个砖石墙上，可使用由卡乐提供的定位插销（直径8 mm/0.31"）和螺丝（直径5mm x L= 50 mm/ 0.19" x L= 1.97"）；
3. 利用设备后面顶端的槽将设备挂在支架上；
4. 通过设备背部中心的孔将设备卡牢到墙上。关于设备的重量和尺寸，请参考图1.a, 1.b, 1.c。

墙上安装孔的间距
型号UE005 - UE065



图1.c

墙上安装孔的间距
型号UE005 - UE015



型号UE025 - UE065

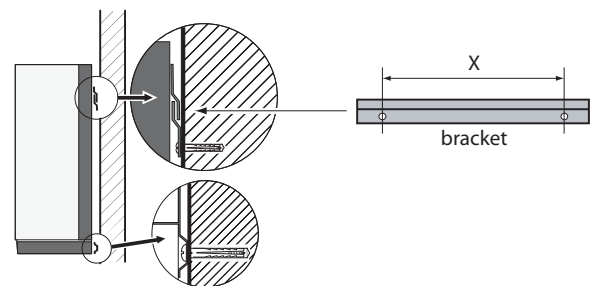
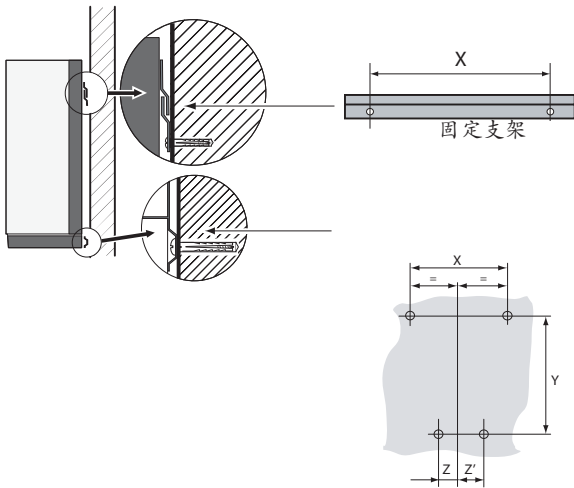

图1.d

距离 mm (")	型号			
	UE005 - UE008	UE010 - UE015	UE025 - UE045	UE065
X	270 (10.7)	270 (10.7)	445 (17.5)	535 (21.0)
Y	580 (22.8)		655 (25.8)	730 (28.7)
Z	107 (4.2)	107 (4.2)	250 (9.8)	340 (13.4)
Z'	163 (6.4)	163 (6.4)	--	--

1.6 拆下前盖板

型号UE005 - UE015:

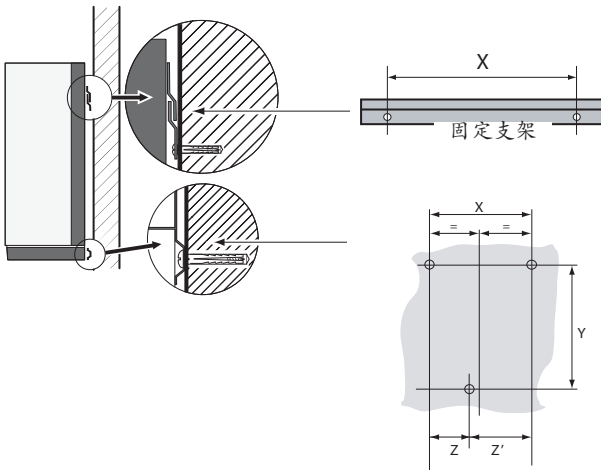

图1.e

1. 旋转椭圆形的红色Carel标识，下面露出一个螺丝；
2. 用螺丝刀拆下螺丝；
3. 从两边抓住盖板，提起大约20mm(0.79")，将盖板从加湿器凸出的边缘处松开；
4. 向前移动到底，卸下盖板；
5. 去除保护膜。

型号UE025 - UE065:

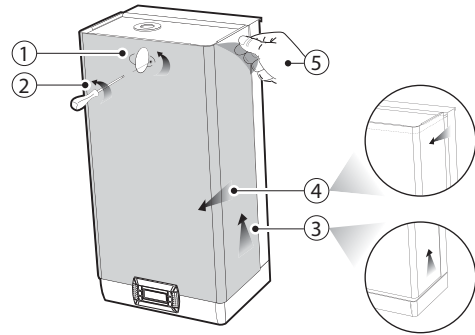

图1.f

1. 用螺丝刀从加湿器顶部拆下螺丝；
2. 从顶部抓住盖板，提起大约20 mm (0.79")；
3. 向前移动，卸下盖板；
4. 去除保护膜（加湿器全部外表面上）。

1.7 固定前盖板

型号UE005 - UE015:

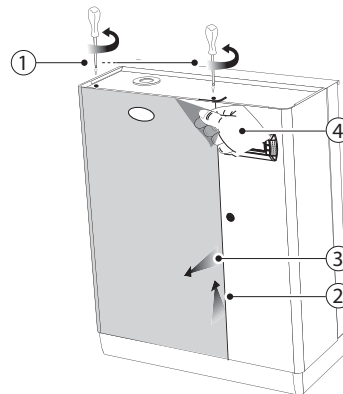

图1.g

1. 旋转椭圆形的红色Carel标识，下面露出一个紧固孔；
2. 滑动盖板到框架上（保持轻微地抬高和倾斜），直到盖板搁在背部边缘上，注意侧边的定位孔；
3. 用螺丝刀将螺丝旋紧；
4. 旋转椭圆形的红色Carel标识，直到完全盖住。

型号UE025 - UE065:

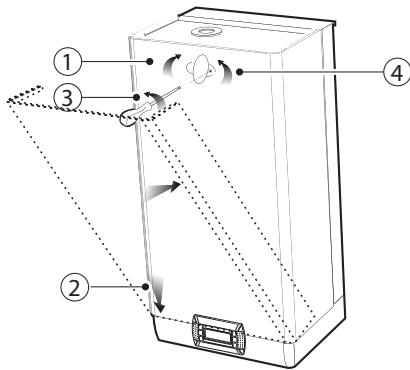

图1.h

1. 滑动盖板到框架上（保持轻微地抬高和倾斜），直到盖板搁在背部边缘上；
2. 用螺丝刀旋紧加湿器顶部的螺丝。



重要提示：对于型号为 UE025和UE065 的加湿器，用螺丝刀打开电气室门。

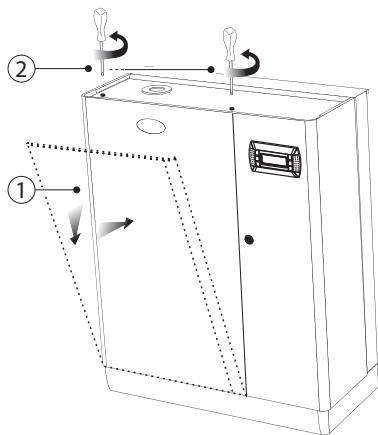

图1.i

1.8 配件和附件

打开加湿器包装并卸下加湿器前盖板后，确保以下部件都包含在内：

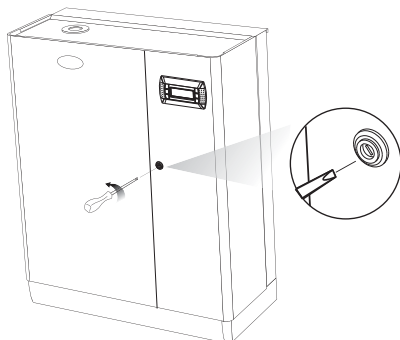

□ 用于墙面安装的膨胀螺丝



□ 用于电子控制板的连接端子组件，代码为 98C615P003



□ 仅适用于型号 UE025-UE065：代码 FWHDCV0000，带连接管的止回阀



□ 仅适用于型号UE025-UE065：塑料软管弯头（排水接口）。

2. 水路连接

重要提示：开始连接前，请切断加湿器电源。



图2.a

水路连接：

- 1. 给供水上游安装一个手动截止阀（能够切断供水）；
- 2. 将加湿器与供水连接。对于型号为UE005 - UE015 的加湿器，使用一根带3/4"接头的软管（参考参数11.2“技术规格”，与卡乐软管匹配：代码FWH3415000）。对于型号为UE025 - UE065 的加湿器，将软管与卡乐提供的止回阀连接（代码FWHDCV0000），防止加湿器内部的水进入到供水源中；
- 3. 安装一个机械过滤器，阻止固体杂质进入加湿器（连接至截止阀后端）；
- 4. 连接一段隔热的导管或软管用于排水（可抗温度100 °C (212 °F)，最小内径为40 mm/1.6")；
- 5. 准备一个漏斗，中断排水管路中的连续性；
- 6. 连接一个排水弯头以防止不好的气味回流（最小内径为40 mm/1.6")；
- 7. 对于型号为UE025 - UE065的加湿器：从加湿器底部储水仓连接一根排水软管（最小内径15 mm (0.59")）（能达到排水漏斗中）。

重要提示：当安装完成时，冲洗供水管内部大约30分钟，直接导入排水管中，而不将水供给加湿器。这将去除所有的水垢和处理的残余物，这些都可能阻塞排水泵和在沸腾时产生泡沫。

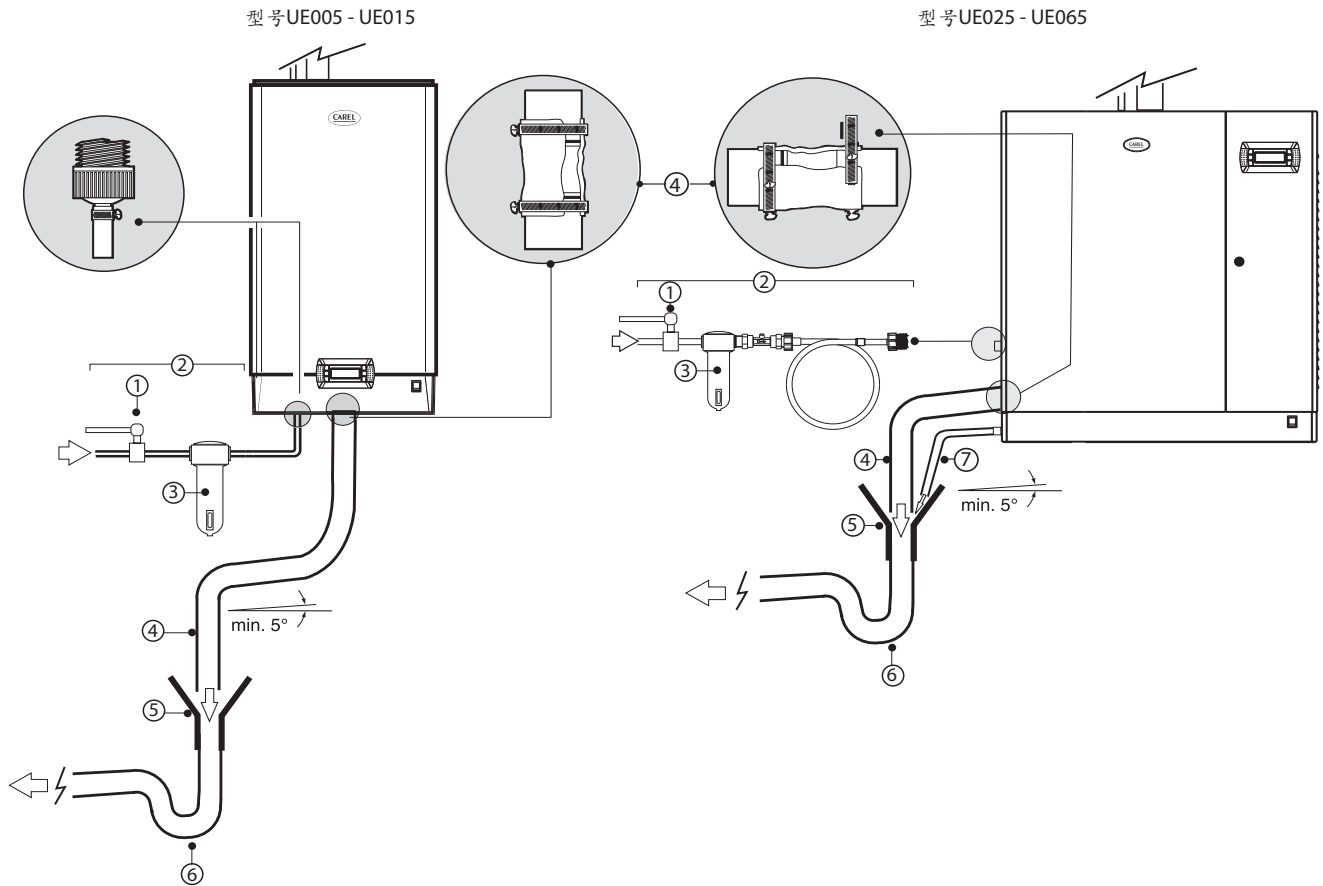
由卡乐提供的用于水路连接的接头:



图2.b

编码:

- A. 供水进口
- B. 排水出口
- C. 底部储水仓排水出口 (仅适用于型号 UE025 - UE065 的加湿器)

水路接头尺寸

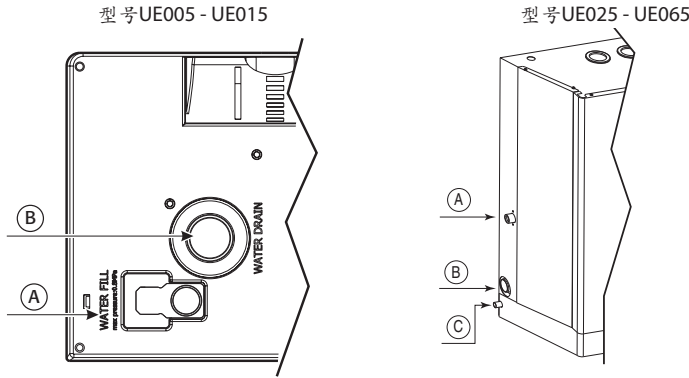
接头尺寸
排水/进水

尺寸 mm (inc)	UE005 - UE015
D	72.6 (28.6)
D'	125.4 (49.4)
E	52.6 (20.7)
E'	107.5 (42.3)

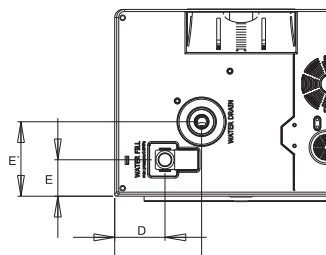

接口尺寸
蒸汽出口和冷凝排水口

尺寸 mm (inc)	UE005 - UE015
F	126.7 (50.0)
F'	224 (88.2)
G	137.9 (54.3)
G'	21.7 (8.6)

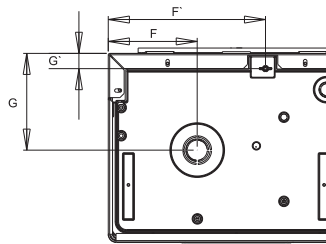

接口尺寸
排水/进水

尺寸 mm (inc)	UE025 - UE065
I	40 (15.8)
I'	72 (28.3)
I''	10.2 (4.0)
L	123.2 (48.5)
L'	231.2 (91.0)
L''	49.1 (19.3)

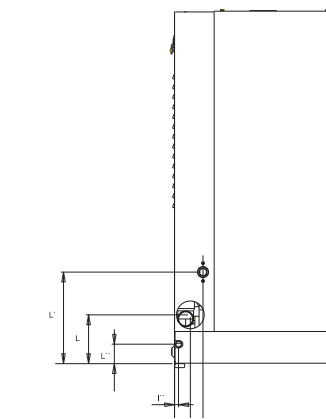

接头尺寸
蒸汽出口和冷凝排水口

尺寸 mm (inc)	UE025 - UE045	UE065
M	172 (67.7)	223.7 (88.1)
M'	30.2 (11.9)	30.2 (11.9)
N	181 (71.3)	181 (71.3)
N'	---	100 (39.4)
N''	55 (21.7)	61 (24.0)

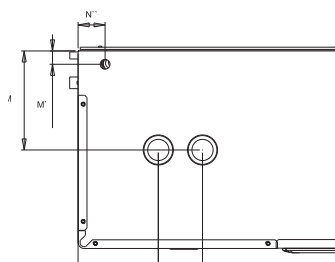

2.1 供水

仅使用自来水:

- 压力范围0.1~0.8 MPa (14.5~116 PSI), 温度范围1~40 °C (33.8 ~104 °F), 瞬时流量不低于进水电磁阀的额定流量, 连接接口为 G3/4M (参考参数“11.2 技术规格”);
- 水硬度不高于40°f (相当于的400ppm 的CaCO₃), 电导率: 75~1250 μS/cm;
- 无有机化合物。

供水特点	单位	正常供水		低含盐量的水	
		最小	最大	最小	最大
氢离子 (pH)		7	8.5	7	8.5
20°C时的特殊电导率 (σ _{R,20°C})	μS/cm	300	1250	75	350
总的未溶解的固体 (Ca)	mg/l	(1)	(1)	(1)	(1)
180°C时的残渣 (R ₁₈₀)	mg/l	(1)	(1)	(1)	(1)
总硬度 (TH)	mg/l CaCO ₃	100 (2)	400	50 (2)	150
暂时硬度	mg/l CaCO ₃	60 (3)	300	30 (3)	100
铁+镁	mg/l Fe+Mn	=	0,2	=	0,2
氯化物	ppm Cl	=	30	=	20
硅石	mg/l SiO ₂	=	20	=	20
余氯	mg/l Cl-	=	0,2	=	0,2
硫酸钙	mg/l CaSO ₄	=	100	=	60
金属杂质	mg/l	0	0	0	0
溶剂, 稀释剂, 清洁剂, 润滑剂	mg/l	0	0	0	0

表3.a

(1)= 这个值取决于电导率; 总体而言:

TDS ≤ 0,93 * σ_{R,20°C}; R₁₈₀ ≤ 0,65 * σ_{R,20°C}

(2)= 不低于200%含氯量, 单位mg/l CL

(3)= 不低于300%含氯量, 单位 mg/l CL

水硬度和传导性之间没有确实的关联。

⚠ 重要提示:

- 不要用软化剂处理水, 这可能导致雾沫, 影响机组的运行;
- 不要在水里添加消毒剂或防蚀化合物, 这些都是潜在的刺激物;
- 不要使用井水, 工业水或来自制冷回路的水, 总的来说, 不建议使用任何有潜在化学的或生物细菌污染的水。

2.2 排水

这包含了溶解在供水中的物质, 但数量很大:

- 温度可能能达到100 °C (212 °F);
- 排出的水无毒, 可排入污水系统中。

3.4 蒸汽软管

- 使用CAREL软管（最长4m，参考30页“蒸汽软管的类型”）。刚性管可能会爆裂而导致蒸汽泄漏；
- 避免存水弯的形成（产生冷凝）；
- 避免由于严重弯曲或扭曲导致的软管阻塞；
- 使用金属管箍紧固软管与加湿器和蒸汽分配器的连接口，避免因为高温而分离。
- 避免蒸发桶底部承受外来压力。

3.5 冷凝排水软管

加湿器工作期间，部分蒸汽可能会冷凝，导致效率降低，产生噪音（如汩汩声）。

要排出冷凝水，在排水软管上连接一个疏水器到加湿器底部，最小斜度为5°（参考图3.d）。卡乐冷凝排水软管代码1312353APG。

重要提示：在开启加湿器前，冷凝排水软管内的排水疏水器必须充满水。

蒸汽软管和冷凝排水软管的正确与不正确连接的事例。

最终检查

- 蒸汽输出管向上输送，分配器最小向上倾斜2°（参考图3.c）；
- 软管的末端用金属管箍夹紧；
- 管道系统中的弯道非常宽（半径300mm/11.8"），因此不会导致弯曲或阻塞；
- 蒸汽软管没有形成存水弯而导致冷凝水的形成。
- 蒸汽和冷凝软管的路径在这个章节里都有描述（参考图3.d）；
- 蒸汽软管的长度不长于4米（13.1英尺）；
- 蒸汽软管的倾斜足够允许正确的排出冷凝水（对于向上的部分 >20°，对于向下的部分 >5°）；
- 每一个点上的冷凝软管的倾斜至少为5°；
- 冷凝软管往往都是向下的路径，具有一个排水疏水器（在运行前充满水）防止放出蒸汽。

正确

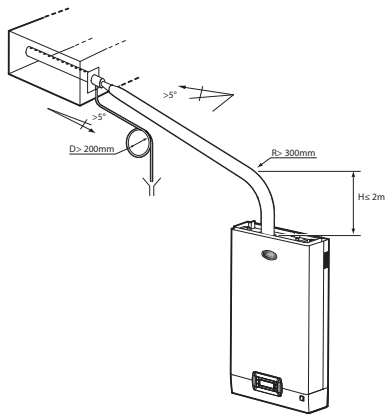

全部UE型号

正确

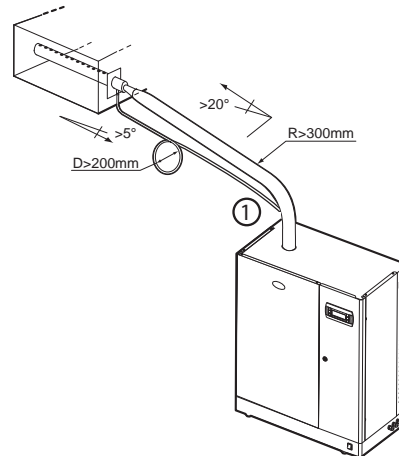

型号UE25 - UE130
(1) 延长加湿器内的软管至底部储水箱。

正确

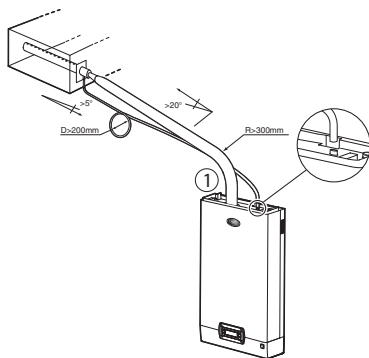

型号UE001 - UE025
(1): 与储水箱连接

错误

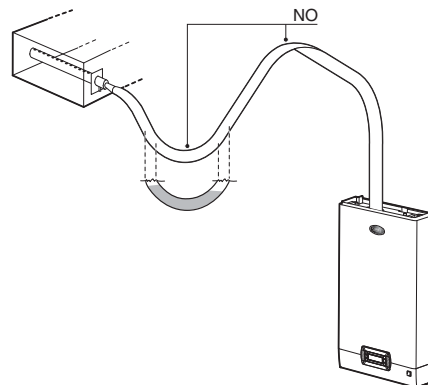

全部UE型号

4. 电气连接

4.1 准备布线



图4.a



图4.b

图4.a & 4.b编码:

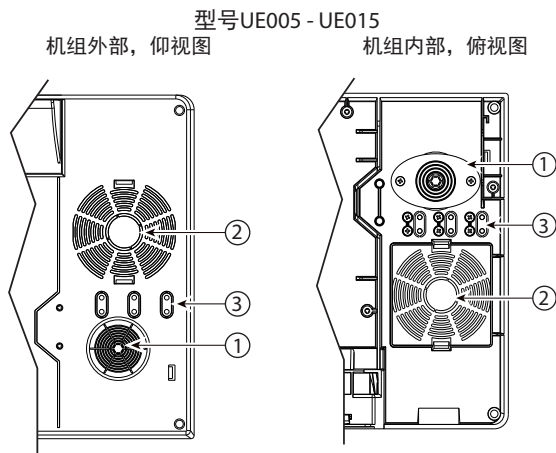
1. 电源线入口
2. 可选有效线入口 (开孔后)
3. 传感器线入口。在UE005-UE015型号的加湿器上, 撕下塑料“标签”, 用它来保护线。

4.2 电源线连接

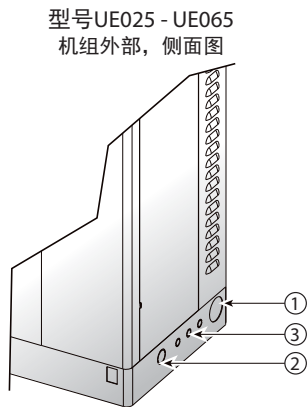
在进行接线前, 确保机器与主电源连接断开。

检查装置的电压是否符合电子控制板上铭牌标示的额定值。通过随机提供的线缆套管穿入电源线和接地线, 或通过带线缆塞的线缆套管, 将线缆末端连接到端子上 (参考图 4.c)。加湿器电源线必须由安装人员装配一个隔离开关和保护熔断器, 以防止短路。

表11.a列出了推荐的电源线的横截面和熔断器额定值: 注意, 无论如何, 该数据只是一个参考, 如果它们与当地标准不符合, 应遵守当地规范。



注意: 为了避免意想不到的干扰, 电源线须远离传感器信号线。



图4.c(机组内部, 电气室)



重要提示: 将黄线-绿线接地(GND)。

4.3 蒸汽生产控制信号 (M2.1 - M2.7)

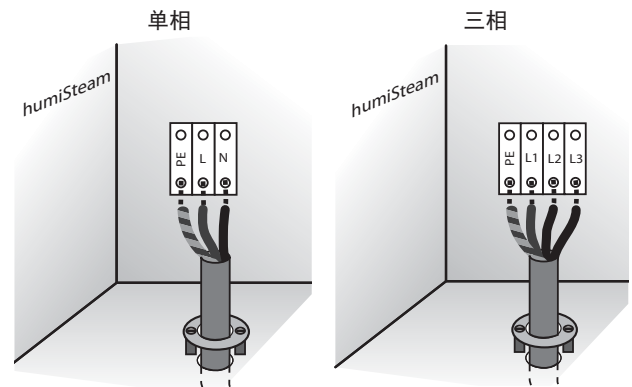
蒸汽生产和控制有不同的方式 (开关式或比例调节式), 取决于所用的信号类型。

通过关闭端子M2.4和M2.5启动蒸汽生产。

1. 启动蒸汽生产:

湿度开关 (开/关动作)

- 将输入点M2.2和M2.3(蒸汽生产请求)与一个湿度开关连接;
- 输入点M2.4和M2.5跳线 (启动);
- 设定参数A0=0 启动开/关动作。



图4.d

湿度开关和远程触点 (开/关动作)

- 连接输入点M2.2和M2.3 (蒸汽生产请求) 到一个湿度开关;
- 连接输入点M2.4和M2.5(启动)到一个远程触点 (例如: 开关, 时钟等);
- 设定参数A0=0 启动开关动作。

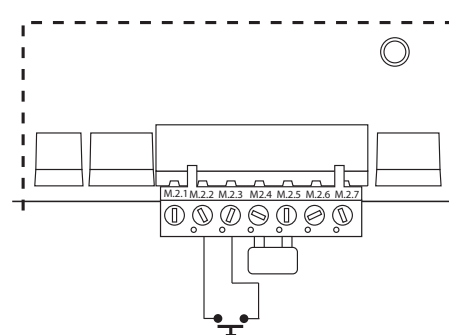

图4.e

2. 启动和控制蒸汽生产:

外部控制器比例调节 (调节动作)

- 输入点M2.4和M2.5跳线 (启动) ;
- 连接输出点M2.2和M2.3 (蒸汽生产请求) 到一个外部控制器;
- 设定参数A0=1启动调节动作 (参考章节7), 参数A2由选择的信号决定 (0~10V, 2~10V, 0~20mA, 4~20 mA) (参考章节7)。

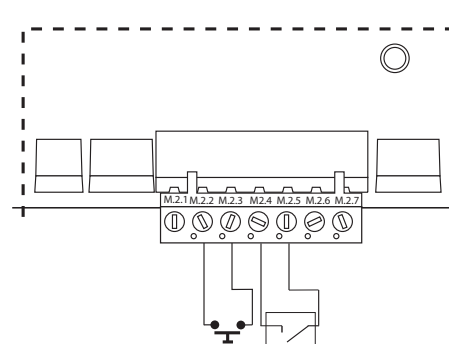

图4.f

用主传感器和远程触点控制

- 连接输入点M2.4和M2.5(启动)到一个远程触点;
- 连接主传感器到端子M2.1, M2.2和M2.3;
- 设定参数A0=2启动主传感器 (参考章节7), 参数A2由选择的信号决定 (0~10V, 2~10V, 0~20mA, 4~20 mA) (参考章节7)。

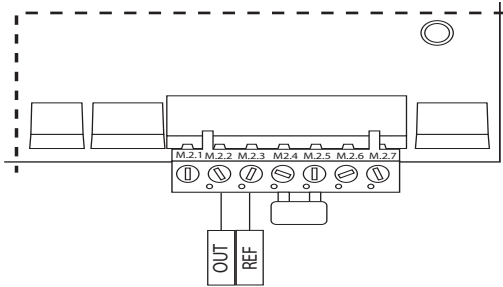

图4.i

外部控制器比例调节和远程触点 (调节动作)

- 连接输入点M2.4和M2.5(启动)到一个远程触点;
- 连接输出点M2.2和M2.3 (蒸汽生产请求) 到一个外部控制器;
- 设定参数A0=1启动调节动作 (参考章节7), 参数A2由选择的信号决定 (0-10V, 2-10V, 0..20mA, 4-20 mA) (参考章节7)。

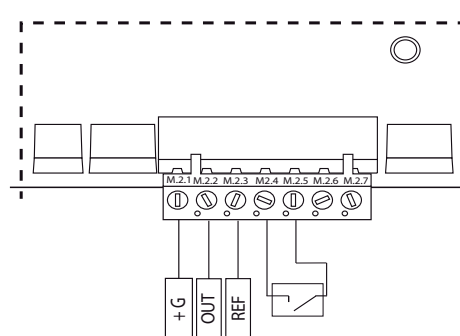

图4.g

用CAREL NTC传感器

- 输入点M2.4和M2.5跳线 (启动) ;
- 连接传感器到端子M2.2和M2.3;
- 设定参数A0=2启动传感器 (参考章节7), 参数A2=5 (NTC)。

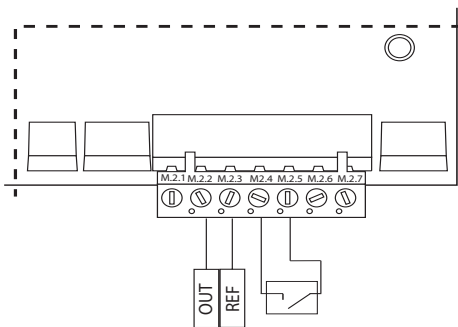

图4.j

注意: 在工业环境中(IEC EN61000-6-2), 来自机组的运行信号线的长度不得超过10 m (33 ft)⁽¹⁾: 蒸汽生产信号线(端子M2.1...M2.3), 远程开/关输入(端子M2.4...M2.5)和用于RS485通讯的屏蔽线。

用主传感器控制

- 输入点M2.4和M2.5跳线 (启动) ;
- 连接主传感器到端子M2.1, M2.2和M2.3;
- 设定参数A0=2启动主传感器 (参考章节7), 参数A2由选择的信号决定 (0~10V, 2~10V, 0~20mA, 4~20 mA) (参考章节7)。

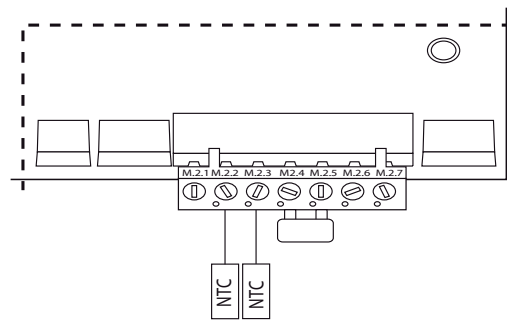

图4.h

用CAREL NTC传感器和远程触点控制

- 连接输入点M2.4和M2.5(启动)到一个远程触点;
- 连接传感器到端子M2.2和M2.3;
- 设定参数A0=2启动传感器 (参考章节7), 参数A2=5 (NTC)。

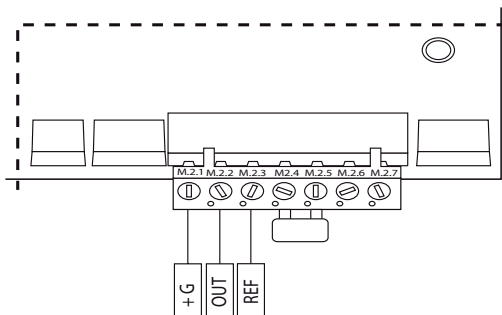

图4.k

可提供的默认CAREL传感器 (0-10V)

室内: 代码DPWC112000

风道: 代码DPDC112000和DPDC212000

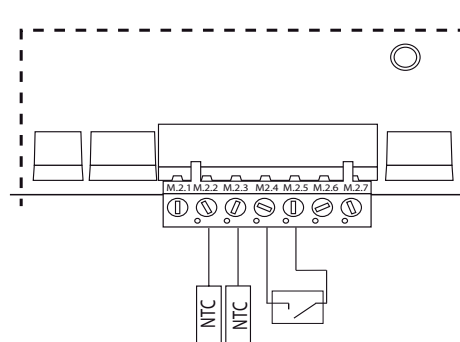
工业环境: 代码DPPC112000和DPPC212000

如果没有使用CAREL传感器，请检查：

- 电压信号0...10Vdc, 2...10Vdc, 端子M2.2 (GND: M2.3);
 - 电流信号4...20 mA, 0...20 mA, 端子M2.2 (GND: M2.3);
- 此外，由供电电源的类型决定：
- +15V, 端子M2.1。

4.4 报警触点 (M5.1 - M5.2)

可用于远程显示一个或多个报警信号的触点。



图4.h

电气规格：250Vac；最大电流：2A 阻抗，2A 感应。

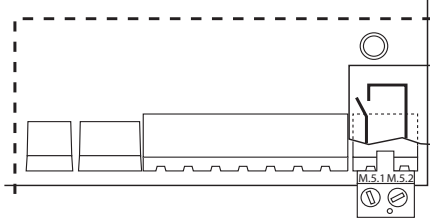

注意：在继电器端子排（报警，设备）上使用夹子以防止线脱落。

4.5 辅助触点：生产请求，外置风扇控制 (M14.1 - M14.3)

继电器触点表示蒸汽生产请求的存在。它还可以用来控制外置风扇（参考小节12.7）。

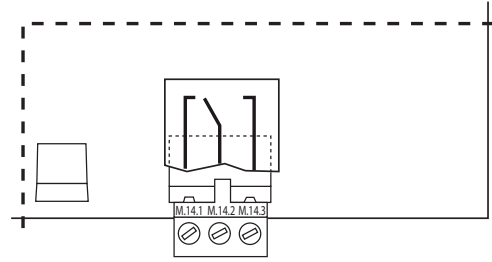

电气规格：250Vac；最大电流：8A 阻抗，2A 感应。

最终检查

以下情形代表了正确的电气连接：



- 设备额定电压与额定供电电压相符；
- 安装的熔断器适合于线路和供电电压；
- 已经安装了一个主切断开关，当需要时可用于切断加湿器的连接电源；
- 加湿器已经正确的接地；
- 电源线用附带提供的缆压盖紧固了；
- 端子M2.4和M2.5已经跳线或连接到一个启动-运行触点；
- 如果加湿器是由外部控制设备控制，信号的地线已经被连接到控制器的地线。

5. 远程终端和监控网络

5.1 远程显示终端

显示终端能与加湿器分开，放在最大可达30米（98英尺）外的地方。



图5.a

编码：

- 1 6芯电话线（最大可达10m（33英尺））；
- 2 两个EMC过滤器（代码0907858AXX）应用于电话线末端；
- 3 远程显示终端。

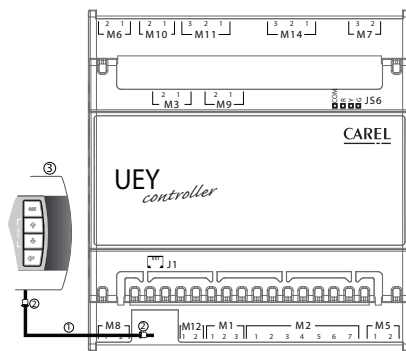

注意：要盖住加湿器上拿掉显示屏后空出的地方，可用CAREL组件，代码HCTREW0000。

⁽¹⁾ 如果长度超过10m（33ft），请使用屏蔽线，显示终端和控制器的屏蔽线都要连接到PE端。

5.2 RS485监控网络 (M1.1-M1.3)





图5.b

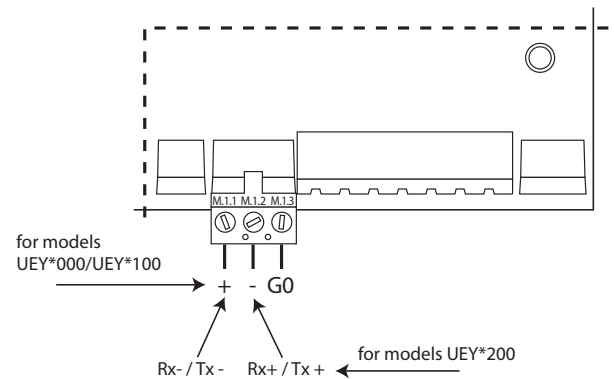

重要提示：对于家用(IEC EN 55014-1)和住宅环境(IECEN 61000-6-3)的RS485连接，使用最大长度的屏蔽电缆（显示终端和控制器的屏蔽线都要连接到PE端）：由EIA RS485协议定义的，等同于欧洲标准CCITT V11，双绞屏蔽电缆，AWG26，485 input stage impedance 1/8单位负荷（通过这种配置，最多可连接256个装置），与电源线分开放在不同的导管内。

6. 启动和用户界面

在开启加湿器前，请检查：

-  水路连接：章节2。如果有漏水，在解决问题前，请不要开启加湿器；
- 蒸汽分配：章节3和电气连接章节。

6.1 开启

- 1 
- 2 如果加湿桶是新的，按下ENTER + DOWN 键持续5秒执行一个预清洗流程。（加湿桶注满水后排空水三次，清除加湿桶内壁的杂质）。
显示屏显示图标PRE Cln

6.2 停机

- 1 排空加湿桶内的水以防止停滞（参考小节6.6 “手动排放加湿桶内的水”）。
- 2 

6.3 显示屏







图6.a

- 编码：
drain 手动排空加湿桶内的水（参考小节6.6）
-  通电（绿色LED）
-  加湿器运行中（黄色LED）
闪烁：蒸汽生产还没有处于稳定运行中
不动：蒸汽生产处于稳定运行中
报警（红色LED，无闪烁）
报警被激活：LED灯闪烁，蜂鸣器动作
如果一个报警被激活，按下ESC键使蜂鸣器噤声，则LED灯稳定不动，再次按下ESC键，复位报警（参考第8节）
- μS/cm** 电导率值
sec 时间以秒为单位
A 瞬时电流值（安培）
h 实际小时计数器
lb/hr 蒸汽流量（英制单位）
% 以额定生产能力的一个百分比生产蒸汽
kg/h 蒸汽流量（国际单位，默认）
set 参数编辑进行中（参数设置）
-  维护请求（报警激活）或纪录显示报警（HYS）
-  不动：外部风机或蒸汽生产启用；
闪烁：外部风机或蒸汽生产等待开始/停止

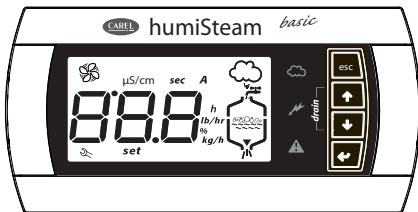
编码：

888

3位数，对于999后的值，将显示**100**，表示1000（加上小数点仅三位数字-显示第一位和第二位数字）。

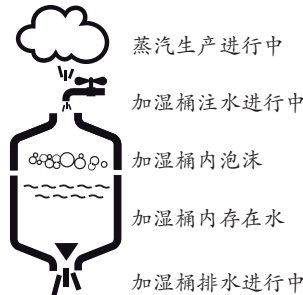

蒸汽生产进行中

加湿桶注水进行中

加湿桶内泡沫

加湿桶内存在水

加湿桶排水进行中

6.4 按键

编码	功能
Esc	返回到前一个显示界面 在主显示界面：按下持续5秒，禁用/启用加湿器
↑ UP	在主显示界面：显示湿度值（电流，电导率等等），参考下个段落 在参数列表：参数和设定值循环导航
↓ DOWN	在主显示界面：显示湿度值（电流，电导率等等） 在参数列表：参数和设定值循环导航
← ENTER (PRG)	持续2秒：进入参数列表 在参数列表：选择并确认（类似电脑键盘的“Enter”键）

6.5 主界面

加湿器上的显示屏通常显示当前的蒸汽生产（kg/h，基本显示）要显示其它值，按下UP或DOWN键，翻看下列参数：

- 电流 (A)
- 电导率 (μS/cm)
- 实际小时计数器 (h)
- 显示的输入信号

A0	A1	A2	A3	A4	A5	显示	功能
0	-	-	-	-	-	开/关	开/关
1	-	1..4	-	-	-	0..100%	外部调节器
2	-	1..4	0..100	0..100	0..100	0..100% r.H.	湿度传感器
3	0	5	0..100	0..100	0..100	0..100 °C	温度传感器
3	1	5	0..100	0..100	0..100	0..212 °F	温度传感器

表 6.c

- 设定最大蒸汽生产量（参数P0）(*)
- 加湿偏差调节（参数P1）(***)
- 出口设定值调节（参数st）(****)
- 进入报警纪录(HYS) (**)

返回到基本显示，按下ESC。

参数 C0（参考章节7）能用来改变基本显示的值（默认：当前蒸汽生产）。

(*) 要修改最大蒸汽输出(P0)，按下：

- ENTER (显示: **set**)
- UP 或 DOWN 设定蒸汽生产比例 (从20%到100%)
- ENTER键, 确认新值

按下ESC返回到主显示界面

在参数表中同样能进入参数P0 (参考章节7)。

(**) 要显示报警纪录(HYS α), 按下:

- ENTER 键(显示最近的报警)
- UP或DOWN 键, 按时间顺序滚动报警列表

按下ESC返回到主界面

要删除报警列表, 同时按下UP和DOWN持续5秒 (在报警纪录内), 当列表已经复位, 显示屏将显示“res”。

(***) 要修改加湿偏差(P1), 按下:

- ENTER (显示: **set**)
- UP 或 DOWN 修改加湿偏差值(从2到19.9)
- ENTER 键, 确认新值

按下ESC返回到主界面

在参数表中同样能进入参数P1 (参考章节7)。

(****) 要修改出口设定值(st), 按下:

- ENTER (显示: **set**)
- UP 或 DOWN修改设定值(从0到100)
- ENTER键, 确认新值

按下ESC返回到主界面

在参数表中同样能进入参数“st” (参考章节7)。

6.6 禁用

加湿器可以通过三种方式被禁用:

- 打开触点开关 M2.4和M2.5 (启用的): 显示屏显示C-
- 通过串口 (参考小节7, 开关量2): 显示屏显示S-
- 通过手操器 (参考ESC键): 显示屏显示t-

6.7 恢复工厂默认设置

恢复工厂默认设置

在主画面中, 按下ENTER键, 直到显示密码界面:

- 输入密码50
- 显示dEF信息, 闪烁

按下ENTER键, 确认或按下ESC退出

如果没有按键被按下持续30键, 显示屏将返回到主界面。

6.8 软件版本显示

1) 当启动时, 机组会显示“rel.x.y”(比如: rel.1.2)

2) 在工作时

a) 要显示: 在主界面中, 按下ESC和UP键

b) 在网络中, 通过最大为81的变量, 格式 = # # # # “(比如: 12 = release 1.2)”

6.9 开关量对应 (主板软件与连接端的对应)

humiSteam basic在启动时, 会检验控制器软件和连接端的对应。主板的第8个开关量和连接端子的第9个, 两个代码必须是对应的。上电后, 显示了软件版本后, 如果是不对应的, 正常工作时, 当按下UP+PRG, 红色LED将持续5秒钟, 将显示下列错误信息:

“X - Y”, 在这里, “X”和“Y”是两个不同的第8个开关量, 请参考售后服务。

6.10 复位小时和比率计时器

- 进入参数 ‘da’ 或 ‘db’ (参考小节7)
- 同时按下UP和DOWN持续5秒

当计时器已经复位, 显示屏将显示“res”。

6.11 参数: 保存/恢复用户设置

在主界面中, 可以在任何时候对用户设置的复制进行保存, 而后恢复。

要保存设置:

在主界面中, 按下:

- ENTER 键, 持续2秒;
- 通过UP或DOWN键, 输入密码51, 按下ENTER 键, 闪现信息UbP (用户参数备份);
- 按下ENTER 键, 闪现信息-l-;
- 按下UP或DOWN键, 闪现信息-S- (Save);
- 按下ENTER 键, 保存用户设定的复制, 或按下ESC取消操作。

注意: 之前保存的用户参数副本将被当前用户设置所覆盖。

要恢复设置:

在主界面中, 按下:

- ENTER 键, 持续2秒;
- 通过UP或DOWN键, 输入密码51, 按下ENTER 键, 闪现信息UbP (用户参数备份);
- 按下ENTER 键, 闪现信息-l-;
- 按下ENTER 键, 恢复之前保存的对用户设定的复制, 或按下ESC取消操作。

如果没有按键被按下持续30键, 显示屏将返回到主界面, 而不会完成这个操作。

6.9 手动排出加湿桶内的水

在上电时完全排水

开启加湿器, 同时按住UP和DOWN直到加湿桶和排水图标都显示出来 (显示屏上的信息‘dr’与‘tot’交替显示, 表明这个功能已经被激活)。要在完成前中止这个功能, 同时按下UP和DOWN持续5秒。

在运行中完全排水

同时按下UP和DOWN持续2秒 (显示屏上交替显示信息‘dr’和‘tot’, 表明这个功能已经被激活)。再次按下UP和DOWN持续2秒, 停止这个排水工作。排水动作可以在任何情况下自动地结束。

7. 设置参数

7.1 进入和设置参数

参数设置用来选择和控制在加湿器的状态和功能。

在主界面中按下：

- ENTER，持续2秒；
- 使用UP或DOWN输入密码77；
- ENTER，确定并进入参数列表；
- UP或DOWN，循环翻看列表；
- ENTER选择参数（显示'set'）；
- UP，修改参数值（增加）。要快速地翻看值，同时按下UP和DOWN；
- DOWN，修改参数值（减少）。要快速地翻看值，同时按下UP和DOWN；
- ENTER，保存新值并返回到参数列表，或者按下ESC不保存新值返回到列表。

按下ESC返回到主显示界面。

7.2 基本参数

参数	单位	量程	默认	备注
P0 最大蒸汽生产量（同样参考段落6.5）	%	20-100	100	
P1 加湿偏差	rH, °C	2.0, ..., 19.9	5.0	
P2 传感器最大阈值	rH, °C	0..100	80	
P3 传感器最小阈值	rH, °C	0..100	20	
st 出口设定值	%	20..100	50	
A0 工作模式 0= 开/关式控制 1= 比例式 2= 室内传感器 3= 温度传感器	-	0-3	1	
A1 测量单位 0= kg/h; 1= lb/h	-	0-1	0	
A2 蒸汽生产请求信号类型（当时A0=1，参数能被显示） 1=0-10V; 2=2-10V; 3=4-20 mA; 4=4-20 mA; 5=NTC	-	1..5	1	
A3 房间传感器最小值	rH, °C	-99..212	0	仅在“控制模式”中（A0=2）才可取得
A4 房间传感器最大值	rH, °C	0..100	0	
A5 传感器偏移量控制，适用于非CAREL传感器	rH, °C	-100..100	0	
A6 用于表示蒸汽生产请求存在的继电器M14/外部风机启用延迟	秒	0..300	0	仅当功能有效时才能看到（参数b1，参考小节11.6）
A7 用于表示蒸汽生产请求存在的继电器M14/外部风机禁用延迟	秒	0..300	180	仅当功能有效时才能看到（参数b1，参考小节11.6）
C0 通常显示地值 1= 输入/控制信号; 2= 蒸汽生产; 3= 小时计时器; 4= 电导率; 5= 电流	-	1-5	2	

7.3 高级参数

参数	单位	量程	默认	备注
b1 可选功能（参考段落11.6）	-	0-127	0	
b2 停机时的延迟时间	s	0-120	0	
b4 不考虑水电导率 0= 自动测量	µS/cm	0-1250	0	仅当功能有效时才能看到（参数b1，参考小节11.6）
b5 电导率预警阈值(*)	µS/cm	0-2000	1500	
b6 电导率报警阈值(*)	µS/cm	0-2000	2000	
b7 泡沫阈值设定 0= 监测到泡沫; 1= 监测泡沫最大灵敏度; 100= 监测泡沫最小灵敏度;	%	0-100	50	
b8 与额定值相比蒸发桶内设定的电导率稳定运行	%	50-200	100	
b9 排水时间/稀释过程	%	50-200	100	
bb 加湿桶使用后需维护的时间（小时） 0= 没有显示蒸发桶寿命报警“Cy”和维护请求报警“Mn”(*)	h	0-4000	3000	
bE 两个定期排水流程的时间（仅当定期排水流程是启用时本参数有效，b1=64）	h	1-240	24	
bf 因为不动作，排水延迟天数（如果因为不动作而排水的功能已经被禁止，本参数无效，设定参数b1=8）	days	1-199	3	

(*) 显示屏显示999后的值1000表示1000（加上小数点，仅可显示三位数-显示第一位和第二位数）。

7.4 串行连接参数









参数	单位	量程	默认	备注
C3 串行地址	-	1-199	1	
C4 波特率: 0=9,600; 1=19,200	-	0-1	1	
C5 监视器: 构成(字符位, 奇偶, 结束位) 0=8,N,2 1=8,N,1 2=8,E,2 3=8,E,1 4=8,O,2 5=8,O,1 6=7,N,2 7=7,N,1 8=7,E,2 9=7,E,1 10=7,O,2 11=7,O,1		0-11	0	
C6 连续反应传送延迟	ms	0-199	0	
C7 协议: 0= CAREL 监控器; 1= Modbus®				
C8 没有数据（发送到控制器）通过RS485，以停止蒸汽生产和产生“SU”报警的最大时间	0.1s (50=5s)	0-3000	50	参考变量“1” 62

7.5 只读参数

参数	单位	量程	默认	备注
d1 显示由外部控制器判断的信号（如果A0=1）	%	0.0-199	-	
d3 显示蒸汽生产（瞬时值）	kg/h	0.0-199	-	
d5 供水电导率(*)	µS/cm	0-1500	-	
d6 电流	A	0.0-199	-	
d7 显示最大生产量（与P0设定范围相关）	kg/h	0.0-199	-	
d9 额定蒸汽生产	kg/h	0.0-199	-	
da 加湿桶小时计数器（可重新设定）	h			
db 机组小时计数器（只读）	h			

(*) 显示屏显示999后的值1000表示1000（加上小数点，仅可显示三位数-显示第一位和第二位数）。

8. 报警

显示代码和标记	变量ID9代码	含义	原因	解决方案	复位(按键)	报警延迟启动	效果	控制板上有红色LED灯(*) (如果终端未连接)	
E0	-	1008Hex	参数校准软件验证错误	内部记忆错误	如果问题仍然存在, 联络卡乐服务中心	--	是	加湿停止	3次快闪
E1	-	1004Hex	参数设置错误	用户参数错误	如果问题仍然存在, 联络卡乐服务中心	--	是	加湿停止	4次快闪
EH	A	1010Hex	电流过大	电极上的电流过大: 可能是电极有故障或者水电导率暂时过高(尤其是当加湿器在短暂停机后开启时)	1. 检查排水泵的运行 2. 当设备未接通, 检查进水电子阀的密封性 3. 排掉一部分水然后重启	自动	是	加湿停止	2次快闪
EP		1020Hex	无蒸汽生产	蒸汽生产减少过多, 或者加湿桶完全耗尽	对加湿桶进行维护	ESC	是	加湿停止	4次慢闪
CY		3001Hex	加湿桶寿命预警	加湿桶完全使用1500个小时(默认)	对加湿桶进行维护或更换加湿桶	ESC (50小时后, 报警重新被激活)	否	仅有信号	7次快闪
EF		2004Hex	无水		检查: • 供水和进水阀; • 手动排水是否打开; • 进水电磁阀上的过滤器阻塞; • 蒸汽出口是否有过大的背压, 阻止了水流进蒸发桶; • 蒸汽出口软管未塞住或者无冷凝穴口; • 电源线被连接到加湿桶上。	自动的(等待10分钟后)	是 (等待10分钟)	仅停止加湿10分钟	3次慢闪
Ed		2008Hex	排水失败		检查排水泵和排水连接	ESC	是	加湿停止	5次慢闪
CP		3004Hex	加湿桶将要耗尽的信号		加湿桶寿命中止, 进行维修和/或更换加湿桶	ESC	否	仅有信号	6次慢闪
CL		3008Hex	加湿桶耗尽信号		加湿桶寿命中止, 进行维修和/或更换加湿桶	--	否	仅有信号	10次慢闪
EA		3002Hex	泡沫	沸腾时加湿桶内泡沫过量。泡沫的形成总体是因为水中存在表面活性剂(滑润剂, 溶剂, 清洁剂, 水处理药剂, 软化剂)或未分解的矿盐浓度过大。	1. 排掉供水管路上的水 2. 清洁加湿桶 3. 检查水里存在的软化剂(如此, 就使用其它类型的水或者减少软化)	ESC	否	仅有信号	9次慢闪
E2		3010Hex	备用存储器失败	内部存储器错误	如果问题持续, 请联络CAREL服务中心	--	否	仅有信号	6次快闪
Mn		3001Hex	加湿桶寿命中止		加湿桶工作超过2000小时的极限, 更换加湿桶	复位小时计数器	是	加湿停止	8次快闪
EU		2001Hex	加湿桶满了	当机组生产蒸汽时, 蒸发桶内水位过高	设备停机: 1. 检查进水电子阀上是否有泄漏或者冷凝回流管道; 2. 检查水位传感器是清洁的, 完全关闭管道。	--	是	仅有信号	8次慢闪

显示代码和标记	变量I89代码	含义	原因	解决方案	复位(按键)	报警延迟启动	效果	控制板上有红色LED灯(*) (如果终端未连接)	
EC	$\mu S/cm$	1002Hex	高电导率	供水电导率高	1. 检查水电导率 2. 如果问题仍然存在, 变更供水或者安装一个合适的水处理系统(去除矿物制, 甚至是部分去除)。 注意: 通过软化供水不能解决这个问题	自动	否 (b5)	仅有信号	5次快闪
						是 (b6)	加湿停止		
E3	-	2002Hex	调节信号连接失败		检查参考信号 4 - 20 mA 或 2 - 10V 或 NTC 传感器)	ESC	是	加湿停止	7次慢闪
E ₋		2020Hex	房间湿度低 (房间温度低, 当使用温度传感器)		检查传感器的工作, 和参数P2的设置范围	自动	是	加湿停止	9次快闪
E ₋		2010Hex	房间湿度低 (房间温度低, 当使用温度传感器)		检查传感器的工作, 和参数P3的设置范围	自动	是	加湿停止	10次快闪
SU		2040Hex	通讯断开			自动			2次慢闪
Pre/Cln	-		蒸发桶开始清洁信号			--	--	--	无
dr	-		启用蒸发桶排水			--	--	--	无
dr / TOT	-		因为机组不动作完全排水			--	--	--	(两个代码交替显示)
AF			防泡沫启用			--	--	--	无

表8.a

按下ESC键一次, 使蜂鸣器不发声, 再按下ESC键, 报警复位。

(*) 快闪: 亮0.2秒, 闭0.2秒

慢闪: 亮1秒, 闭1秒

9. 维护和部件

9.1 型号UE005 - UE015的加湿器部件



图9a & 9.b的编码:

- 1 进水仓
- 2 内部管道组件
- 3 进水电磁阀组件
- 4 加湿桶
- 5 带排水泵的歧管
- 6 塑料底座
- 7 塑料加湿器上盖
- 8 电流互感器 (用于测量电流的变压器)
- 9 变压器
- 10 接触器
- 11 保险丝座 F1 F2
- 12 电子控制器
- 13 电源端子
- 14 保险丝座 F3
- 15 开关
- 16 带显示屏的终端
- M 歧管

图9.a

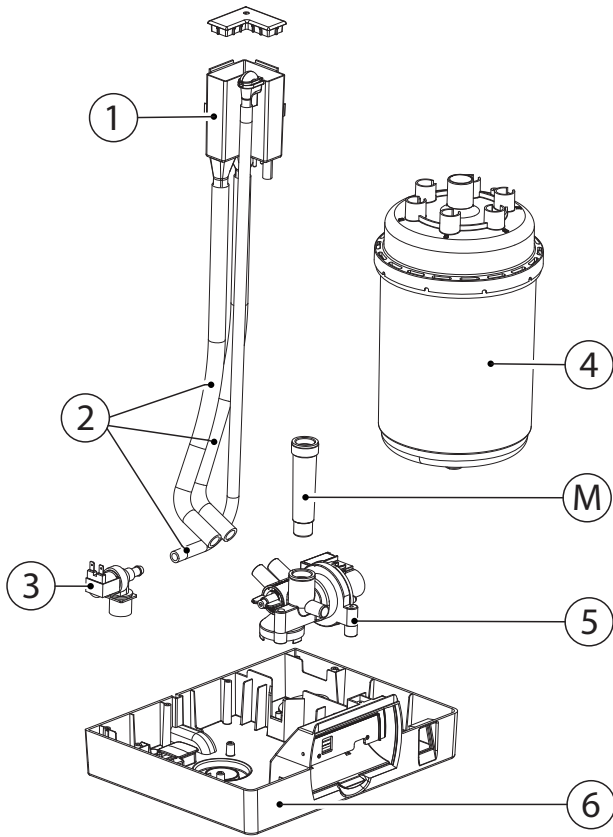

图9.b

水管路, 电气, 电子部件, UE001 - UE018 加湿器

	UE005	部件代码 UE008	UE010	UE015	位置	图
水管路						
进水仓和电导率探头		UEKVASC000			1	9.a
进水电磁阀组件	KITVC10006		KITVC10011		3	9.a
内部管道组件		UEKT10000M			2	9.a
加湿器塑料底座		UEKBOTTOM0			6	9.a
加湿器塑料顶盖		UEKTOP0000			7	9.b
组合进水/排水歧管 + 230V 泵		UEKDRAIN03			5	9.a
歧管, 用于提高加湿桶高度		UEKMANIF00			M	9.a
电气和电子部件						
显示终端		HCTLEYWCw0 ⁽³⁾			16	9.b
TAM (电流互感器)		UEKTAM0000			8	9.b
接触器	UEKCONT100		UEKCONT200		10	9.b
变压器: 230-400/24 V		UEKTR30000			9	9.b
电子控制器 ⁽¹⁾		UEYxxvCz0i ⁽²⁾			13	9.b
保险丝座 (F1, F2)		URKFH10000			11	9.b
保险丝座 (F3)		UEKFH10000			14	9.b
F1 - F2 230 ~ 400 Vac 电源保险丝		UEKFUSE100			-	参见接线图
F3 泵保险丝		UEKFUSE900			-	参见接线图
F4 变压器第二保险丝		UEKFUSE400			-	参见接线图
端子与电子控制器之间的连接线		S90CONN002			-	

Tab. 9.a

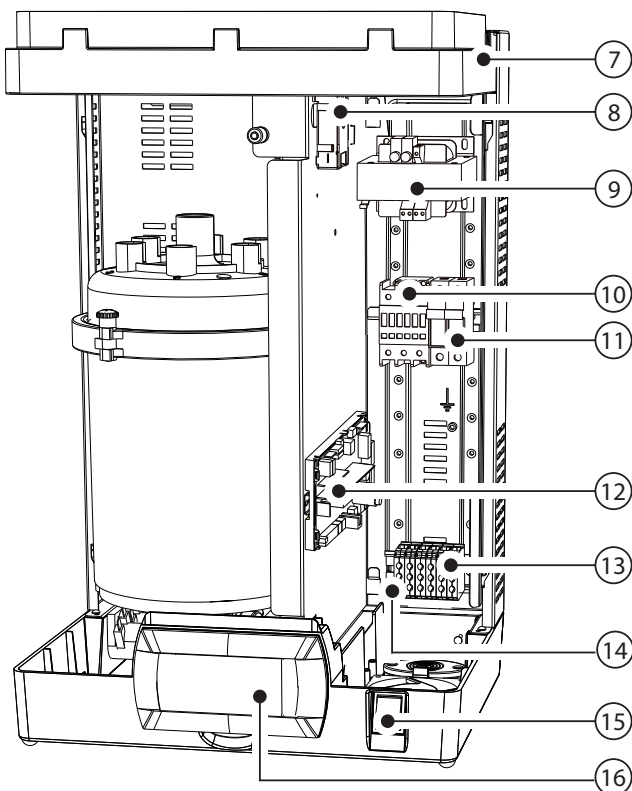
- 1) 订货时, 控制器代码在加湿器序列号和代码中都有说明。
 (2) xx: kg/h (01.....65)
 v: 电源 (D=230V 单相, L=400V 三相, 等)
 z: 对应版本号(控制器产品代码的第8位)
 i: 0 单包装 / 1 多包装
 (3) w: 对应版本号(显示终端产品代码的第9位)

部品代码表, 三相蒸发桶用于UE005 - 015加湿器, 电极和垫圈组件

类型		UE005	UE008	UE010	UE015
标准的可开启型加湿桶	400 VAC 3~, 电导率 350 - 750 μ S/cm	BLCT2C00W2	BLCT2C00W2	BLCT3C00W2	BLCT3C00W2
特殊的可开启型加湿桶	400 VAC 3~, 电导率 75 - 350 μ S/cm	BLCT2B00W2	BLCT2B00W2	BLCT3B00W2	BLCT3B00W2
	400 VAC 3~, 电导率 750 - 1250 μ S/cm	BLCT2D00W2	BLCT2D00W2	BLCT3D00W2	BLCT3D00W2
特殊的不可开启型加湿桶	400 VAC 3~, 电导率 75 - 350 μ S/cm	BL0T2B00H2	BL0T2B00H2	BL0T3B00H2	BL0T3B00H2
	400 VAC 3~, 电导率 350 - 750 μ S/cm	BL0T2C00H2	BL0T2C00H2	BL0T3C00H2	BL0T3C00H2
	400 VAC 3~, 电导率 750 - 1250 μ S/cm	BL0T2D00H2	BL0T2D00H2	BL0T3D00H2	BL0T3D00H2
电极和垫圈组件	电极组件 400 Vac 3~, 75 - 350 μ S/cm	KITBLCT2B2	KITBLCT2B2	KITBLCT3B2	KITBLCT3B2
	电极组件 400 Vac 3~, 350 - 750 μ S/cm	KITBLCT2C2	KITBLCT2C2	KITBLCT3C2	KITBLCT3C2
	电极组件 400 Vac 3~, 750 - 1250 μ S/cm	KITBLCT2D2	KITBLCT2D2	KITBLCT3D2	KITBLCT3D2
	过滤器垫圈组件	KITBLC2FG0	KITBLC2FG0	KITBLC3FG0	KITBLC3FG0

表9.c

9.2 型号UE025 - UE065的加湿器部件



图9.c

编码:

- 1 排水管路
- 2 进水电磁阀组件
- 3 内部管道组件
- 4 电导率探头
- 5 排水泵组件
- 6 歧管
- 7 排水泵软管
- 8 加湿桶
- 9 电流互感器 (用于测量电流的变压器)
- 10 变压器
- 11 接触器
- 12 泵控制继电器
- 13 保险丝座
- 14 电子控制器
- 15 电源端子
- 16 线缆夹子
- 17 开关
- 18 带液晶显示屏的终端 (安装在电气室的外壳上)

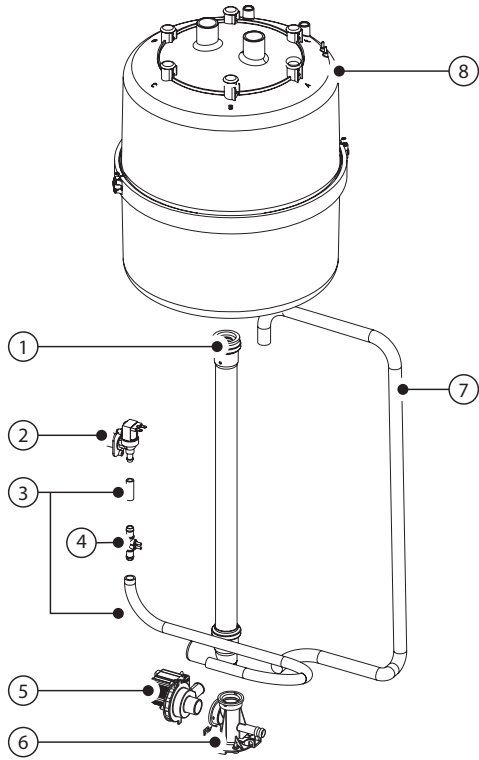

图9.d

水管路, 电气, 电子部件, UE025 - UE065 加湿器

描述	部件代码				位置	图表
	UE025	UE035	UE045	UE065		
水管路						
排水泵软管		UEKDH00000			7	9.c
上盖组件		UEKCOLL000			6	9.c
排水泵组件		KITPSE0000			5	9.c
内部管道组件		UEKT10000L		UEKT1000XL	3	9.a & 9.c
双联阀门		FWHDCV0000			-	
电导率探头		KITCN00000			4	
进水电磁阀组件		KITVC10058		KITVC10070	2	9.c
排水管路		UEKDC00000		UEKDC10000	1	9.c
电气和电子部件						
显示终端		HCTLEYWCw0 ⁽³⁾			18	9.b
TAM (电流互感器)		UEKTAM0000			9	9.b & 9.d
接触器	UEKCONT200	URKCONT400	URKCONT300		10	
变压器: 230-400/24V		UEKTR30000			11	9.b & 9.d
电子控制器 ⁽¹⁾		UEYxxvCz0l ⁽²⁾			14	9.b & 9.d
保险丝座		URKFH20000			13	9.b & 9.d
泵控制继电器		UEKRD00000			12	9.d
F1 - F2 230 - 400 Vac 保险丝	UEKFUSE100	UEKFUSE100	UEKFUSE100	UEKFUSE100	-	参考接线图
F3 泵保险丝		URKFUSE300			-	参考接线图
F4 变压器第二保险丝		URKFUSE500			-	参考接线图
端子与电子控制器之间的连接线		S90CONN002			-	

表9.d

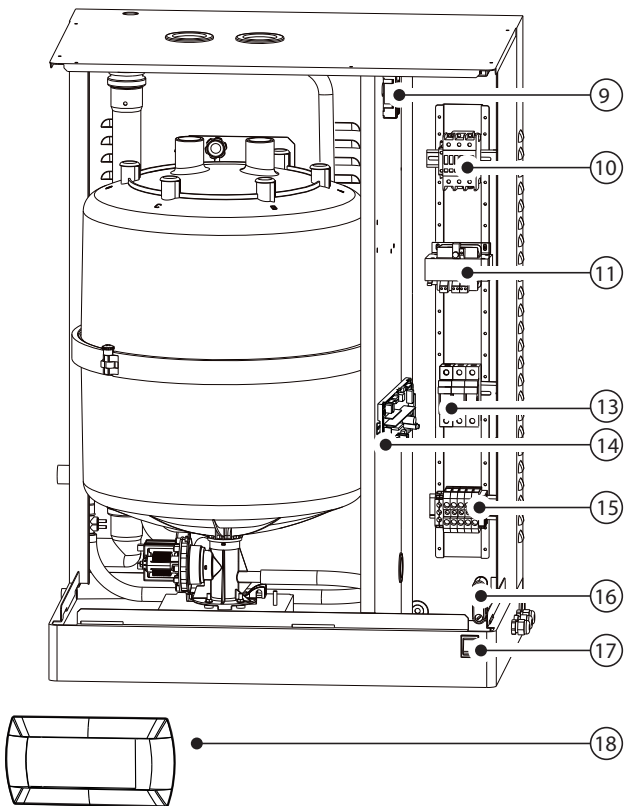
(1) 订货时, 控制器代码在加湿器序列号和代码中都有说明。

- (2) xx: kg/h (01,.....65)
v: 电源
z: 对应版本号
i: 0 表示单个包装 / 1 表示多个包装
- (3) w: 对应版本号

用于UE025 - UE065加湿器的标准的和特殊的蒸发桶部件表

类型		UE025	UE035	UE045	UE065
标准的可开启型加湿桶	400V 3ph 加湿桶, 电导率 350 - 1250 μ S/cm	BLCT4D00W2	BLCT4D00W2	BLCT4C00W2	BLCT5C00W0
特殊的可开启型加湿桶	400V 3ph 加湿桶, 电导率 75 - 350 μ S/cm	BLCT4C00W2	BLCT4C00W2	BLCT4B00W2	BLCT5B00W0
特殊的不可开启型加湿桶	400V 3ph 加湿桶, 电导率 75 - 350 μ S/cm	BLOT4C00H2	BLOT4C00H2	BLOT4B00H2	BLOT5B00H0
	400V 3ph 加湿桶, 电导率 350 - 1250 μ S/cm	BLOT4D00H2	BLOT4D00H2	BLOT4C00H2	BLOT5C00H0
电极和垫圈组件	400V 3ph 加湿桶, 电导率 75 - 350 μ S/cm	KITBLCT4C2	KITBLCT4C2	KITBLCT4B2	KITBLCT5B0
	400V 3ph 加湿桶, 电导率 350 - 1250 μ S/cm	KITBLCT4D2	KITBLCT4D2	KITBLCT4C2	KITBLCT5C0
过滤器垫圈组件		KITBLC4FG0	KITBLC4FG0	KITBLC4FG0	KITBLC5FG0

表9.e

9.3 清洁和维护加湿桶

更换



重要提示：加湿桶必须由有资质的人员进行更换，更换时加湿器的电源必须切断。

一般情况下，抛弃型的加湿桶一年后须更换（或者如果定期对加湿桶进行清洗，在加湿桶运行了2500小时后），而可开启型加湿桶则可以持续5年（或者如果定期对加湿桶进行清洗，在加湿桶运行了10000小时后）。如果有任何非正常现象发生，例如，当加湿桶内的水垢阻止了电流的正常流动它们必须立即被更换掉 - 甚至在特殊的运行中断前进行更换。

更换流程：

1. 倒掉全部的水（参考章节6）；
2. 加湿器关闭（开关拨到“0”），打开电源上的主切断开关（安全程序）；
3. 等加湿器和加湿桶冷却下来；
4. 拆下加湿器前盖
5. 拆开加湿桶上电气连接线；
6. 松开加湿桶上的锁扣装置，提起拿出加湿桶；
7. 放入新的加湿桶（确定加湿桶型号的电源与额定数据相符）；
8. 紧固加湿桶；
9. 重新连接加湿桶上的电气连接线；
10. 重新放上加湿器前盖；
11. 开启加湿器；
12. 复位加湿器小时计数器（参考章节7参数da & db）；
13. 启动清洗新加湿桶的程序，同时按下ENTER + DOWN 健5秒。

定期检查：

- 运行一年后：检查是否有明显的漏水。
 - 每15天或者运行不超过300个小时后：检查运行，是否存在明显漏水现象，外壳的总体状况。检查运行期间，电极之间是否有电弧或放电。
 - 每3个月或者运行不超过1000个小时后：
 - 抛弃型加湿桶：检查运行，是否存在明显漏水现象，如果有必要，更换加湿桶；
 - 可开启型加湿桶：如果加湿桶有明显地变黑的地方，检查电极上的沉淀物并清洁电极，使用专用的电极和垫圈组件。
 - 每1年或者运行不超过2500个小时后：
 - 抛弃型加湿桶：更换加湿桶；
 - 可开启型加湿桶：如果加湿桶有明显地变黑的地方，检查电极上的沉淀物并清洁电极，使用专用的电极和垫圈组件。
 - 5年后或者运行不超过10000个小时：更换可开启型加湿桶。
- 延长运行后，或者当使用的水富含矿盐，自然形成在电极上的固定沉淀物可能会增加，一直到加湿桶内壁。如果沉淀物是可传导的，产生的热量可能使塑料变得过热直到软化，有放出滚烫的水的风险。



重要提示：在漏水的情况下，需断开加湿器电源，因为水可能导电。

9.4 机械地排出加湿桶内的水

在未启动加湿器时，由于重力而排水，建议如果：

- 加湿器寿命中止；
- 倒空加湿桶，不开启加湿器。

机械地控制排水：

- 确保加湿器未通电；
- 拆下加湿器前盖
- 启用加湿桶下面的机械装置（参考图9.e的A部分）。

型号UE005 - UE015

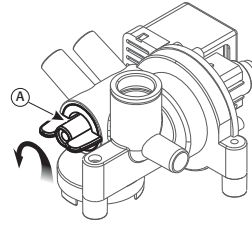

型号UE025 - UE065



图9.e

9.5 加湿桶连接，三相型UE025 - UE065

蒸汽产量 (kg/h)	电导率 (μS/cm)	电源 (V)
		400
25	75/350 μS/cm	B
	350/1250 μS/cm	B
35	75/350 μS/cm	B
	350/1250 μS/cm	B
45	75/350 μS/cm	A
	350/1250 μS/cm	B
65	75/350 μS/cm	A
	350/1250 μS/cm	B

表9.f

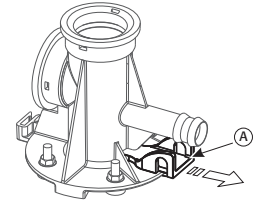
线的末端必须3牛顿·米的顶螺母紧固（仅适用于带BL*T5*加湿桶的机组）



图9.f

9.6 清洁和维护其它部件

- 当清洁塑料部件时，不要使用清洁剂或溶剂；
- 使用20%的醋酸可去掉水垢，随后与水一起冲掉。

维护检查其它的部件：

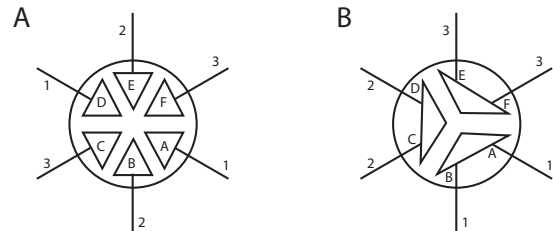
- 进水电磁阀。在断开接线和管路后，拆下电磁阀，确认进口过滤器是否清洁；如果有必要，用水或者刷子进行清洁；
- 带排水泵的上盖组件。检查加湿桶上没有附着固体沉淀物，去掉所有的混杂物。检查垫圈（O型圈）未损坏或断裂，如果有必要，更换掉。检查排水软管是否有固体沉淀物；
- 排水泵。断开电源，拆下泵并做清洁。检查储水仓是否有沉淀物，检查水是否可以自由地从储水仓中流到排水管路中（相对应的排水泵）；
- 进水仓。检查是否有堵塞或者测量到具有传导性的固定物质，电极是否清洁，去除掉混杂物并冲洗干净；
- 内部管路组件。检查管道和软管是否顺畅，是否有混杂物，如果有去除掉并冲洗干净。



重要提示：在已经更换或检查了水管路后，确认连接是紧密不漏水的。重启机组，进行一定数量的进水和排水过程（两个或四个），在这之后，实施安全程序，检查是否有任何漏水的现象。

辅助回路中的保险丝

保险丝	UE005 - 015	UE 025 - 065
F1 & F2	1 A 快速熔断，10.3x38	1 A 快速熔断，10.3x38
F3	2 A 快速熔断 5x20 陶瓷	1 A 快速熔断，10.3x38
F4	4 AT 慢速熔断，5x20 陶瓷封装	4 AT 慢速熔断，5x20 陶瓷封装

表9.g

10. 电路图

10.1 三相UE005 ~ UE015接线图

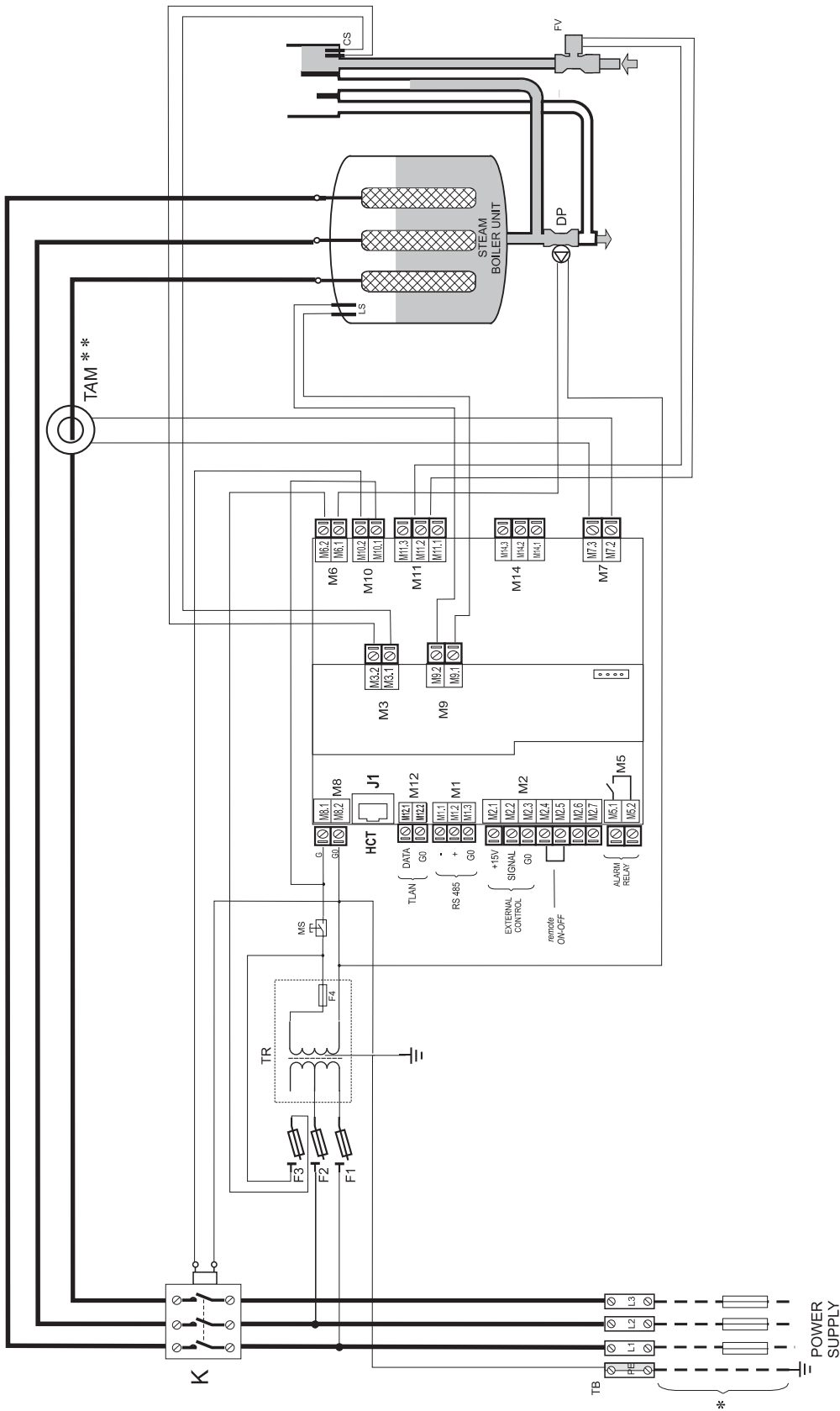

Fig. 10.a

(**) 重要：关于TAM配置和连接，请参考小节11.1

11. 总体特点和型号

11.1 humiSteam型号和电气规格

下表列出了与不同型号的加湿器的电源相关的电气规格。注意：
某些型号可能需要在不同的电压下工作，很明显输入功率和蒸汽
生产量都不同。

型号	蒸汽生产 ^(2;4) (kg/h)	功率 ⁽²⁾ (kW)	代码	电源		额定规格		电线 ⁽³⁾ (mm ²)	保险丝 ⁽³⁾ (A / type)	电路图 (图)
				电压 ⁽¹⁾ (相类型)	电流 ⁽²⁾ (A)	电流互感器配置 ⁽⁵⁾				
UE005	5.0	3.7	L	400-3~	5.4	11.a	100	1.5	10 A / 快速熔断	10.b
UE008	8.0	6.0	L	400-3~	8.7	11.a	100	2.5	16 A / 快速熔断	10.b
UE010	10.0	7.5	L	400-3~	10.8	11.d	300	2.5	16 A / 快速熔断	10.b
UE015	15.0	11.2	L	400-3~	16.2	11.a	300	6.0	32 A / 快速熔断	10.b
UE025	25	18.7	L	400-3~	27.1	11.c	500	16	50 A / 快速熔断	10.c
UE035	35	26.2	L	400-3~	37.9	11.b	500	16	60 A / 快速熔断	10.c
UE045	45	33.7	L	400-3~	48.7	11.c	700	25	80 A / 快速熔断	10.c
UE065	65	48.7	L	400-3~	70.4	11.c	700	35	100A / 快速熔断	10.c

表11.a

额定主电源的公差：-15%, +10%;

⁽²⁾ 额定值的公差+5%, -10% (EN 60335-1);

⁽³⁾ 在封闭的管道中铺设PVC的或胶线推荐值：20米长（65.6英尺）；如果有强制标准，必须依照标准；

⁽⁴⁾ 额定最大瞬时蒸汽产量：平均蒸汽生产量可能会由外部因素影响，例如：环境温度，水质量，蒸汽分配系统；

⁽⁵⁾ 要核对，参考接线图。

以上数据不是绝对的，如果有其它不同的地方标准，必须以地方标准为准。

TAM 配置和连接（用于测量电流的变压器）



重要提示：相关的配置和连接工作已由CAREL完成，无需变更。下面这些图代表了可能的连接模式，在加湿器出现某些特别严重的故障时可能有用。

所有的工作必须由有资质的人员执行，不恰当的操作可能导致设备损坏。

一根线穿过



图11.a

同一相的两根线
绕穿过一根

图11.b

同一相的两根线
绕穿过两根

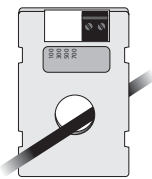
图11.c

一根线穿过两次

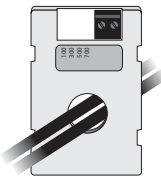

图11.d

同一相的三根线
绕穿过三根

图11.e

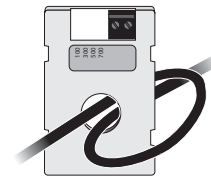

重要提示：

为避免干扰，必须将传感器的线与电源线分开。

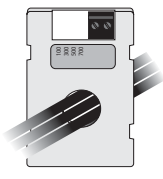
11.2 技术规格

技术规格	UEY 型号							
	UE005	UE008	UE010	UE015	UE025	UE035	UE045	UE065
蒸汽 直径mm (in)	30 (1.2)				1x40 (1x1.6)			4x40 (2x1.6)
出口压力范围 Pa (PSI)	-300到1300 (-0.131到0.188)				-900到2000 (-0.131到0.290)			
供水 接口	3/4"G							
温度范围 °C (°F)	1~40 (33.8~104)							
压力范围 (MPa)	0.1~0.8 (1~8 bar)							
水硬度范围 (°fH)	≤ 40							
瞬时流量 (l/min)	0.6		1.1		5.85 (对于 UE045 A 230Vac 型号的加湿器为7)			7
电导率范围 (µS/cm)	75~1250							
排水 接口直径 mm (in)	40 (1.6)							
典型温度 °C (°F)	≤100 (212)							
瞬时流量 (l/min)	7				22.5			
环境条件 运行环境温度 °C (°F)	1~40 (33.8~104)							
运行环境湿度 (% rH)	10~60							
储存温度 °C (°F)	-10~70 (14~158)							
储存湿度 (% rH)	5~95							
防护等级	IP20							
电子控制器 Y 型	UEY							
辅助电压/频率 (V - Hz)	24 / 50							
最大辅助电压 (VA)	90							
传感器输入 (一般都具有)	能选择以下信号 0~10 Vdc, 2~10 Vdc, 0~20 mA, 4~20 mA 输入阻抗: 20 kΩ 带: 0~10 Vdc, 2~10 Vdc 信号 100 Ω 带: 0~20 mA, 4~20 mA 信号							
启用传感器电源 (一般都 具有)	15 Vdc, 100 mA 保护以防止短路 +1 Vdc 带 135 Ω 负载							
报警继电器输出 (一般都 具有)	250 V 5 A (2 A) - 动作类型-微型开关 1C							
远程启用输入 (一般都 具有)	无源触点; 最大电阻 100 Ω; Vmax= 5 Vdc; Imax= 5 mA							
输出 瞬时蒸汽生产 ⁽¹⁾ kg/h (lb/h)	5.0 (11)	8.0 (17.6)	10.0 (22)	15.0 (33)	25 (55.1)	35 (77.2)	45 (99.2)	65 (143.3)
额定电压下的输入功率 (kW)	3.75	6.0	7.5	11.25	18.75	26.25	33.75	48.75

表11.b

*** 三相

⁽¹⁾= 平均蒸汽生产量是由以下因素影响的: 环境温度, 水质量, 蒸汽分配系统

11.3 蒸汽软管类型

代码	UEY 型号							
	UE005Y	UE008Y	UE010Y	UE015Y	UE025Y	UE035Y	UE045Y	UE065Y
蒸汽出口直径 mm (in)	30 (1.2")	30 (1.2")	30 (1.2")	30 (1.2")	40 (1.6")	40 (1.6")	40 (1.6")	2x40 (2x1.6")
最大蒸汽生产量 kg/h (lb/h)	5 (11)	8 (17.6)	10 (22)	15 (33)	25 (55.1)	35 (77.2)	45 (99.2)	65 (143.3)

CAREL 蒸汽软管									
代码	ID mm (")	UE005Y	UE008Y	UE010Y	UE015Y	UE025Y	UE035Y	UE045Y	UE065Y
1312360AXX	22 (0.9")	-	-	-	-	-	-	-	-
1312365AXX	30 (1.2")	√	√	√	√	-	-	-	-
1312367AXX	40 (1.6")	-	-	-	-	√	√	√	√

表11.c

11.4 集中喷气式蒸汽分配器型号

			UEY 型号								
代码			UE005Y	UE008Y	UE010Y	UE015Y	UE025Y	UE035Y	UE045Y	UE045Y (230V)	UE065Y
蒸汽出口直径 mm (in)			30 (1.2")	30 (1.2")	30 (1.2")	30 (1.2")	40 (1.6")	40 (1.6")	40 (1.6")	2x40 (2x1.6")	2x40 (2x1.6")
最大蒸汽生产量 kg/h (lb/h)			5 (11)	8 (17.6)	10 (22)	15 (33)	25 (55.1)	35 (77.2)	45 (99.2)	45 (99.2)	65 (143.3)

CAREL 集中式蒸汽分配器											
代码	蒸汽入口直径 mm (in)	最大蒸汽生产量 kg/h (lb/h)									
SDPOEM0022	30 (1.2")	18 (39.7)	1	1	1	1	-	-	-	-	-
SDPOEM0000	30 (1.6")	18 (39.7) (带30mm/1.6"的孔)	1	1	1	1	(2)*	(2)*	(4)**	(4)**	(4)**

表11.d

1 = 加湿器只连接一个分配器

(2) = 加湿器连接了两个分配器 (使用CAREL "Y" 组件: 代码UEKY000000)

2 = 加湿器配置了两个出口, 可以连接两个分配器

(4) = 加湿器配置了两个出口, 最多可以连接四个分配器 (使用两个CAREL "Y" 组件: 代码UEKY000000)

* = 使用CAREL "Y" 组件: 代码UEKY000000 (入口为40 mm/1.6", 出口为2 x 30 mm/1.2")

** = 使用CAREL "Y" 组件: 代码UEKY000000 (入口为40 mm/1.6", 出口为2 x 30 mm/1.2")

*** = 使用一个代码UEKY40X400的CAREL "Y" 组件(入口为40 mm/1.6", 出口为2 x 40 mm/1.6") 和两个代码为UEKY000000 的CAREL "Y" 组件(入口为40 mm/1.6", 出口为2 x 30 mm/1.2")

11.5 线性分配器型号和典型安装

				UEY 型号								
代码				UE005Y	UE008Y	UE010Y	UE015Y	UE025Y	UE035Y	UE045Y	UE045Y (230V)	UE065Y
蒸汽出口直径 mm (in)				30 (1.2")	30 (1.2")	30 (1.2")	30 (1.2")	40 (1.6")	40 (1.6")	40 (1.6")	2x40 (2x1.6")	2x40 (2x1.6")
最大蒸汽生产量 kg/h (lb/h)				5 (11)	8 (17.6)	10 (22)	15 (33)	25 (55.1)	35 (77.2)	45 (99.2)	45 (99.2)	65 (143.3)

CAREL DP型线性蒸汽分配器											
代码	蒸汽入口直径 mm (in)	最大蒸汽生产量 kg/h (lb/h)	长度 mm (in)								
DP035D30R0	30 (1.2")	5 (11)	343 (13.5)	1	-	-	-	-	-	-	-
DP045D30R0	30 (1.2")	8 (17.6)	427 (16.8)	1	1	-	-	-	-	-	-
DP060D30R0	30 (1.2")	12 (26.5)	596 (23.5)	1	1	1	-	-	-	-	-
DP085D30R0	30 (1.2")	18 (39.7)	850 (33.5)	1	1	1	(2)*	(2)*	-	-	-
DP105D30R0	30 (1.2")	18 (39.7)	1048 (41.3)	1	1	1	(2)*	(2)*	-	-	-
DP125D30R0	30 (1.2")	18 (39.7)	1245 (49)	1	1	1	(2)*	(2)*	-	-	-
DP165D30R0	30 (1.2")	18 (39.7)	1636 (64.4)	-	-	1	(2)*	(2)*	-	-	-
DP085D40R0	40 (1.6")	25 (55.1)	834 (32.8)	-	-	-	1	(2)**	(2)**	2	(4)**
DP105D40R0	40 (1.6")	35 (77.2)	1015 (40)	-	-	-	1	1	(2)**	2	2
DP125D40R0	40 (1.6")	45 (99.2)	1022 (40.2)	-	-	-	1	1	1	1**	2
DP165D40R0	40 (1.6")	45 (99.2)	1636 (64.4)	-	-	-	-	1	1	1**	2
DP205D40R0	40 (1.6")	45 (99.2)	2025 (79.7)	-	-	-	-	1	1	1**	2

表11.e

1 = 加湿器只连接一个分配器

(2) = 加湿器连接了两个分配器 (使用CAREL "Y" 组件: 代码UEKY000000)

2 = 加湿器配置了两个出口, 可以连接两个线性分配器

(4) = 加湿器配置了两个出口, 最多可以连接四个线性分配器 (使用两个CAREL "Y" 组件)

* = 使用CAREL "Y" 组件: 代码UEKY000000 (入口为40 mm/1.6", 出口为2 x 30 mm/1.2")

** = 使用CAREL "Y" 组件: 代码UEKY40X400 (入口为40 mm/1.6", 出口为2 x 40 mm/1.6")

*** = 使用两个CAREL "Y" 组件: 代码UEKY40X400 (入口为40 mm/1.6", 出口为2 x 40 mm/1.6")

关于线性蒸汽分配器的典型安装, 请参考第36页的图11.f

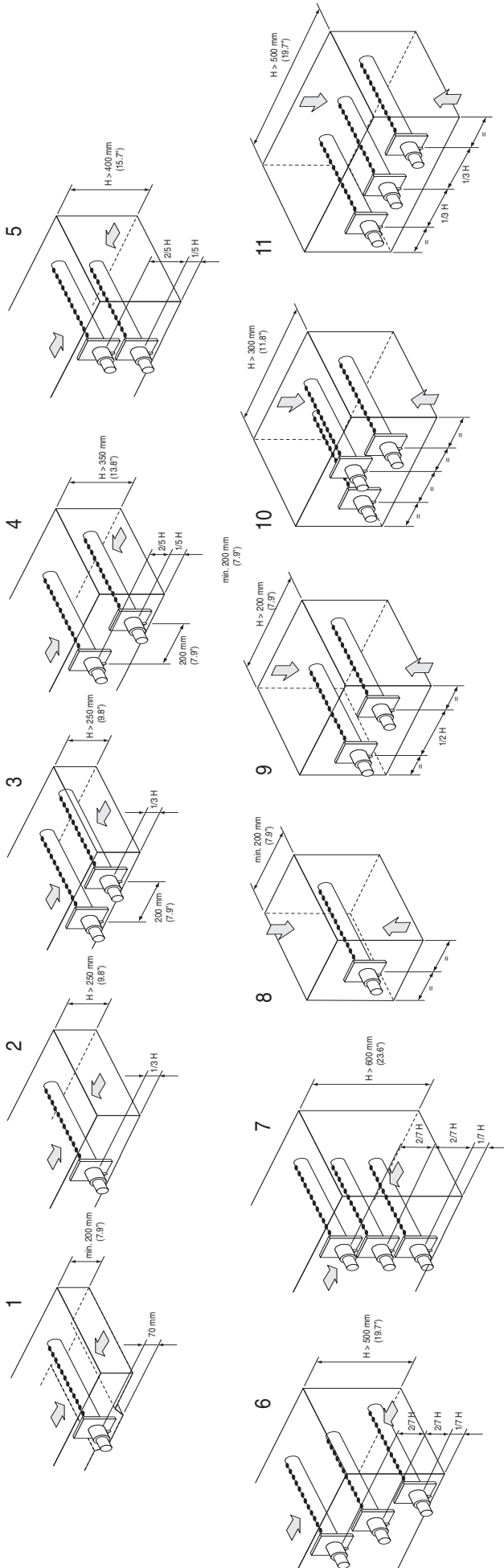

11.6 参数表b1

b1	报警继电器 振动当“CY” 报警中	稀释过程 中接触器 状态	如果新的蒸汽生产需求 ≤ 2/3 当前需求 (接触器打开)	由于加湿器不工作 而完全排水	显示“CL” &“CP” 报警	报警继电器被 激活如果:	定期完全排水	蒸汽生产信号的启用管 理/外部风机控制继电 器M14的启用管理
默认0	关	打开	是	是, 取决于参数bF	是	报警中	否	未启用
1	开	打开	是	是, 取决于参数bF	是	报警中	否	未启用
2	关	关闭	是	是, 取决于参数bF	是	报警中	否	未启用
3	开	关闭	是	是, 取决于参数bF	是	报警中	否	未启用
4	关	打开	否	是, 取决于参数bF	是	报警中	否	未启用
5	开	打开	否	是, 取决于参数bF	是	报警中	否	未启用
6	关	关闭	否	是, 取决于参数bF	是	报警中	否	未启用
7	开	关闭	否	是, 取决于参数bF	是	报警中	否	未启用
8	关	打开	是	否	是	报警中	否	未启用
9	开	打开	是	否	是	报警中	否	未启用
10	关	关闭	是	否	是	报警中	否	未启用
11	开	关闭	是	否	是	报警中	否	未启用
12	关	打开	否	否	是	报警中	否	未启用
13	开	打开	否	否	是	报警中	否	未启用
14	关	关闭	否	否	是	报警中	否	未启用
15	开	关闭	否	否	是	报警中	否	未启用
16	关	打开	是	是, 取决于参数bF	否	报警中	否	未启用
17	开	打开	是	是, 取决于参数bF	否	报警中	否	未启用
18	关	关闭	是	是, 取决于参数bF	否	报警中	否	未启用
19	开	关闭	是	是, 取决于参数bF	否	报警中	否	未启用
20	关	打开	否	是, 取决于参数bF	否	报警中	否	未启用
21	开	打开	否	是, 取决于参数bF	否	报警中	否	未启用
22	关	关闭	否	是, 取决于参数bF	否	报警中	否	未启用
23	开	关闭	否	是, 取决于参数bF	否	报警中	否	未启用
24	关	打开	是	否	否	报警中	否	未启用
25	开	打开	是	否	否	报警中	否	未启用
26	关	关闭	是	否	否	报警中	否	未启用
27	开	关闭	是	否	否	报警中	否	未启用
28	关	打开	否	否	否	报警中	否	未启用
29	开	打开	否	否	否	报警中	否	未启用
30	关	关闭	否	否	否	报警中	否	未启用
31	开	关闭	否	否	否	报警中	否	未启用
32	关	打开	是	是, 取决于参数bF	是	无报警	否	未启用
33	开	打开	是	是, 取决于参数bF	是	无报警	否	未启用
34	关	关闭	是	是, 取决于参数bF	是	无报警	否	未启用
35	开	关闭	是	是, 取决于参数bF	是	无报警	否	未启用
36	关	打开	否	是, 取决于参数bF	是	无报警	否	未启用
37	开	打开	否	是, 取决于参数bF	是	无报警	否	未启用
38	关	关闭	否	是, 取决于参数bF	是	无报警	否	未启用
39	开	关闭	否	是, 取决于参数bF	是	无报警	否	未启用
40	关	打开	是	否	是	无报警	否	未启用
41	开	打开	是	否	是	无报警	否	未启用
42	关	关闭	是	否	是	无报警	否	未启用
43	开	关闭	是	否	是	无报警	否	未启用
44	关	打开	否	否	是	无报警	否	未启用
45	开	打开	否	否	是	无报警	否	未启用
46	关	关闭	否	否	是	无报警	否	未启用
47	开	关闭	否	否	是	无报警	否	未启用
48	关	打开	是	是, 取决于参数bF	否	无报警	否	未启用
49	开	打开	是	是, 取决于参数bF	否	无报警	否	未启用
50	关	关闭	是	是, 取决于参数bF	否	无报警	否	未启用
51	开	关闭	是	是, 取决于参数bF	否	无报警	否	未启用
52	关	打开	否	是, 取决于参数bF	否	无报警	否	未启用
53	开	打开	否	是, 取决于参数bF	否	无报警	否	未启用
54	关	关闭	否	是, 取决于参数bF	否	无报警	否	未启用
55	开	关闭	否	是, 取决于参数bF	否	无报警	否	未启用
56	关	打开	是	否	否	无报警	否	未启用
57	开	打开	是	否	否	无报警	否	未启用
58	关	关闭	是	否	否	无报警	否	未启用
59	开	关闭	是	否	否	无报警	否	未启用
60	关	打开	否	否	否	无报警	否	未启用
61	开	打开	否	否	否	无报警	否	未启用
62	关	关闭	否	否	否	无报警	否	未启用
63	开	关闭	否	否	否	无报警	否	未启用
64	关	打开	是	是, 取决于参数bF	是	报警中	是, 取决于参数bE	
65	开	打开	是	是, 取决于参数bF	是	报警中	是, 取决于参数bE	
66	关	关闭	是	是, 取决于参数bF	是	报警中	是, 取决于参数bE	
67	开	关闭	是	是, 取决于参数bF	是	报警中	是, 取决于参数bE	
68	关	打开	否	是, 取决于参数bF	是	报警中	是, 取决于参数bE	
69	开	打开	否	是, 取决于参数bF	是	报警中	是, 取决于参数bE	
70	关	关闭	否	是, 取决于参数bF	是	报警中	是, 取决于参数bE	
71	开	关闭	否	是, 取决于参数bF	是	报警中	是, 取决于参数bE	
72	关	打开	是	否	是	报警中	是, 取决于参数bE	
73	开	打开	是	否	是	报警中	是, 取决于参数bE	
74	关	关闭	是	否	是	报警中	是, 取决于参数bE	
75	开	关闭	是	否	是	报警中	是, 取决于参数bE	
76	关	打开	否	否	是	报警中	是, 取决于参数bE	
77	开	打开	否	否	是	报警中	是, 取决于参数bE	

b1	报警继电器 振动当“CY” 报警中	稀释过程 中接触器 状态	如果新的蒸汽生产需求 ≤ 2/3 当前需求 (接触器打开)	由于加湿器不工作 而完全排水	显示“CL” &“CP” 报警	报警继电器被 激活如果:	定期完全排水	蒸汽产量信号的启用管 理/外部风机控制继电器 的启用管理
78	关	关闭	否	否	是	报警中	是, 取决于参数bE	未启用
79	开	关闭	否	否	是	报警中	是, 取决于参数bE	未启用
80	关	打开	是	是, 取决于参数bF	否	报警中	是, 取决于参数bE	未启用
81	开	打开	是	是, 取决于参数bF	否	报警中	是, 取决于参数bE	未启用
82	关	关闭	是	是, 取决于参数bF	否	报警中	是, 取决于参数bE	未启用
83	开	关闭	是	是, 取决于参数bF	否	报警中	是, 取决于参数bE	未启用
84	关	打开	否	是, 取决于参数bF	否	报警中	是, 取决于参数bE	未启用
85	开	打开	否	是, 取决于参数bF	否	报警中	是, 取决于参数bE	未启用
86	关	关闭	否	是, 取决于参数bF	否	报警中	是, 取决于参数bE	未启用
87	开	关闭	否	是, 取决于参数bF	否	报警中	是, 取决于参数bE	未启用
88	关	打开	是	否	否	报警中	是, 取决于参数bE	未启用
89	开	打开	是	否	否	报警中	是, 取决于参数bE	未启用
90	关	关闭	是	否	否	报警中	是, 取决于参数bE	未启用
91	开	关闭	是	否	否	报警中	是, 取决于参数bE	未启用
92	关	打开	否	否	否	报警中	是, 取决于参数bE	未启用
93	开	打开	否	否	否	报警中	是, 取决于参数bE	未启用
94	关	关闭	否	否	否	报警中	是, 取决于参数bE	未启用
95	开	关闭	否	否	否	报警中	是, 取决于参数bE	未启用
96	关	打开	是	开, 取决于参数bF	是	无报警	是, 取决于参数bE	未启用
97	开	打开	是	是, 取决于参数bF	是	无报警	是, 取决于参数bE	未启用
98	关	关闭	是	是, 取决于参数bF	是	无报警	是, 取决于参数bE	未启用
99	开	关闭	是	是, 取决于参数bF	是	无报警	是, 取决于参数bE	未启用
100	关	打开	否	是, 取决于参数bF	是	无报警	是, 取决于参数bE	未启用
101	开	打开	否	是, 取决于参数bF	是	无报警	是, 取决于参数bE	未启用
102	关	关闭	否	是, 取决于参数bF	是	无报警	是, 取决于参数bE	未启用
103	开	关闭	否	是, 取决于参数bF	是	无报警	是, 取决于参数bE	未启用
104	关	打开	是	否	是	无报警	是, 取决于参数bE	未启用
105	开	打开	是	否	是	无报警	是, 取决于参数bE	未启用
106	关	关闭	是	否	是	无报警	是, 取决于参数bE	未启用
107	开	关闭	是	否	是	无报警	是, 取决于参数bE	未启用
108	关	打开	否	否	是	无报警	是, 取决于参数bE	未启用
109	开	打开	否	否	是	无报警	是, 取决于参数bE	未启用
110	关	关闭	否	否	是	无报警	是, 取决于参数bE	未启用
111	开	关闭	否	否	是	无报警	是, 取决于参数bE	未启用
112	关	打开	是	是, 取决于参数bF	否	无报警	是, 取决于参数bE	未启用
113	开	打开	是	是, 取决于参数bF	否	无报警	是, 取决于参数bE	未启用
114	关	关闭	是	是, 取决于参数bF	否	无报警	是, 取决于参数bE	未启用
115	开	关闭	是	是, 取决于参数bF	否	无报警	是, 取决于参数bE	未启用
116	关	打开	否	是, 取决于参数bF	否	无报警	是, 取决于参数bE	未启用
117	开	打开	否	是, 取决于参数bF	否	无报警	是, 取决于参数bE	未启用
118	关	关闭	否	是, 取决于参数bF	否	无报警	是, 取决于参数bE	未启用
119	开	关闭	否	是, 取决于参数bF	否	无报警	是, 取决于参数bE	未启用
120	关	打开	是	否	否	无报警	是, 取决于参数bE	未启用
121	开	打开	是	否	否	无报警	是, 取决于参数bE	未启用
122	关	关闭	是	否	否	无报警	是, 取决于参数bE	未启用
123	开	关闭	是	否	否	无报警	是, 取决于参数bE	未启用
124	关	打开	否	否	否	无报警	是, 取决于参数bE	未启用
75	开	打开	否	否	否	无报警	是, 取决于参数bE	未启用
126	关	关闭	否	否	否	无报警	是, 取决于参数bE	未启用
127	开	关闭	否	否	否	无报警	是, 取决于参数bE	未启用

表11.f

b1	报警继电器 振动当“CY” 报警中	稀释过程 中接触器 状态	如果新的蒸汽生产需求 ≤ 2/3 当前需求 (接触器打开)	由于加湿器不工作 而完全排水	显示“CL” &“CP” 报警	报警继电器被 激活如果:	定期完全排水	蒸汽产量信号的启用管 理/外部风机控制继电 器的启用管理
128	关	打开	是	是, 取决于参数bF	是	报警中	否	启用
129	开	打开	是	是, 取决于参数bF	是	报警中	否	启用
130	关	关闭	是	是, 取决于参数bF	是	报警中	否	启用
131	开	关闭	是	是, 取决于参数bF	是	报警中	否	启用
132	关	打开	否	是, 取决于参数bF	是	报警中	否	启用
133	开	打开	否	是, 取决于参数bF	是	报警中	否	启用
134	关	关闭	否	是, 取决于参数bF	是	报警中	否	启用
135	开	关闭	否	是, 取决于参数bF	是	报警中	否	启用
136	关	打开	是	否	是	报警中	否	启用
137	开	打开	是	否	是	报警中	否	启用
138	关	关闭	是	否	是	报警中	否	启用
139	开	关闭	是	否	是	报警中	否	启用
140	关	打开	否	否	是	报警中	否	启用
141	开	打开	否	否	是	报警中	否	启用
142	关	关闭	否	否	是	报警中	否	启用
143	开	关闭	否	否	是	报警中	否	启用
144	关	打开	是	是, 取决于参数bF	否	报警中	否	启用
145	开	打开	是	是, 取决于参数bF	否	报警中	否	启用
146	关	关闭	是	是, 取决于参数bF	否	报警中	否	启用
147	开	关闭	是	是, 取决于参数bF	否	报警中	否	启用
148	关	打开	否	是, 取决于参数bF	否	报警中	否	启用
149	开	打开	否	是, 取决于参数bF	否	报警中	否	启用
150	关	关闭	否	是, 取决于参数bF	否	报警中	否	启用
151	开	关闭	否	是, 取决于参数bF	否	报警中	否	启用
152	关	打开	是	否	否	报警中	否	启用
153	开	打开	是	否	否	报警中	否	启用
154	关	关闭	是	否	否	报警中	否	启用
155	开	关闭	是	否	否	报警中	否	启用
156	关	打开	否	否	否	报警中	否	启用
157	开	打开	否	否	否	报警中	否	启用
158	关	关闭	否	否	否	报警中	否	启用
159	开	关闭	否	否	否	报警中	否	启用
160	关	打开	是	是, 取决于参数bF	是	无报警	否	启用
161	开	打开	是	是, 取决于参数bF	是	无报警	否	启用
162	关	关闭	是	是, 取决于参数bF	是	无报警	否	启用
163	开	关闭	是	是, 取决于参数bF	是	无报警	否	启用
164	关	打开	否	是, 取决于参数bF	是	无报警	否	启用
165	开	打开	否	是, 取决于参数bF	是	无报警	否	启用
166	关	关闭	否	是, 取决于参数bF	是	无报警	否	启用
167	开	关闭	否	是, 取决于参数bF	是	无报警	否	启用
168	关	打开	是	否	是	无报警	否	启用
169	开	打开	是	否	是	无报警	否	启用
170	关	关闭	是	否	是	无报警	否	启用
171	开	关闭	是	否	是	无报警	否	启用
172	关	打开	否	否	是	无报警	否	启用
173	开	打开	否	否	是	无报警	否	启用
174	关	关闭	否	否	是	无报警	否	启用
175	开	关闭	否	否	是	无报警	否	启用
176	关	打开	是	是, 取决于参数bF	否	无报警	否	启用
177	开	打开	是	是, 取决于参数bF	否	无报警	否	启用
178	关	关闭	是	是, 取决于参数bF	否	无报警	否	启用
179	开	关闭	是	是, 取决于参数bF	否	无报警	否	启用
180	关	打开	否	是, 取决于参数bF	否	无报警	否	启用
181	开	打开	否	是, 取决于参数bF	否	无报警	否	启用
182	关	关闭	否	是, 取决于参数bF	否	无报警	否	启用
183	开	关闭	否	是, 取决于参数bF	否	无报警	否	启用
184	关	打开	是	否	否	无报警	否	启用
185	开	打开	是	否	否	无报警	否	启用
186	关	关闭	是	否	否	无报警	否	启用
187	开	关闭	是	否	否	无报警	否	启用
188	关	打开	否	否	否	无报警	否	启用
189	开	打开	否	否	否	无报警	否	启用
190	关	关闭	否	否	否	无报警	否	启用

b1	报警继电器 振动当“CY” 报警中	稀释过程 中接触器 状态	如果新的蒸汽生产需求 ≤ 2/3 当前需求 (接触器打开)	由于加湿器不工作 而完全排水	显示“CL” &“CP” 报警	报警继电器被 激活如果:	定期完全排水	蒸汽产量信号的启用管 理/外部风机控制继电 器的启用管理
191	开	关闭	否	否	否	无报警	否	启用
192	关	打开	是	是, 取决于参数bF	是	报警中	是, 取决于参数bF	启用
193	开	打开	是	是, 取决于参数bF	是	报警中	是, 取决于参数bF	启用
194	关	关闭	是	是, 取决于参数bF	是	报警中	是, 取决于参数bF	启用
195	开	关闭	是	是, 取决于参数bF	是	报警中	是, 取决于参数bF	启用
196	关	打开	否	是, 取决于参数bF	是	报警中	是, 取决于参数bF	启用
197	开	打开	否	是, 取决于参数bF	是	报警中	是, 取决于参数bF	启用
198	关	关闭	否	是, 取决于参数bF	是	报警中	是, 取决于参数bF	启用
199	开	关闭	否	是, 取决于参数bF	是	报警中	是, 取决于参数bF	启用
200	关	打开	是	否	是	报警中	是, 取决于参数bF	启用
201	开	打开	是	否	是	报警中	是, 取决于参数bF	启用
202	关	关闭	是	否	是	报警中	是, 取决于参数bF	启用
203	开	关闭	是	否	是	报警中	是, 取决于参数bF	启用
204	关	打开	否	否	是	报警中	是, 取决于参数bF	启用
205	开	打开	否	否	是	报警中	是, 取决于参数bF	启用
206	关	关闭	否	否	是	报警中	是, 取决于参数bF	启用
207	开	关闭	否	否	是	报警中	是, 取决于参数bF	启用
208	关	打开	是	是, 取决于参数bF	否	报警中	是, 取决于参数bF	启用
209	开	打开	是	是, 取决于参数bF	否	报警中	是, 取决于参数bF	启用
210	关	关闭	是	是, 取决于参数bF	否	报警中	是, 取决于参数bF	启用
211	开	关闭	是	是, 取决于参数bF	否	报警中	是, 取决于参数bF	启用
212	关	打开	否	是, 取决于参数bF	否	报警中	是, 取决于参数bF	启用
213	开	打开	否	是, 取决于参数bF	否	报警中	是, 取决于参数bF	启用
214	关	关闭	否	是, 取决于参数bF	否	报警中	是, 取决于参数bF	启用
215	开	关闭	否	是, 取决于参数bF	否	报警中	是, 取决于参数bF	启用
216	关	打开	是	否	否	报警中	是, 取决于参数bF	启用
217	开	打开	是	否	否	报警中	是, 取决于参数bF	启用
218	关	关闭	是	否	否	报警中	是, 取决于参数bF	启用
219	开	关闭	是	否	否	报警中	是, 取决于参数bF	启用
220	关	打开	否	否	否	报警中	是, 取决于参数bF	启用
221	开	打开	否	否	否	报警中	是, 取决于参数bF	启用
222	关	关闭	否	否	否	报警中	是, 取决于参数bF	启用
223	开	关闭	否	否	否	报警中	是, 取决于参数bF	启用
224	关	打开	是	是, 取决于参数bF	是	无报警	是, 取决于参数bF	启用
225	开	打开	是	是, 取决于参数bF	是	无报警	是, 取决于参数bF	启用
226	关	关闭	是	是, 取决于参数bF	是	无报警	是, 取决于参数bF	启用
227	开	关闭	是	是, 取决于参数bF	是	无报警	是, 取决于参数bF	启用
228	关	打开	否	是, 取决于参数bF	是	无报警	是, 取决于参数bF	启用
229	开	打开	否	是, 取决于参数bF	是	无报警	是, 取决于参数bF	启用
230	关	关闭	否	是, 取决于参数bF	是	无报警	是, 取决于参数bF	启用
231	开	关闭	否	是, 取决于参数bF	是	无报警	是, 取决于参数bF	启用
232	关	打开	是	否	是	无报警	是, 取决于参数bF	启用
233	开	打开	是	否	是	无报警	是, 取决于参数bF	启用
234	关	关闭	是	否	是	无报警	是, 取决于参数bF	启用
235	开	关闭	是	否	是	无报警	是, 取决于参数bF	启用
236	关	打开	否	否	是	无报警	是, 取决于参数bF	启用
237	开	打开	否	否	是	无报警	是, 取决于参数bF	启用
238	关	关闭	否	否	是	无报警	是, 取决于参数bF	启用
239	开	关闭	是	否	是	无报警	是, 取决于参数bF	启用
240	关	打开	是	是, 取决于参数bF	否	无报警	是, 取决于参数bF	启用
241	开	打开	是	是, 取决于参数bF	否	无报警	是, 取决于参数bF	启用
242	关	关闭	是	是, 取决于参数bF	否	无报警	是, 取决于参数bF	启用
243	开	关闭	是	是, 取决于参数bF	否	无报警	是, 取决于参数bF	启用
244	关	打开	否	是, 取决于参数bF	否	无报警	是, 取决于参数bF	启用
245	开	打开	否	是, 取决于参数bF	否	无报警	是, 取决于参数bF	启用
246	关	关闭	否	是, 取决于参数bF	否	无报警	是, 取决于参数bF	启用
247	开	关闭	否	是, 取决于参数bF	否	无报警	是, 取决于参数bF	启用
248	关	打开	是	否	否	无报警	是, 取决于参数bF	启用
249	开	打开	是	否	否	无报警	是, 取决于参数bF	启用
250	关	关闭	是	否	否	无报警	是, 取决于参数bF	启用
251	开	关闭	是	否	否	无报警	是, 取决于参数bF	启用
252	关	打开	否	否	否	无报警	是, 取决于参数bF	启用
253	开	打开	否	否	否	无报警	是, 取决于参数bF	启用
254	关	关闭	否	否	否	无报警	是, 取决于参数bF	启用
255	开	关闭	否	否	否	无报警	是, 取决于参数bF	启用

Tab. 11.f

11.7 通过网络控制主板

下表中的变量只是所有可提供变量中的一部分。

不要设置表中没有出现的变量，否则加湿器的运行可能会受到影响。

软件版本是由四个数字组成的，在控制器后面的标签上有说明。例如：代码：“1.080”表示：硬件版本为“1.0”，软件版本为“8.0”。
确保在设定UEY控制器的地址前，已经为参数C3（内部变量为I13）设置了正确的网络地址。每个加湿器被设置为默认地址1，两个机组不能有相同的地址。

“A”		模拟变量* (Modbus®: REGISTERS)
CAREL - Modbus®		
3		参数d9: 额定生产量, 单位kg/h (参考参数表)
4		参数d7: 最大生产量, 单位kg/h (参考参数表)
15		参数d3: 瞬时蒸汽流量, 单位kg/h, 只读。格式“#### = #### (100 = 100 kg/h)”
30		参数d6: 电流(A); 只读。格式“#### = #### (16 = 16a)”
33		参数C8: 没有数据通过RS485以停止生产蒸汽和产生“SU”报警的最长时间 (参考参数表)

* 来自控制器的数据应该有一个小数点来分隔，例如：变量3=150 表示 15.0 kg/h

“I”		整型变量 (Modbus®: REGISTERS)
CAREL	Modbus®	
1	256	参数P0: 最大生产量 (参考参数表)
2	257	参数A0: 工作模式 (参考参数表)
3	258	参数A1: 测量单位 (参考参数表)
4	259	参数A2: 生产需求类型 (参考参数表)
5	260	参数b1: 其它功能 (参考参数表)
6	261	参数b2: 停机延迟时间 (参考参数表)
7	262	参数b4: 水电导率 (参考参数表)
8	263	参数b5: 电导率预报警阈值 (参考参数表)
9	264	参数b6: 电导率报警阈值 (参考参数表)
10	265	参数b7: 泡沫控制阈值 (参考参数表)
11	266	参数b8: 在稳定工作状态下与额定值相对照的加湿桶内部的电导率控制
12	267	参数C0: 被显示的额定值 (参考参数表)
13	268	参数C3: 通讯端口地址 (参考参数表)
14	269	参数C4: 波特率 (参考参数表)
15	270	参数C5: 监控器: 构成 (参考参数表)
16	271	参数C6: 通讯响应传输延迟 (参考参数表)
17	272	参数b9: 减少稀释循环中排水的持续时间 (参考参数表)
18	273	参数bb: 以小时为单位的加湿桶维护时间限值 (参考参数表)
19	274	参数bE: 两个定期排水循环之间的时间限值 (参考参数表)
20	275	参数bF: 由于机组不动作而排水的延迟天数 (参考参数表)
44	299	参数d1: 外部控制信号 参考小节“使用变量I62和I63, 控制蒸汽生产”, 只读; 格式“#### = #### (0%-100%, 幅度1%)”
46	301	加湿器状态 (只读) 0=无动作 (没有蒸汽需求, 停机或禁用); 1=开始蒸发循环; 2=进水中; 3=蒸发中; 4=防泡沫排水; 5=排水 (稀释排水或手动排水); 6=排水结束; 7=由于长期不动作而彻底排水; 8=通过手动或网络控制方式彻底排水; 9=无水管理; 10=预清洗; 11=定期排水
47	302	加湿阶段类型 (只读) 0=无动作; 1=软件启动; 2=减产方式开始稳定生产; 3=稳定生产; 4=减产方式; 5,6,7=软件启动;
49	304	参数d5: 供水电导率[μS/cm] 只读; 参考参数表
54	309	参数db: 小时计数器单位 (不能重新设定, 参考参数表)
55	310	参数dA: 加湿桶小时计数器 (可重新设定, 参考参数表)
62	317	通过RS485控制: 位0: 复位报警纪录; 位1: 复位计数器dA; 位2: 通过变量I63请求蒸汽生产; 位3: 预清洗; 位4: 复位动作的报警; 位6: 标记由于通讯未连接启用停止蒸汽生产+报警; 位7: 标记最早的报警; 位8: 标记最近的报警; 位9: 标记加载在纪录中的第一个报警; 位12: 标记以启用创建用户备份。除位2, 其它的位通过读取的值为0。在上电时, 所有的位都等于0。
63	318	通过网络请求蒸汽生产 (当I62位2=4) (0%-100%, 幅度1%)
64	319	控制板对应开关量 (只读)
67	322	参数c7 (参考参数表)
70	325	参数A5 (参考参数表)
83	338	报警状态: 位0: 存在至少一个“阻断”报警; 位1: 存在至少一个“禁用”报警; 位1: 存在至少一个“警告”报警;
84	339	报警, 同时停机 (只读), 位n=0 报警未动作; 位n=1 报警动作。参考报警表: 位0: 报警Mn; 位1: 报警EC; 位2: 报警E1; 位3: 报警E0; 位4: 报警EH; 位5: 报警EP; 位6: 没有使用; 位7: 没有使用。

85	340	报警,同时机组停用(只读),位n=0报警不动作;位n=1报警动作;参考报警表:位0:报警EU(自动复位);位1:报警E3;位2:报警EF(自动复位);位3:报警Ed;位4:没有使用;位5:没有使用;位6:没有使用;位7:没有使用。
86	341	警告(只读),位n=0:报警不动作;位n=1:报警不动作。参考报警表:位0:预报警CY;位1:报警Ec;位2:预报警EA;位3:预报警CP;位4:预报警CL;位5,位6,位7:没有使用。
89	344	在报警纪录中读取列(参考变量I62,位7-8-9)

"D"	数字变量 (Modbus®: COILS)
CAREL-Modbus®	
1	通过远程开/关禁用加湿器(端口M2.4 M2.5)只读
2	禁用控制信号: D2=1=>禁用CPY; D2=0=>CPY启用(类似远程开/关)
3	加湿器就绪,等待生产请求(只读)
4	接触器状态: 0=打开; 1=关闭(只读)
5	24Vac排水输出端的状态: 0=不排水; 1=排水(只读)
6	排水继电器输出的状态: 0=不排水; 1=排水(只读)
7	累积报警继电器: 0=未被启用; 1=被启用(只读)
8	24Vac进水输出端的状态: 0=不进水; 1=进水(只读)
10	高水位: 0=传感器未被启用; 1=传感器被启用(只读)
17	手动排水控制: 0=未被启用; 1=被启用; 如果通过网络设定为,排水将被执行,直到设置的最长时间结束,或变量'D17'被复位。
19	UEY手操器被连接: 0=不在线; 1=在线(只读)

11.8 用变量I62和I63控制蒸汽生产

- 通过网络,在启动后,立即设定D2=0(如果控制主板没有被切断,则D2不需要再次设定)。
- 设定I2=0,控制方式为开/关式(A0=0); I2=1,控制方式为比例式(A0=1)
- 设定I62=4,通过变量I63发送蒸汽生产需求。如果A0=0, I63≤50: OFF; 如果I63≥51: ON
- 将生产需求赋予变量I63,格式为000~100(0%~100%)。

注意:如果变量I62中的位6=1,当没有控制数据流通过RS485通讯连接持续的时间超过了参数C8设定的时间,蒸汽生产将停止。蒸汽生产可以重新开始,当新数据被发送时。

11.9 通过网络读取报警纪录

监视器变量I89显示保存在日志中的报警,一次一个。通常,这个变量将一直显示最近的报警的代码;要翻看保存的所有报警,设定变量I62的下面这些位:

变量I62-位7:标记请求之前的报警(只-写)

加载保存的报警,优先于在变量I89中显示当前的报警。

如果当前报警是最老的,加载的值为0。

变量I62-位8:标记请求下一个报警(只-写)

在变量I89中显示当前的报警后,立即加载保存的报警代码。

如果当前报警是最近的德(例如在已设定位0x0200以后)。值0被加载。

变量I62-位9:标记加载最后的报警到日志中(只-写)

将最近的报警代码加载到变量I89中。

日志可以保存最近的366报警。

11.10 网络通讯失败

如果网络通讯失败,UEY将打开触点,机组停机;然后UEY将转成待机状态,不生产蒸汽,报警E3将被显示。蒸汽生产可以按照下面的步骤来恢复:

- 通讯通过外部控制器恢复:UEY自动地响应来自外部控制器的请求,同时报警E3消失。
- UEY被关闭后再开启:UEY响应来自外部控制器的请求(如果通讯已经被恢复),或外部信号(0-10V,4-20mA等)发送到端口M2:1-2-3。通过这种方式,如果与外部控制器的通讯被中断,蒸汽生产可以通过UEY关闭后再开启的方式再次开始,同时利用一个外部信号0-10V(4-20mA等)发送蒸汽生产需求。

11.11 UEY控制板上的Modbus®协议

利用参数C7可以选择Modbus®协议(参考“通讯连接参数”)。

章节7列出了一系列参数及对应的地址。

对于多个读/写,“Register”或“Coil”变量的最大数量为20。

下列功能可以:

- MB_READ_COIL_STATUS 1: 用于请求一定数量“Coil”变量(二进制,1位)的状态(开或关),从特定的地址开始。不允许广播模式。
- MB_READ_INPUT_STATUS 2: 操作方式同上。
- MB_READ_HOLDING_REG 3: 用于请求“Register”变量的一个持续阻断的值(数字的,16位)。不允许广播模式。
- MB_READ_INPUT_REG 4: 操作方式同上。
- MB_FORCE_SINGLE_COIL 5: 用于设定一个单独的“Coil”变量(二进制,1位)的状态为开或关(指定涉及的位的地址)。允许广播模式。
- MB_PRESET_SINGLE_REG 6: 用于设定一个单独的“Register”变量的值(数字的,16位)。允许广播模式。
- MB_FORCE_MULTIPLE_COIL 15: 用于设定“Coil”变量一个持续阻断的值(二进制,1位)(指定位的数量和位组数)。允许广播模式。
- MB_PRESET_MULTIPLE_REG 16: 用于设定“Register”变量的一个持续阻断的值(数字的,16位)。允许广播模式。

11.12 例外管理

- 01 非法功能
- 02 非法数据地址
- 03 非法数据值

12. 高级功能

12.1 运行原理

对于电极式加湿器，通过对加湿桶内的水加热来制造蒸汽。使水达到沸点的热量是由通过加湿桶的电流产生的，使浸入加湿桶内水中的电极与外部供电电源接通。

首先，当加湿桶是新的或刚刚被清洁过的，电流的数量完全是取决于供水的类型，水中所含的矿盐越多，电流越高，蒸汽生产可以更快地达到需求。一段时间后，水中沉淀的矿盐数量会增加。（矿盐不会与水一起蒸发掉），使机组能够达到额定的蒸汽生产量。在稳定的运行条件下，所要求的蒸汽的生产是由加湿桶上的水位控制来自动地达到的。

长时间沉淀累积在加湿桶内的矿盐会损耗加湿桶。为了避免累积过度，需要定期自动地排水，然后更换一定量的新的水。

12.2 控制原理

开/关控制

控制分为或者开，或者关，由外部触点动作，然后确定控制设定点和微分。

外部触点可能是一个湿度调节器，它的状态决定加湿器的运行：

- 触点闭合：加湿器生产蒸汽，如果远程开/关触点同样闭合；
- 触点打开：蒸汽生产结束。

比例控制

蒸汽产量与来自外部设备的信号“Y”值成比例。信号类型可以在以下标准中进行选择：0-10Vdc, 2-10Vdc, 0-20 mA, 4-20 mA。整个的范围以比例段标示。最大蒸汽产量，其最大值与外部信号的最大值对应，加湿器的额定值可以在20%-100%之间进行调节（参数P0）。

最小蒸汽产量有一定的滞后，对应为外部信号“Y”比例段的5%。



图12.a

通过湿度传感器控制（参考图12.b）

蒸汽的生产与传感器的读数相关，当相对湿度值降低时，蒸汽生产增加。当相对湿度低于设定值(St)，至少等于比例段(P1)的值时，蒸汽生产达到最大。加湿器的最大蒸汽产量可以在额定值20%-100%之间进行设定（在20%-100%之间连续调节）。要为主控制传感器设定设定值和偏差：设定“SET”>设定值和比例段。最小蒸汽产量有一定的滞后，等于量程的2%。

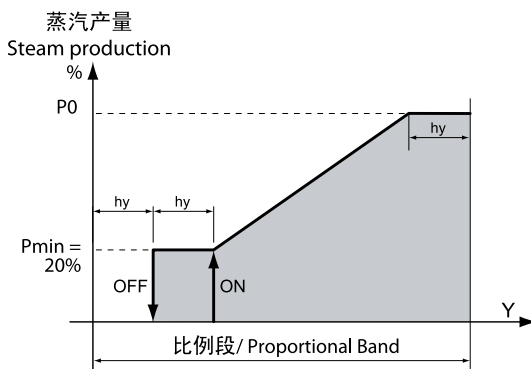

图12.b

应用于蒸汽浴室：通过温度传感器 (NTC)自动控制，参数A0=2且A2=5

对于加湿器应用于蒸汽浴室，控制传感器测量温度胜于湿度，在湿度控制章节中描述的需要考虑的内容同样有效，只需要将相对湿度换成温度。

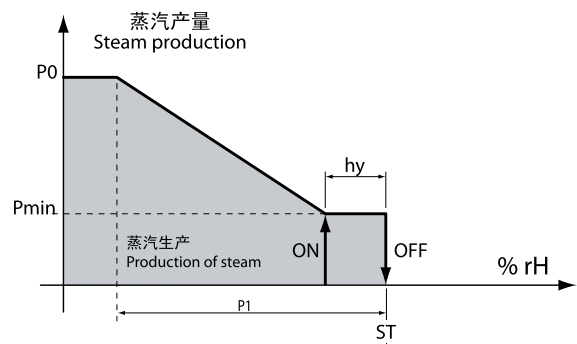

图12.c

12.3 供水电导率

电导率测量和报警

供水的电导率是当电磁阀打开时由电导率探头测量的。

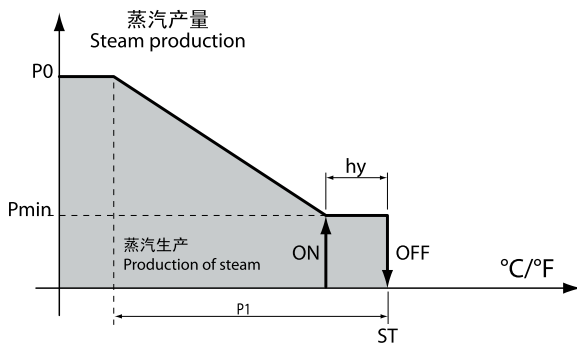
可用的两个可编辑的报警阈值是：

- b5：警告阈值（只有在没有启用报警继电器显示信号，当这个状况不再存在时自动复位）；
- b6：报警阈值（直到报警继电器启用才停止）。

当读数超过两个阈值中的一个持续60秒时，报警启用，或者如果读数高于阈值的三倍即时立即替换。

要禁用报警信号，简单地将阈值设定为高于读取的最大值即可。

12.4 自动排水

加湿器自动地排水，并且更换加湿桶内的部分水，以防止在后面的蒸发过程中产生过高矿盐浓度。

排水泵打开持续一定的时间，不管电导率是否超过了最大极限，这种情况是间接地由估计的蒸发速度来测量的。

在自动排水阶段，电极不通电，防止排水带走电流（显示屏显示“dr”）。

因为泡沫过多而排水

加湿器使用确定的几种水，在蒸汽生产中，泡沫在水上方可能形成。这个问题必须解决，因为这可能导致水与蒸汽一起释放。为此，两个电极都放置在加湿桶上方。当这些电极监测到泡沫的存在时，加湿器会启动一系列的排水过程。如果问题持续存在，加湿桶完全清洗将被启动。

因为加湿器不动作而排水

加湿器不会一直工作（加湿器可能开着但不生产蒸汽），加湿桶内的水将自动被排出，防止水停滞和卫生风险。不动作的时间是通过参数“bF”设定（默认值为3天）。这个功能可被禁用，通过设定参数b1（参考段落11.6）。

强制排水

因为矿盐过量，加湿器进行自动排水，此时电极不通电，蒸汽生产减少。在进行排水过程时要使电极保持上电，设定参数b1（参考段落11.6）。

因为蒸汽需求显著减少而排水

在蒸汽生产需求显著减少的情况下，加湿器不会等水位下降（从而减少蒸汽生产）由于它自身对蒸汽生产的影响，而执行自动排水。蒸汽生产的减少是显著的如果电流高于相关需求水平的33%。通过设定参数b1（参考段落11.6）可以禁用这个功能。

定期排水

当使用的水富含很多物质，例如腐殖质，水垢，就必须为加湿桶设定一个定期排水过程，以防止累积残渣。

要启用定期排水，设定参数b1=64。这样，每24小时后，加湿器将排出加湿桶内的全部水，显示屏将显示“dP”（定期排水）。如果定期排水是启用的，两个定期排水之间的小时数可通过参数“bE”来设定。

注意：关于手动排水功能，请参考章节6，关于机械排水，请参考段落9.4。

12.5 供水不足自动管理

不管是否有供水或者供水的流量太低，加湿器都会通过控制在打开电磁阀后电极上的电流是否增加进行检查。

这种情况下，加湿器：

- 显示报警“EF”；
- 启用报警继电器；
- 打开触点，关闭电磁阀十分钟。

十分钟后，进水电磁阀打开，触点闭合，测量相电流：如果增加，报警不动作，否则这个程序将被重复。

注意：报警是自动重启，并且根据以上描述的程序被控制的。

12.6 报警继电器开关

一旦加湿桶运行小时与加湿桶要求维护的相符（“CY”报警），报警继电器（如果没有其它报警动作）每12小时将打开持续10秒钟，直到“Mn”报警。

通过设定参数b1（参考段落11.6）可以禁用这个功能；通常这个功能是禁用的。

12.7 辅助触点管理（风机）

辅助触点可被用于：

- 远程发送信号表示蒸汽生产请求（但不是实际的值）；
- 一个外部风扇装置的启用/禁用，根据是否存在蒸汽生产请求。

通过参数b1启用这个功能，在蒸汽生产期间，如果这个触点是启用的（闭合），则有一个参数A6表示的秒数延迟，这个触点被禁用（打开）时，则有一个参数A7表示的秒数延迟。

在参数A6和A7表示的秒数时间内，这个图标（风机）将在显示屏上闪烁，而当启用时，这个图标（风机）将处于静止不动状态。

在手动排水期间（参考小节6.12），触点将被禁用（一直到参数A7表示的秒数延迟之后）。

在预清洗期间（参考小节6.1），触点将被启用，也有相对应的延迟。

12.8 手动程序

这个程序用于手动控制加湿器上的仪器。

在主界面中，按下PRG按钮持续2秒。

通过UP或DOWN按钮，输入密码70。

显示屏将显示**MAN**

按下PRG按钮。

显示屏将显示**tlr**

然后通过UP或DOWN按钮，滚动翻看不同的仪器：

- **tlr** = 接触器
- **drn** = 排水泵
- **FiL** = 进水电磁阀
- **drt** = 排水调节电磁阀SV（未使用）
- **ALr** = 报警继电器
- **FAn** = 辅助触点（风机）

从任何这些选配件中按下PRG按钮，显示：

- ON 如果这些仪器当前是启用的
- OFF 如果这些仪器当前未启用的

按下PRG按钮；显示屏开始闪烁

按下UP或DOWN按钮，修改值

按下PRG按钮，确认新值

按下ESC按钮，返回到前一个显示界面。

注意：这个模式只能在MAN显示界面下使用ESC按钮退出，或通过关闭加湿器来退出。

12.9 控制板上的LED灯

扩展板上配置了三个LED灯，位于控制板的上方：



图12.b

编码：

控制板上的LED	显示屏上的符号	含义
红色		报警中（报警类型能根据灯闪的类型来识别，参考章节8）
黄色		蒸汽生产中（当以100%生产量进行生产时LED灯一直亮着，以20%生产量进行生产时LED灯闪两次，以30%生产量进行生产时LED灯闪三次，依次类推）
绿色		加湿器已开启

表12.a

注意：黄色和红色灯仅当显示屏断开连接时才是有效的。

WARNINGS

The CAREL humidifiers are advanced products, whose operation is specified in the technical documentation supplied with the product or can be downloaded, even prior to purchase, from the website www.carel.com. Each CAREL product, in relation to its advanced level of technology, requires setup/configuration/programming/commissioning to be able to operate in the best possible way for the specific application. The failure to complete such operations, which are required/indicated in the user manual, may cause the final product to malfunction; CAREL accepts no liability in such cases.

The customer (manufacturer, developer or installer of the final equipment) accepts all liability and risk relating to the configuration of the product in order to reach the expected results in relation to the specific final installation and/or equipment. CAREL may, based on prior agreements, act as a consultant for the installation/commissioning/use of the unit, however in no case does it accept liability for the correct operation of the humidifier and the final installation if the warnings or suggestions provided in this manual or in other product technical documents are not heeded. In addition to observing the above warnings and suggestions, the following warnings must be heeded for the correct use of the product:

- **DANGER OF ELECTRIC SHOCK**

The humidifier contains live electrical components. Disconnect the mains power supply before accessing inside parts or during maintenance and installation.

- **DANGER OF WATER LEAKS**

The humidifier automatically and constantly fills/drains certain quantities of water. Malfunctions in the connections or in the humidifier may cause leaks.

- **DANGER OF BURNS**

The humidifier contains high temperature components and delivers steam at 100°C/ 212°F.

**Important:**

- The installation of the product must include an earth connection, using the special yellow-green terminal available in the humidifier.
- The environmental and power supply conditions must conform to the values specified on the product rating labels.
- The product is designed exclusively to humidify rooms either directly or through distribution systems (ducts).
- Only qualified personnel who are aware of the necessary precautions and able to perform the required operations correctly may install, operate or carry out technical service on the product.
- Only water with the characteristics indicated in this manual must be used for steam production.
- All operations on the product must be carried out according to the instructions provided in this manual and on the labels applied to the product. Any uses or modifications that are not authorised by the manufacturer are considered improper. CAREL declines all liability for any such unauthorised use.
- Do not attempt to open the humidifier in ways other than those specified in the manual.
- Observe the standards in force in the place where the humidifier is installed.
- Keep the humidifier out of the reach of children and animals.
- Do not install and use the product near objects that may be damaged when in contact with water (or condensate). CAREL declines all liability for direct or indirect damage following water leaks from the humidifier.
- Do not use corrosive chemicals, solvents or aggressive detergents to clean the inside and outside parts of the humidifier, unless specifically indicated in the user manual.
- Do not drop, hit or shake the humidifier, as the inside parts and the linings may be irreparably damaged.

CAREL adopts a policy of continual development. Consequently, CAREL reserves the right to make changes and improvements to any product described in this document without prior warning. The technical specifications shown in the manual may be changed without prior warning.

The liability of CAREL in relation to its products is specified in the CAREL general contract conditions, available on the website www.carel.com and/or by specific agreements with customers; specifically, to the extent where allowed by applicable legislation, in no case will CAREL, its employees or subsidiaries be liable for any lost earnings or sales, losses of data and information, costs of replacement goods or services, damage to things or people, downtime or any direct, indirect, incidental, actual, punitive, exemplary, special or consequential damage of any kind whatsoever, whether contractual, extra-contractual or due to negligence, or any other liabilities deriving from the installation, use or impossibility to use the product, even if CAREL or its subsidiaries are warned of the possibility of such damage.

DISPOSAL

The humidifier is made up of metal parts and plastic parts. In reference to European Union directive 2002/96/EC issued on 27 January 2003 and the related national legislation, please note that:

1. WEEE cannot be disposed of as municipal waste and such waste must be collected and disposed of separately;
2. the public or private waste collection systems defined by local legislation must be used. In addition, the equipment can be returned to the distributor at the end of its working life when buying new equipment;
3. the equipment may contain hazardous substances: the improper use or incorrect disposal of such may have negative effects on human health and on the environment;
4. the symbol (crossed-out wheeled bin) shown on the product or on the packaging and on the instruction sheet indicates that the equipment has been introduced onto the market after 13 August 2005 and that it must be disposed of separately;
5. in the event of illegal disposal of electrical and electronic waste, the penalties are specified by local waste disposal legislation.

Warranty on the materials: 2 years (from the date of production, excluding consumables).

Approval: the quality and safety of CAREL products are guaranteed by the ISO 9001 certified design and production system, as well as by the  mark.

Content

1. INTRODUCTION AND ASSEMBLY	7		
1.1 humiSteam (UEY*)	7		
1.2 Dimensions and weights	7		
1.3 Opening the packaging	7		
1.4 Positioning	7		
1.5 Wall-mounting	7		
1.6 Removing the front cover	8		
1.7 Fitting the front cover	9		
1.8 Components and accessories	9		
2. WATER CONNECTIONS	10		
2.1 Supply water	11		
2.2 Drain water	11		
3. STEAM DISTRIBUTION	12		
3.1 CAREL jet distributors (SDPOEM00**)	12		
3.2 CAREL linear distributors for air ducts (DP***DR0)	12		
3.3 CAREL steam blowers (VSDU0A*, models UE003 to UE015 only)	12		
3.4 Steam hoses	13		
3.5 Condensate drain hose	13		
4. ELECTRICAL CONNECTIONS	14		
4.1 Preparing the electric cableways	14		
4.2 Power cable connection	14		
4.3 Steam production control signals (M2.1 - M2.7)	14		
4.4 Alarm contact (M5.1 - M5.2)	16		
4.5 Auxiliary contact: prod. request present, external fan control) (M14.1 - M14.3)	16		
5. REMOTE TERMINAL AND SUPERVISORY NETWORK	16		
5.1 Remote display terminal	16		
5.2 RS485 supervisory network (M1.1-M1.3)	16		
6. STARTING AND USER INTERFACE	17		
6.1 Starting	17		
6.2 Stopping	17		
6.3 Display	17		
6.4 Keypad	17		
6.5 Main display	17		
6.6 Disabling	18		
6.7 Recalling the manufacturer defaults	18		
6.8 Display software release	18		
6.9 Match digit (match between the softwares of board and terminal)	18		
6.10 Reset cylinder hour counters	18		
6.11 Parameters: Saving/recalling the user settings	18		
6.12 Manually drain the water in the cylinder	18		
7. CONFIGURATION PARAMETERS	19		
7.1 Accessing and setting the parameters	19		
7.2 Basic parameters	19		
7.3 Advanced parameters	19		
7.4 Serial connection parameters	19		
7.5 Read-only parameters	19		
8. ALARMS	20		
		9. MAINTENANCE AND SPARE PART	22
		9.1 Spare parts for models UE005 to UE015	22
		9.2 Spare parts for models UE025 to UE065	24
		9.3 Cleaning and maintenance of the cylinder	25
		9.4 Mechanically draining the water in the cylinder	26
		9.5 Cylinder connection, three-phase models UE025 to UE065	26
		9.6 Cleaning and maintenance of the other components	26
		10. WIRING DIAGRAMS	27
		10.1 Diagram of three-phase models UE005 to UE015	27
		10.2 Diagram of three-phase models UE025 to UE065	28
		11. GENERAL FEATURES AND MODELS	29
		11.1 humiSteam models and electrical specifications	29
		11.2 Technical specifications	30
		11.3 Models of steam hoses	30
		11.4 Models of concentrated jet steam distributors	31
		11.5 Models of linear distributors and typical installations	31
		11.6 Table of parameter b1	33
		11.7 Controlling the board via network	36
		11.8 Controlling production using variables I62 and I63	37
		11.9 Read alarm log via the network	37
		11.10 Loss of network communication	37
		11.11 Modbus® protocol on the UEY boards	38
		11.12 Exceptions managed	38
		12. ADVANCED FUNCTIONS	39
		12.1 Operating principle	39
		12.2 Control principles	39
		12.3 Supply water conductivity	39
		12.4 Automatic draining	39
		12.5 Automatic insufficient supply water management	40
		12.6 12.6 Alarm relay switching	40
		12.7 Auxiliary contact management (active fan request)	40
		12.8 Manual procedure	40
		12.9 LEDs on the control board	40

1. INTRODUCTION AND ASSEMBLY

1.1 humiSteam (UEY*)

Range of isothermal immersed electrode humidifiers with backlit display for the control and distribution of steam.

Models available (identifiable from the code shown on the product):

- UE005, UE008, UE010, UE015, with steam production capacity up to 15 kg/h, water connections under the base of the humidifier;
- UE025, UE035, UE045, UE065 with steam production capacity from 25 to 65 kg/h, water connections on the side of the humidifier.

1.2 Dimensions and weights

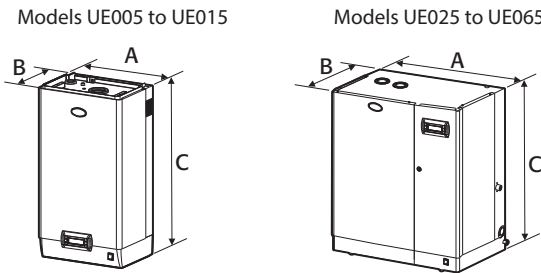

Fig. 1.a

		UE005 to UE008	UE010 to UE015	UE025 to UE045	UE065
dimensions mm (")	A	365 (14.4)		545 (21.5)	635 (25.0)
	B	275 (10.8)		375 (14.8)	465 (18.3)
	C	712 (28.0)		815 (32.0)	890 (35.0)
weights kg (lb)	packaged	16 (35.3)	20 (44.0)	39 (86.0)	51 (112.4)
	empty	13,5 (29.8)	17 (37.5)	34 (74.9)	44 (97.0)
	installed*	19 (41.9)	27 (59.5)	60,5 (133.4)	94 (207.2)

Tab. 1.a Tab. 1.a

*: in operating conditions

1.3 Opening the packaging

- make sure the humidifier is intact upon delivery and immediately notify the transporter, in writing, of any damage that may be due to careless or improper transport;
- move the humidifier to the site of installation before removing from the packaging, grasping the neck only from underneath the base;
- open the cardboard box, remove the protective material and remove the humidifier, keeping it vertical at all times.

1.4 Positioning

- the unit is designed to be mounted on a wall that is strong enough to support the weight in normal operating conditions (see Wall-mounting below). Models UE025 to UE065 can stand on the floor;
- to ensure correct steam distribution, position the humidifier near the point of steam distribution;
- make sure the humidifier is level, allowing the minimum clearances (see Fig. 1.b) for maintenance operations.

! Important: during operation the metal casing heats up and the rear part resting against the wall may reach temperatures in excess of 60 °C (140 °F).

Distances from walls

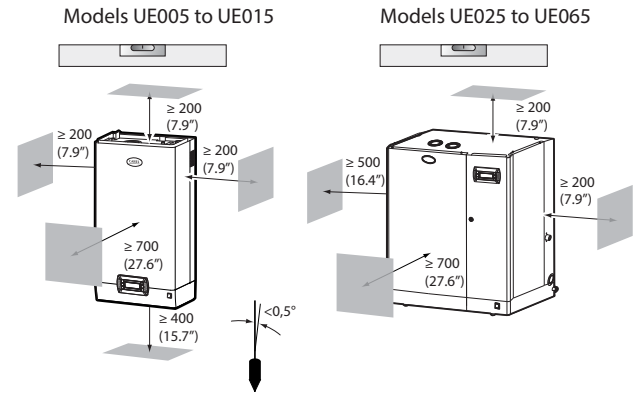

Fig. 1.b

1.5 Wall-mounting

Fit the humidifier on the wall using the support bracket and the screw kit supplied (for the dimensions in mm see Fig. 1.d).

Assembly instructions:

1. unscrew the wall bracket from the humidifier bracket;
2. fasten the wall bracket (see Fig. 1.e), checking horizontal position with a spirit level; if installed on a masonry wall, the plastic anchor plugs (dia. 8 mm/0.31") and screws (dia. 5 mm x L= 50 mm/ 0.19" x L= 1.97") supplied can be used;
3. hang the appliance to the bracket using the slot on the top edge of the rear of the appliance;
4. secure the appliance to the wall through the hole in the centre of the rear of the unit. For the weights and dimensions see Figs. 1.a, 1.b, 1.c.

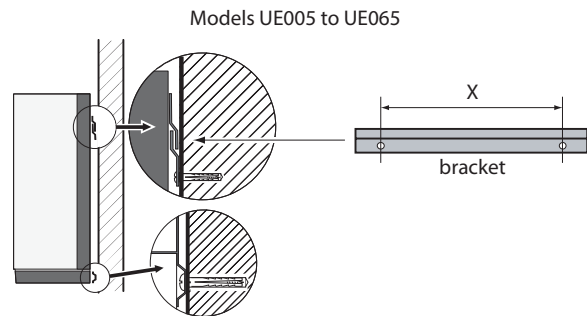
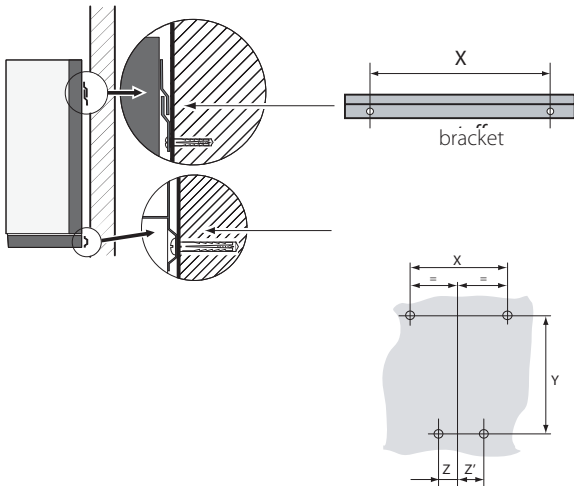

Fig. 1.c

Spacing of the holes on the wall
Models UE005 to UE015



Models UE025 to UE065

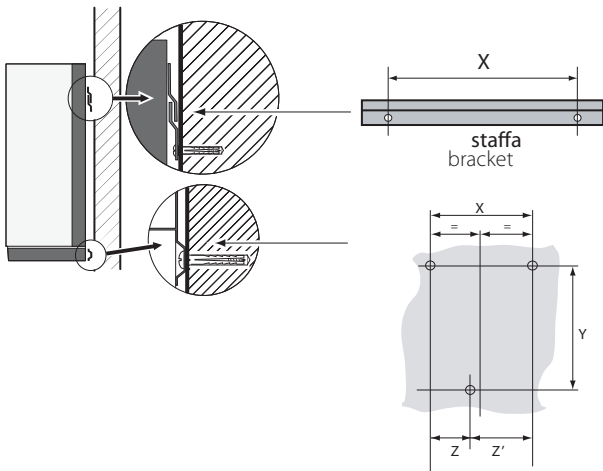

Fig. 1.d

distance mm (")	Models			
	UE005 to UE008	UE010 to UE015	UE025 to UE045	UE065
X	270 (10.7)	270 (10.7)	310 (12.2)	400 (15.7)
Y	591 (23.3)		655 (25.8)	730 (28.7)
Z	107(4.2)	107(4.2)	127.5 (5.0)	122.5 (4.8)
Z'	163(6.4)	163(6.4)	172.5 (6.8)	167.5 (6.6)

1.6 Removing the front cover

Models UE005 to UE015:

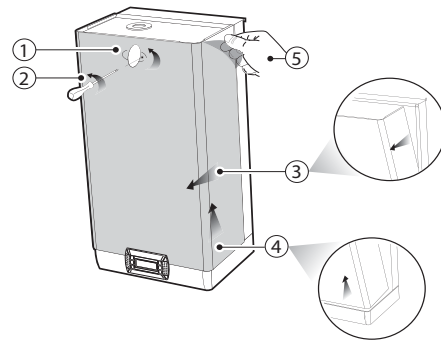

Fig. 1.e

1. turn oval-shaped label with the Carel logo, revealing the head of the earth screw below;
2. remove the screw using a screwdriver;
3. hold the cover by the sides and tilt;
4. remove the cover by moving to the bottom;
5. remove the protective film

Models UE025 to UE065:

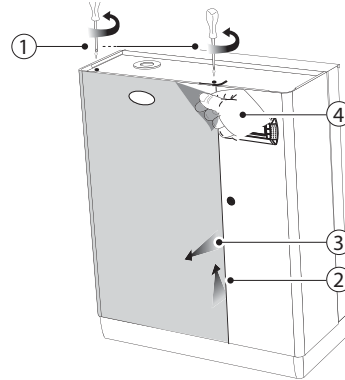

Fig. 1.f

1. remove the screws from the top of the humidifier using a screwdriver;
2. hold the cover/covers from the top and lift it around 20 mm (0.79");
3. remove the cover/covers by moving it/them forwards;
4. remove the protective film (on all the outside surfaces of the humidifier).

1.7 Fitting the front cover

Models UE005 to UE015:

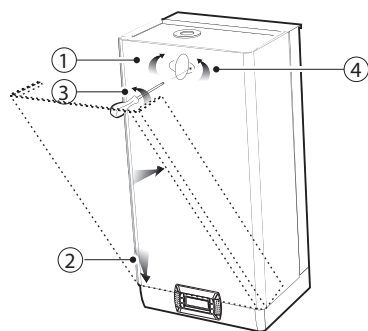

Fig. 1.g Fig. 1.g

1. turn the red oval-shaped plate with the CAREL logo, revealing the fastening hole below;
2. slip the cover onto the frame (keeping it slightly oblique), until it rests on the rear edges, paying attention to the positioning holes on the side;
3. tighten the earth screw using a screwdriver;
4. turn the red oval-shaped plate with the CAREL logo until covering the fastening hole below.

Modelli UE025...UE065:

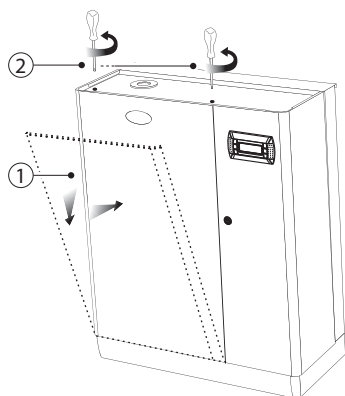

Fig. 1.h

1. slip the cover/covers onto the frame (keeping it/them slightly raised and tilted), until it rests on the rear edges;
2. tighten the screws on the top of the humidifier using a screwdriver.

⚠ Important: in models UE025 to UE065 open the electrical compartment on the humidifier using the lock with slot.

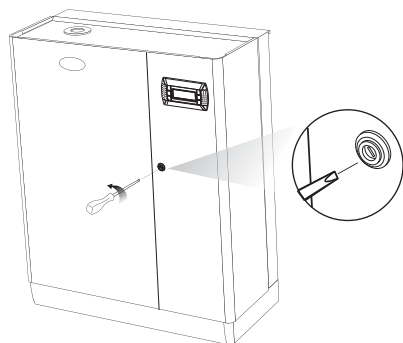

Fig. 1.i

1.8 Components and accessories

Once having opened the packaging and removed the front cover of the humidifier, make sure the following are included:



- kit of screws with plugs for wall-mounting



- kit code 98C615P003 of connectors for the electronic board



- models UE025 to UE065 only: code FWHDCV0000 non-return valve with connection pipe



- models UE025 to UE065 only: angular plastic hose (drain water connection)..

2. WATER CONNECTIONS

! Important: before proceeding, disconnect the humidifier from the power supply.

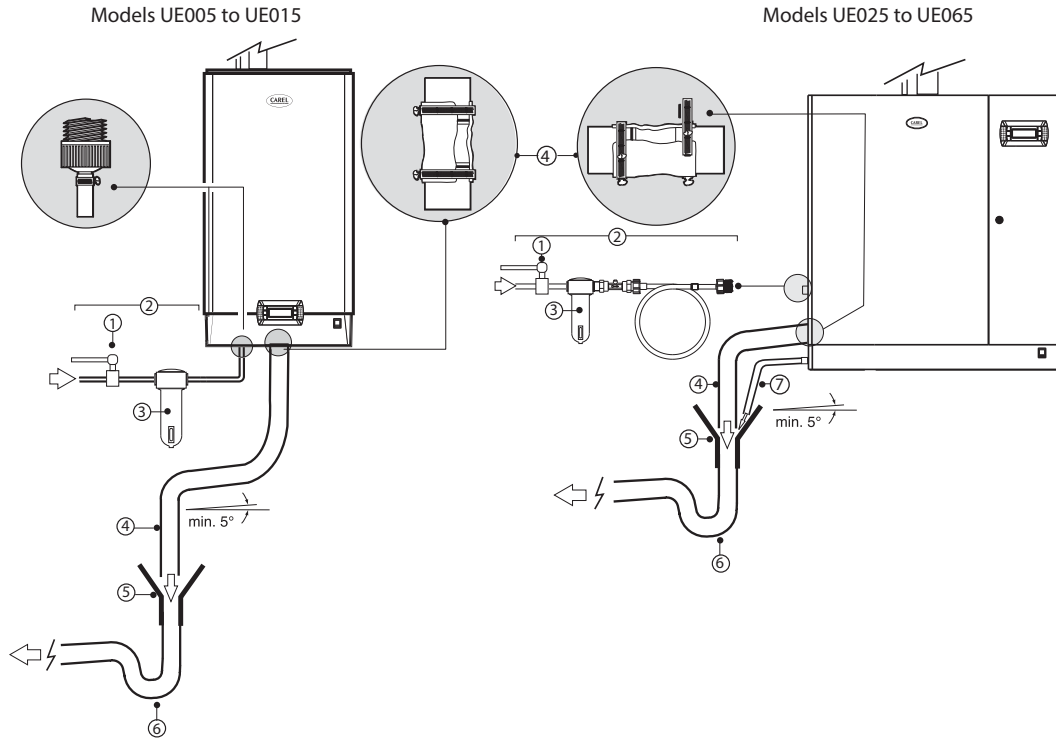

Fig. 2.a

Water connections:



- 1. install a manual valve upstream of the installation (to be able to cut off the water supply);
- 2. connect the humidifier to the water supply. On models UE005 to UE015, use a hose with 3/4"G fittings (see par. 11.2 "Technical specifications", compatible CAREL hose: code FWH3415000). On models UE025 to UE065 connect the hose with the non-return valve supplied (code FWHDCV0000) to prevent the water inside the humidifier from coming into contact with the mains water;
- 3. install a mechanical filter to trap any solid impurities (to be connected downstream of the tap);
- 4. connect a section of non-conductive pipe or hose for draining (resistant to temperatures of 100 °C (212 °F) and with a minimum inside diameter of 40 mm/1.6");
- 5. prepare a funnel to interrupt continuity in the drain line;
- 6. connect a drain trap to prevent the return of bad odours (minimum inside diameter 40 mm/1.6");
- 7. in models UE025 to UE065: connect a drain hose (minimum inside diameter 15 mm (0.59")) from the bottom tank of the humidifier (this can run into the drain funnel).



Important: when installation is completed, flush the supply hose for around 30 minutes by piping water directly into the drain, without sending it into the humidifier. This will eliminate any scale or processing residues that may block the drain pump and cause foam when boiling.

Fittings provided for the water connections:

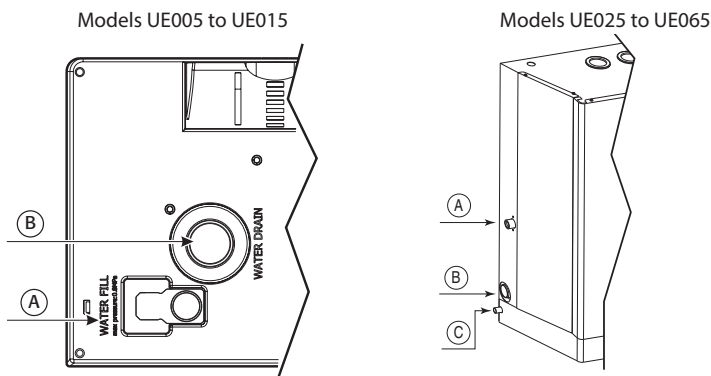

Fig. 2.b

Key:

- A. supply water inlet
- B. drain water outlet
- C. bottom tank drain water outlet (models UE025 to UE065 only)

Hydraulic interfaces dimensions

Interfaces dimensions
drain/fill

dimensions mm (inc)	UE005 to UE015
D	72.6 (28.6)
D'	125.4 (49.4)
E	52.6 (20.7)
E'	107.5 (42.3)

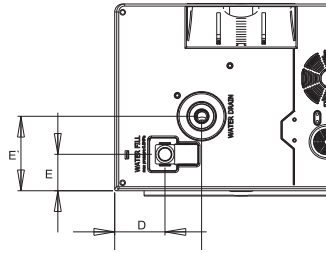

Interfaces dimensions
steam outlet and condensed
drain

dimensions mm (inc)	UE005 to UE015
F	126.7 (50.0)
F'	224 (88.2)
G	137.9 (54.3)
G'	21.7 (8.6)

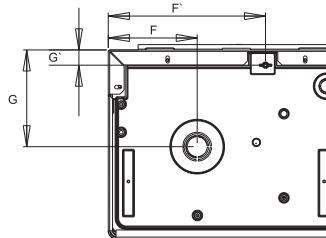

Interfaces dimensions
drain/fill

dimensions mm (inc)	UE025 to UE065
I	40 (15.8)
I'	72 (28.3)
I''	10.2 (4.0)
L	123.2 (48.5)
L'	231.2 (91.0)
L''	49.1 (19.3)

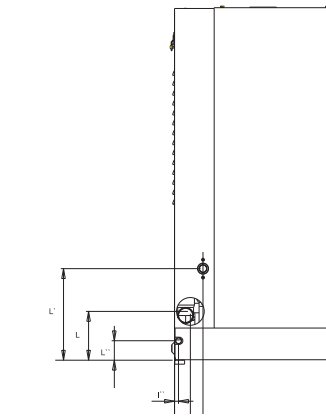

Interfaces dimensions
steam outlet and condensed
drain

dimen. mm (inc)	UE025 to UE045	UE065
M	172 (67.7)	223.7 (88.1)
M'	30.2 (11.9)	30.2 (11.9)
N	181 (71.3)	181 (71.3)
N'	---	100 (39.4)
N''	55 (21.7)	61 (24.0)

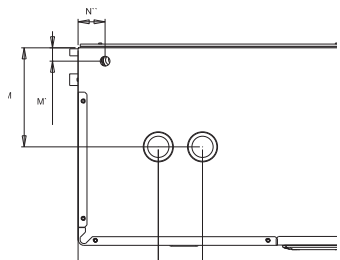

2.1 Supply water

Only use mains water with:

- pressure between 0.1 and 0.8 MPa (14.5 and 116 PSI), temperature between 1 and 40 °C (33.8 and 104 °F) and an instant flow-rate no lower than the rated flow of the fill solenoid valve, the connection is G3/4M (see par. "11.2 Technical specifications");
- hardness no greater than 40 °f (equal to 400 ppm of CaCO₃), conductivity: 75 to 1250 µS/cm;
- no organic compounds.

supply water characteristics	unit of measure	normal water		water with low salt content	
		min.	max.	min.	max.
Hydrogen ions (pH)		7	8.5	7	8.5
Specific conductivity at 20°C (σ _{R, 20 °C})	µS/cm	300	1250	75	350
Total dissolved solids (c _R)	mg/l	(¹)	(¹)	(¹)	(¹)
Dry residue at 180°C (R ₁₈₀)	mg/l	(¹)	(¹)	(¹)	(¹)
Total hardness (TH)	mg/l CaCO ₃	100 (²)	400	50 (²)	150
Temporary hardness	mg/l CaCO ₃	60 (³)	300	30 (³)	100
Iron + Manganese	mg/l Fe+Mn	=	0,2	=	0,2
Chlorides	ppm Cl	=	30	=	20
Silica	mg/l SiO ₂	=	20	=	20
Residual chlorine	mg/l Cl-	=	0,2	=	0,2
Calcium sulphate	mg/l CaSO ₄	=	100	=	60
Metallic impurities	mg/l	0	0	0	0
Solvents, thinners, detergents, lubricants	mg/l	0	0	0	0

Tab. 2.a

(¹)= values depend on the specific conductivity; in general:

TDS ≈ 0,93 * σ_{R, 20 °C}; R₁₈₀ ≈ 0,65 * σ_{R, 20 °C}

(²)= not less than 200% of the chloride content in mg/l CL

(³)= not less than 300% of the chloride content in mg/l CL

There is not reliable relationship between hardness and conductivity of the water

Important:

- do not treat the water with softeners, this may cause the entrainment of foam, affecting the operation of the unit;
- do not add disinfectants or anticorrosive compounds to the water, as these are potential irritants;
- the use of well water, industrial water or water from cooling circuits and, in general, any potentially chemically or bacteriologically contaminated water is not recommended.

2.2 Drain water

this contains the same substances dissolved in the supply water, however in larger quantities;

- it may reach a temperature of 100 °C (212 °F);
- it is not toxic and can be drained into the sewerage system.

3. STEAM DISTRIBUTION

3.1 CAREL jet distributors (SDPOEM00**)

These can be fitted horizontally or vertically (hole facing upwards). See page 31 for the models of distributors.

Assembly instructions (see Fig.3.a):

- make a series of holes on the wall according to the distributor drilling template;
- insert the distributor;
- fasten the flange using 4 screws.

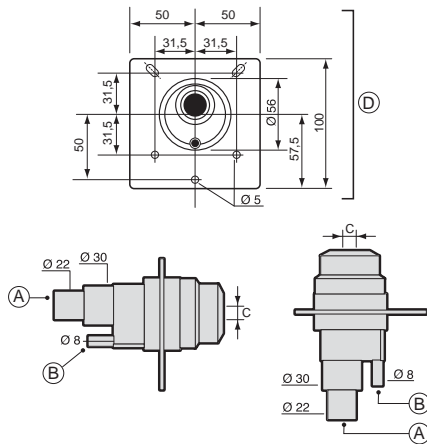

Fig. 3.a

Key:

- A. steam inlet
 - B. condensate drain
 - C. steam outlet.
- the dimensions of the hole vary depending on the models of distributor:
 model SDPOEM0000: hole made manually, up to 30 mm (1.2") in diameter);
 model SDPOEM0012: diameter of the hole 12 mm (0.5");
 model SDPOEM0022: diameter of the hole 22 mm (0.9").
- D drilling template

Note: if steam hoses with an inside diameter of 30 mm (1.2") are used, remove the 22 mm (0.9") steam inlet section.

3.2 CAREL linear distributors for air ducts (DP***DRO)

Install away from obstacles (curves, branches, changes in cross-section, grills, filters, fans).

Minimum distance between the distributor and the obstacle: 1/1.5 m (3.3/4.9 ft). Increase the distance if:

- the air speed increases in the duct,
- the relative humidity of the air increases before and after humidification,
- the turbulence decreases.

See page 33 for installation examples.

Assembly instructions (see Fig.3.b):

- make a series of holes on the wall according to the distributor drilling template (included in the packaging with the distributor);
- insert the distributor with the steam hole

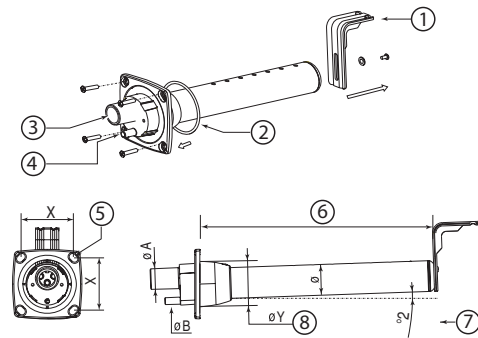

Fig. 3.b

Key:

- 1 "L"-shaped mounting support (where featured)
- 2 flange gasket
- 3 steam inlet (ØA)
- 4 condensate drain (ØB)
- 5 screw diameter (see the instruction sheet supplied with the distributor)
- 6 length (depending on the model of distributor, see par. "10.5" page 38)
- 7 angle (around 2°) for draining the condensate.
- 8 diameter of the hole on the wall (ØY)

Dimensions in mm (in)

	CAREL linear distributors		
	DP***D22R0	DP***D30R0	DP***D40R0
ØA	22 (0.9")	30 (1.18")	40 (1.57")
ØB	10 (0.4")	10 (0.4")	10 (0.4")
ØY	58 (2.3")	68 (2.7")	89 (3.5")
Ø	35 (1.4")	45 (1.8")	60 (2.4")
X	68 (2.7")	77 (3.0")	99 (3.9")

Tab. 3.b Tab. 3.a

Important:

- 1. fit the distributor at a slight incline (at least 2°, to prevent the return of condensate);
- 2. the "L"-shaped mounting support (see part 1 Fig. 3.c) is supplied with steam distributor models from DP085* to DP025*. For shorter lengths, the support can be supplied as an option (code 18C478A088).

3.3 CAREL steam blowers (VSDU0A*, models UE005 to UE015 only)

Steam distributors for humidifiers with flow rates up to 15 kg/h. Can be connected on top of the humidifier, or separately in another location (see the figure below).

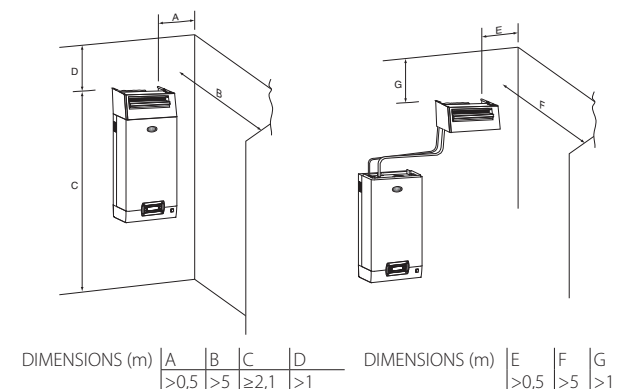

Fig. 3.c

Important: For correct distribution of the steam, observe the distance shown in the figure above.

CAREL

3.4 Steam hoses

- use CAREL hoses (max. 4 m long, see "Models of steam hoses", page 30). Rigid pipes may break and cause steam leaks;
- avoid the formation of pockets or traps (causes of condensate);
- avoid choking the hose due to tight bends or twisting.
- fasten the end of the hose to the connectors on the humidifier and the steam distributor using metal clamps, so that these do not detach due to the high temperature.
- avoid solicitations involving stress on the shank out of steam cylinder.

3.5 Condensate drain hose

During the operation of the humidifier some of the steam may condense, causing a decline in efficiency and noise (gurgling). To drain the condensate, connect a drain hose with a drain trap and a minimum slope of 5° to the bottom of the humidifier (see Fig. 3.d). CAREL condensate drain hoses: code 1312353APG

! Important: he drain trap in the condensate drain hose must be filled with water before starting the humidifier.

Example of correct and incorrect installation of the steam hose and condensate drain hose.

Final checks

- the steam outlet hoses run upwards and the distributor has a minimum incline of 2° upwards (see Fig. 3.c);
- the ends of the hose are tightened to the fittings with metal clamps;
- the curves in the tubing are sufficiently wide (radius > 300 mm / 11.8") so as to not cause bending or choking;
- the steam hose has no pockets or traps for condensate to form;
- the paths of the steam and condensate hoses are as described in this chapter (see Fig. 3.d);
- the length of the steam hose is no greater than 4 metres (13.1 feet);
- the incline of the steam hose is sufficient to allow correct draining of the condensate (> 20° for the upward sections, > 5° for the downward sections);
- the incline of the condensate hose is at least 5° at every point;
- the condensate hose always follows a downwards path and features a drain trap (filled with water before starting operation) to avoid steam being released.

YES

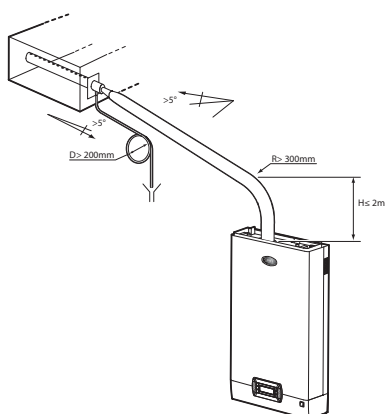

YES

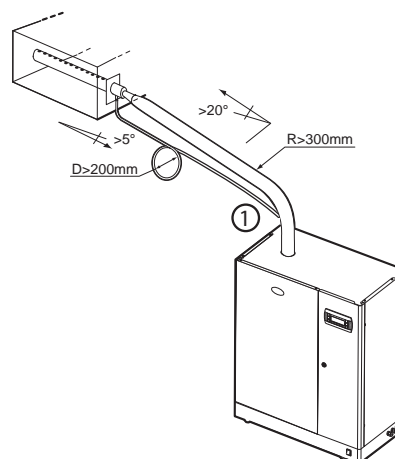

All UE models

Models UE25 to UE130
(1) extend the hose inside the humidifier to the bottom tank.

YES

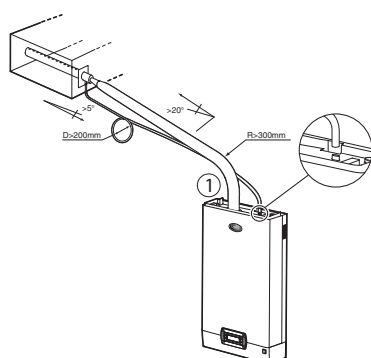

Models UE005 to UE025
(1): connection with fill tank

NO

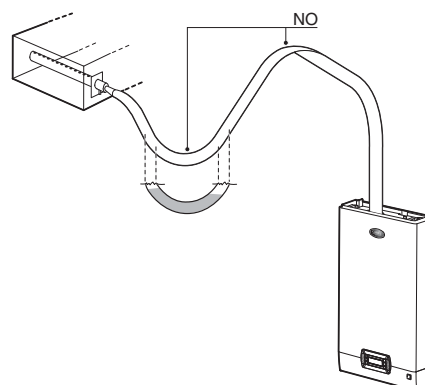

All UE models

4. ELECTRICAL CONNECTIONS

4.1 Preparing the electric cableways

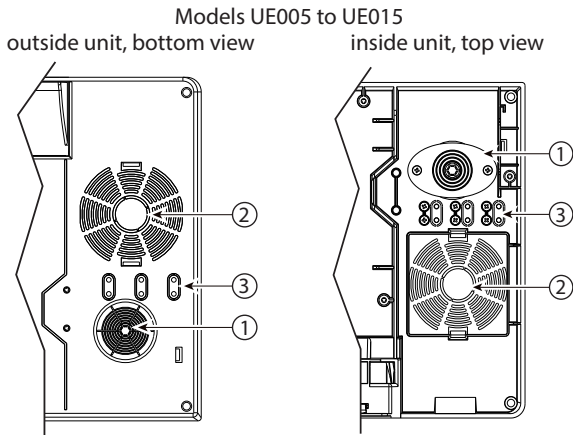

Fig. 4.a

Models UE025 to UE065: outside unit, side view

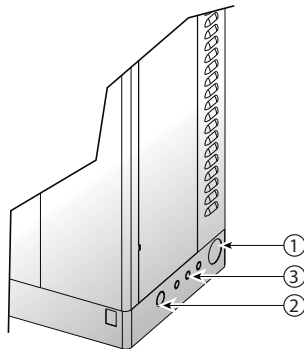

Fig. 4.b

Key to Figs. 4.a & 4.b:

1. power cable inlet;
2. optional utility cable inlet (after drilling).
3. probe cable inlet. On models UE005 to UE015, remove the plastic "tab" and use it to secure the cable (held in place by the screws provided).

4.2 Power cable connection

Before making the connections, ensure that the machine is disconnected from the mains power supply.

Check that the power supply voltage of the appliance corresponds to the value indicated on the rating plate inside the electrical panel. Insert the power and ground connection cables into the electrical panel compartment using the tear-proof cable gland supplied, or through the cable gland with cable stop, and connect the ends to the terminals (see Fig. 4.c). The humidifier power line must be fitted, by the installer, with a disconnecting switch and fuses protecting against short circuits. Table 11.a lists the recommended cross-sections of the power supply cable and the recommended fuse ratings; note, however, that this data is purely a guide and, in the event of non-compliance with local standards, the latter must prevail.

Note: to avoid unwanted interference, the power cables should be kept apart from the probe signal cables.

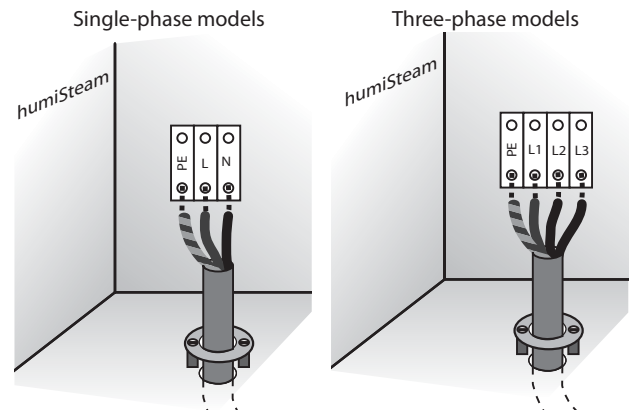

Fig. 4.c (view inside unit, electrical compartment)

Important: connect the yellow-green cable to the earth point (GND).

4.3 Steam production control signals (M2.1 - M2.7)

Depending on the type of signal used, steam production can be enabled and/or managed in different ways (ON/OFF or modulating)..

Steam production is enabled by keeping terminals M2.4 and M2.5 closed.

1. Enable steam production using: HUMIDISTAT (ON/OFF action)

- connect inputs M2.2 and M2.3 (production request) to a humidistat;
- jumper inputs M2.4 and M2.5 (enable);
- set parameter A0=0 to enable the ON/OFF action.

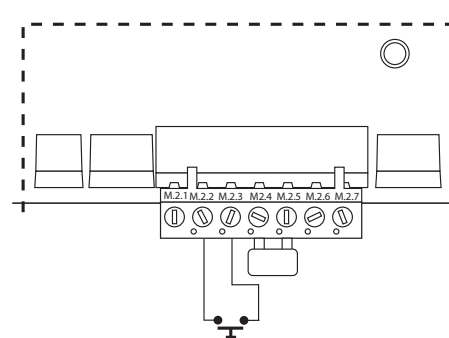

Fig. 4.d

HUMIDISTAT and REMOTE CONTACT (ON/OFF action)

- connect inputs M2.2 and M2.3 (production request) to a humidistat;
- connect inputs M2.4 and M2.5 (enable) to a remote contact (e.g.: switch, timer,...)
- set parameter A0=0 to enable the ON/OFF action.

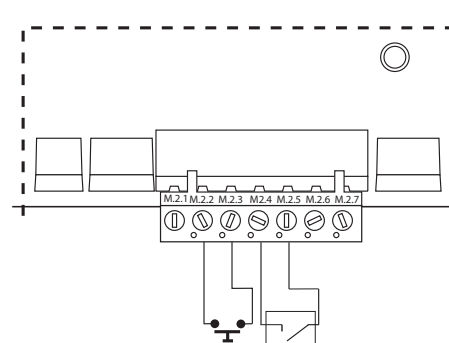

Fig. 4.e

CAREL

2. Enable and control steam production using:
 PROPORTIONAL EXTERNAL CONTROLLER (modulating action)
- jumper inputs M2.4 and M2.5 (enable)
 - connect outputs M2.2 and M2.3 (production request) to an external controller
 - set parameter A0=1 to enable the modulating action (see chap. 7) and parameter A2 depending on the signal chosen (0 to 10 V, 2 to 10V, 0...20mA, 4 to 20 mA) (see chap. 7).

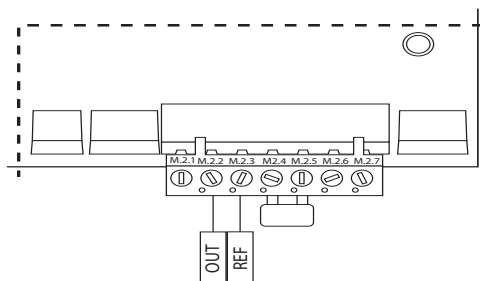

Fig. 4.f

- PROPORTIONAL EXTERNAL CONTROLLER and REMOTE CONTACT (modulating action)
- connect inputs M2.4 and M2.5 to a remote contact (enable)
 - connect outputs M2.2 and M2.3 (request) to an external controller
 - set parameter A0=1 to enable the modulating action (see chap. 7) and parameter A2 depending on the signal chosen (0 to 10 V, 2 to 10V, 0...20V, 4 to 20 mA) (see chap. 7).

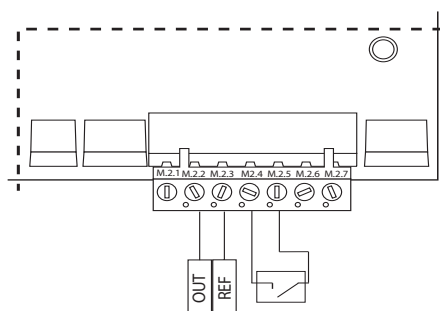

Fig. 4.g

Note: in industrial environments (IEC EN61000-6-2) the signal cables running from the unit must not exceed 10 m (33 ft)⁽¹⁾ in length: steam production signal cable (terminals M2.1...M2.3), remote on/off input (terminals M2.4...M2.5) and cable shields for RS485 communication.

CONTROL WITH CAREL MAIN PROBE

- jumper inputs M2.4 and M2.5 (enable)
- connect the main probe to terminals M2.1, M2.2 e M2.3
- set parameter A0=2 to enable the main probe (see chap. 7) and parameter A2 depending on the signal chosen (0...10 V, 2...10 V, 0...20 mA, 4...20 mA) (see chap. 7).

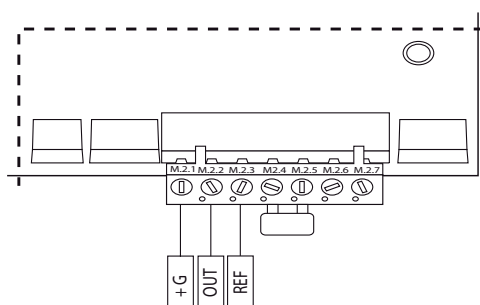

Fig. 4.h

CONTROL WITH CAREL MAIN PROBE AND REMOTE CONTACT

- connect inputs M2.4 and M2.5 to a remote contact (enable)
- connect the main probe to terminals M2.1, M2.2 e M2.3

- set parameter A0=2 to enable the main probe (see chap. 7) and parameter A2 depending on the signal chosen (0...10 V, 2...10 V, 0...20 mA, 4...20 mA) (see chap. 7).

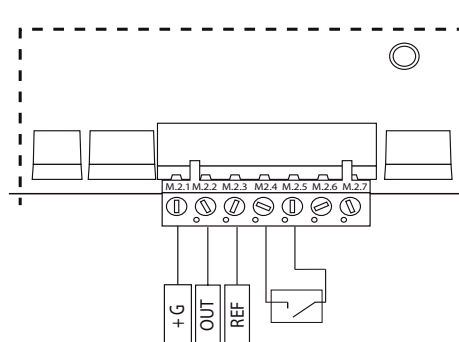

Fig. 4.i

CONTROL WITH CAREL NTC PROBE

- jumper inputs M2.4 and M2.5 (enable)
- connect the probe to terminals M2.2 e M2.3
- set parameter A0=2 to enable the probe (see chap. 7) and parameter A2=5 (NTC).

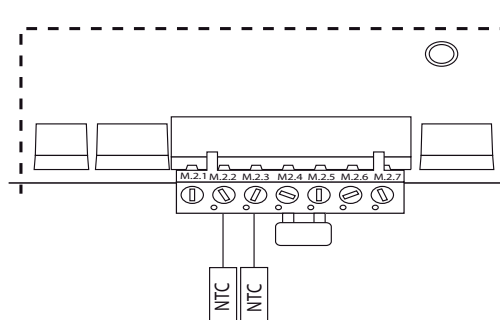

Fig. 4.j

CONTROL WITH CAREL NTC PROBEL and REMOTE CONTACT

- connect inputs M2.4 and M2.5 to a remote contact (enable)
- connect the probe to terminals M2.2 e M2.3
- set parameter A0=2 to enable the probe (see chap. 7) and parameter A2=5 (NTC).

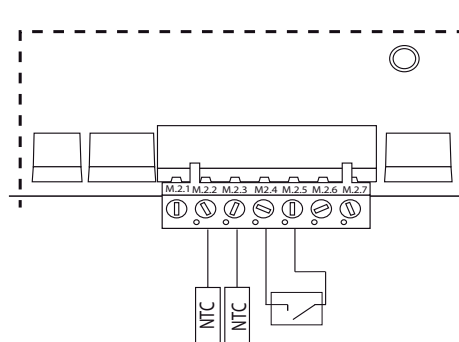

Fig. 4.k

CAREL PROBES AVAILABLE FOR DEFAULT (0-10V)

- room: cod. DPWC112000
- air ducts: cod. DPDC112000 e cod. DPDC212000
- industrial: cod. DPPC112000 e DPPC212000

If non-CAREL probes are used, check:

- voltage signal: 0...10 Vdc, 2...10 Vdc, terminal M2.2 (GND: M2.3);
 - current signal: 4...20 mA, 0...20 mA, terminal M2.2 (GND: M2.3).
- In addition, depending on the type of power supply:
- +15 V, terminal M2.1.

4.4 Alarm contact (M5.1 - M5.2)

Contact available for the remote signalling of one or more alarms.

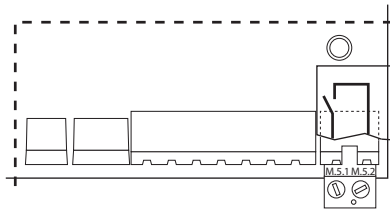

Fig. 4.l

Electrical specifications: 250 Vac; I_{max}: 2 A resistive 2 A inductive.

Note: use clamps on the relay terminal blocks (alarm, utilities) to prevent the cables from being detached.

4.5 Auxiliary contact: prod. request present, external fan control (M14.1 - M14.3)

Relay contact that indicates the presence of the steam production request. It can also be used to control an external fan (see chap. 12.7)

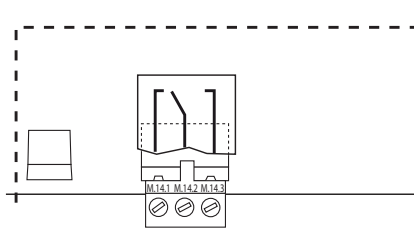

Fig. 4.m

Electrical specifications: 250 Vac; I_{max}: 8 A resistive 2 A inductive.

Final checks

The following conditions represent correct electrical connection:

- the rated voltage of the appliance corresponds to the rated supply voltage;
- the fuses installed are suitable for the line and the power supply voltage;
- a mains disconnect switch has been installed to disconnect power to the humidifier when required;
- the humidifier has been correctly earthed;
- the power cable is fastened using the tear-proof cable gland;
- terminals M2.4 and M2.5 are jumpered or connected to an enable-operation contact;
- if the humidifier is controlled by an external control device, the earth of the signal is electrically connected to the controller earth.

5. REMOTE TERMINAL AND SUPERVISORY NETWORK

5.1 Remote display terminal

The display terminal can be detached from the humidifier and moved up to 30 m (98 feet) away.

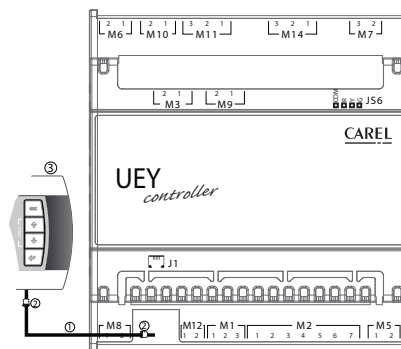

Fig. 5.a

Key:

- 1 telephone cable 6 wires (up to 10 m (33 ft)⁽¹⁾ / 98 feet distance);
- 2 two EMC filters (code 0907858AXX) to be applied to the ends of the telephone cable;
- 3 remote display terminal.

Note: to fill the empty space left by the display terminal on the humidifier, use CAREL kit code HCTREW0000.

⁽¹⁾ For lengths greater than 10 m (33 ft) use shielded cable with the shield connected to PE both on the terminal side and the controller side

5.2 RS485 supervisory network (M1.1-M1.3)

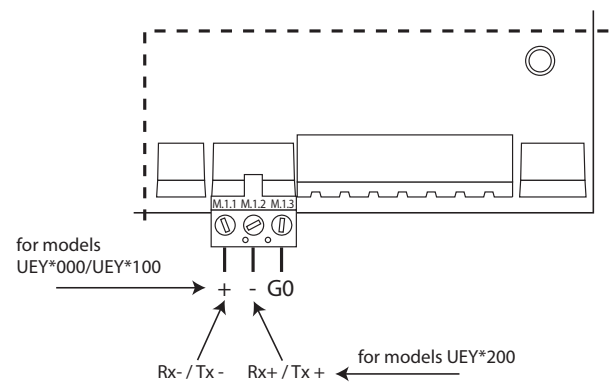



Fig. 5.b

Important: for the RS485 connections in household (IEC EN 55014-1) and residential (IEC EN 61000-6-3) environments, use shielded cable (with shield connected to PE both on the terminal side and the controller side) with maximum shielded cable length: specified by the EIA RS485 protocol, equivalent to European standard CCITT V11, using shielded twisted pair cable, AWG26, 485 input stage impedance 1/8 unit-load (with this configuration, a maximum of 256 devices can be connected) laid in separate conduits from the power cables.

6. STARTING AND USER INTERFACE

Before starting the humidifier, check:

-  water connections: chap. 2. In the event of water leaks do not start the humidifier before having resolved the problem;
- steam distribution: chap. 3 and electrical connections chap. 4.

6.1 Starting

- 1  if the cylinder is new, run a pre-wash cycle by pressing ENTER + DOWN for 5 sec. (the cylinder is filled and emptied three times, cleaning the inside walls from impurities). A display shows the symbol PRE Cln

6.2 Stopping

- 1 empty the water in the cylinder to avoid stagnation (see paragraph 6.12 "Manually drain the water in the cylinder").
- 2 

6.3 Display

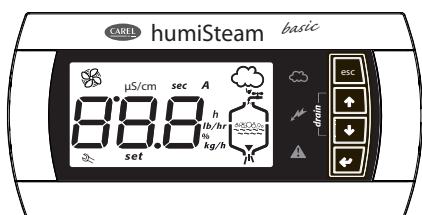













Fig. 6.a

- Key:
-  manually drain the cylinder (see paragraph 6.6)
 -  power supply (green LED)
 -  humidifier operating (yellow LED)
Flashing: steam production not yet in steady operation
Steady: steam production in steady operation
 -  alarm (red LED, not flashing)
Alarm activated: LED flashing and buzzer active
If an alarm is active pressing ESC mutes the buzzer and the LED comes on steady, pressing ESC again resets the alarms (see Chap. 8)

- µS/cm** conductivity value
- sec** time in seconds
- A** instant current value in Amperes
- h** real hour counter
- lb/hr** steam flow-rate (Imperial system)
- %** steam production as a percentage of rated capacity
- kg/h** steam flow-rate (international system, default)
- set** parameter programming in progress (parameter setup)
-  maintenance request (alarm active) or display alarm log (HYS)
-  on steady: external fan or steam production active. Flashing: external fan or steam production awaiting start/stop

Key:
888 3 digits, after 999 the display shows **100** to indicate 1000 (only three digits plus point - between the first and the second digit- are displayed).

-  steam production in progress
-  cylinder filling in progress
-  foam in the cylinder
-  presence water in the cylinder
-  cylinder water drain in progress

6.4 Keypad

key	function
Esc	return to the previous display from the main screen: pressed for 5 seconds disables/ enables the humidifier
↑ UP	from the main screen: display the humidification values (current, conductivity,...), see the following paragraph from the list of parameters: circular navigation of the parameters and set the values
↓ DOWN	from the main screen: display the humidification values (current, conductivity,...) from the list of parameters: circular navigation of the parameters and set the values
← ENTER (PRG)	for 2 seconds: access the list of parameters from the list of parameters: select and confirm (like the "Enter" key on a computer keyboard)

6.5 Main display

The display on the humidifier normally shows the current steam production (kg/h, basic display).
To display other values, press UP or DOWN and scroll the following list:

- current (A);
- conductivity (µS/cm);
- real hour counter (h);
- input signal displayed:

A0	A1	A2	A3	A4	A5	Display	Function
0	-	-	-	-	-	ON/OFF	ON/OFF
1	-	1..4	-	-	-	0...100%	external regulator
2	-	1..4	0...100	0...100	0...100	0...100% U.R.	humidity probe
3	0	5	0...100	0...100	0...100	0...100 °C	temperature probe
3	1	5	0...100	0...100	0...100	0...212 °F	temperature probe

Tab. 6.c

- set maximum steam production (parameter P0) (*);
 - humidification differential regulation (parameter P1) (***);
 - outlet set point regulation (parameter st) (****);
 - access alarm log (HYS) (**);
- To return to the basic display, press ESC.
Parameter C0 (see chap. 7) can be used to change the value of the basic display (default: current steam production).
- (*) To modify the maximum steam output (P0) press:
- ENTER (display: **set**)
 - UP or DOWN to set the value percentage of production (from 20 to 100%)
 - ENTER to confirm the new value

Press ESC to return to the main screen
Parameter P0 can also be accessed from the list of parameters (see chap. 7).

(**) To display the alarm log (HYS) press:

- ENTER (the most recent alarm is shown)
- UP or DOWN to scroll the list of alarms in chronological order

press ESC to return to the main screen

To delete the list of alarms press UP and DOWN for 5 seconds (inside the alarm log), when the list has been reset the display will show 'res'.

(***) To modify the humidification differential (P1) press:

- ENTER (display: **set**)
- UP or DOWN to modify humidification differential value (from 2 to 19.9)
- ENTER to confirm the new value

Press ESC to return to the main screen

Parameter P1 can also be accessed from the list of parameters (see chap. 7).

(****) To modify outlet set point (st) press:

- ENTER (display: **set**)
- UP or DOWN to modify the set point (from 0 to 100)
- ENTER to confirm the new value

Press ESC to return to the main screen

Parameter "st" can also be accessed from the list of parameters (see chap. 7).

6.6 Disabling

The humidifier can be disabled in 3 different ways:

- Opening contact M2.4 and M2.5 (enable) : the display shows C--
- From serial (see Chap. 7 Digital 2) : the display shows S--
- From terminal (see ESC button) : the display shows t--

6.7 Recalling the manufacturer defaults

From the main screen press ENTER until the password screen is shown:

- Enter the password 50
- The message dEF is displayed, flashing

Confirm by pressing ENTER or exit by pressing ESC

If no button is pressed for 30 seconds, the display returns to the main screen.

6.8 Display software release

1) when switching on the unit to display "rel. x.y"(example rel. 1.2)

2) during operation

a) display: from main screen press ESC and UP appear in sequence: the size dell'umidificatore, the voltage, the number of phases and the software release

b) via network using integer variable 81. Format = # # #. # "(e.g. 12 = release 1.2)".

6.9 Match digit (match between the softwares of board and terminal)

humiSteam basic verifies the matching between the softwares of the controller and the terminal at the start-up. The 8th digits for board and 9th for terminal of both codes must be equal.

If there is no match, on power-up after displaying the software release, and in normal operation when pressing UP+PRG, the red LED will remain on for 5 seconds, and the following error message will be displayed:

"X - Y", where "X" and "Y" are the 2 different 8th digits. Refer to the after-sales service.

6.10 Reset cylinder hour counters

- Access parameter 'da' (see chap. 7)
- press UP and DOWN for 5 seconds

When the counter has been reset, the display shows 'res'.

6.11 Parameters: Saving/recalling the user settings

From the main screen, a copy of the user settings can be saved at any time, and then later recalled.

To save the settings:

From the main screen press:

- ENTER for 2 seconds,
- enter the password 51 using the UP or DOWN button and press ENTER, the message UbP (Backup User parameters) flashes
- press ENTER: the message -L- is displayed, flashing
- press UP or DOWN, the message -S- (Save) is displayed, flashing,
- press ENTER to save a copy of the user settings, or press ESC to cancel the operation

NOTE: the copy of the user parameters saved previously will be overwritten with current user settings.

To recall the settings:

From the main screen press:

- ENTER for 2 seconds,
- enter the password 51 using the UP or DOWN button and press ENTER, the message UbP (Backup User parameters) flashes
- press ENTER: the message -L- (Loading) is displayed flashing,
- press ENTER to recall the previously saved copy of the user settings, or press ESC to cancel the operation.

If no button is pressed for 30 seconds, the display returns to the main screen, without performing the operation.

6.12 Manually drain the water in the cylinder

Total drain on power-up

Switch on the humidifier while holding UP and DOWN until the cylinder and drain symbols are shown (the message 'dr' on the display alternating with 'tot' indicates the function has been activated). To stop the function before completion press UP and DOWN for 5 seconds

Total drain in operation

Press UP and DOWN together for 2 seconds (the message 'dr' on the display alternating with 'tot' indicates the function has been activated). Press UP and DOWN again for 2 seconds to stop the drain cycle. The drain cycle in any case ends automatically.

7. CONFIGURATION PARAMETERS

7.1 Accessing and setting the parameters

The configuration parameters are used to select and control the functions and the status of the humidifier.

From the main screen press:

- ENTER for 2 seconds,
- enter the password 77 using UP or DOWN,
- ENTER to confirm and access the list of parameters,
- UP or DOWN to scroll the list cyclically,
- ENTER to select a parameter (display: 'set'),
- UP to modify (increase) the value of the parameter. To scroll the values faster press UP together with DOWN,
- DOWN to modify (decrease) the value of the parameter. To scroll the values faster press DOWN together with UP,
- ENTER to save the new value and return to the list of parameters, or ESC to return to the list without saving the new value,

Press ESC to return to the main screen.

7.2 Basic parameters

Parameter		UOM	range	def	notes
P0	maximum production (also see paragraph 6.5)	%	20 to 100	100	
P1	humidification differential	rH, °C	2.0, ..., 19.9	5.0	
P2	Probe maximum threshold	rH, °C	0...100	80	
P3	Probe minimum threshold	rH, °C	0...100	20	
st	outlet set point	rH, °C	20...100	50	
A0	operating mode 0= ON/OFF control, 1= proportional, 2= room probe, 3= temperature probe	-	0 to 3	1	
A1	unit of measure: 0= kg/h; 1= lb/h	-	0 to 1	0	
A2	type of production request signal (the parameter can be displayed when A0=1) 1=0 to 10 V; 2= 2 to 10 V; 3= 4 to 20 mA; 4= 4 to 20 mA; 5= NTC	-	1...5	1	
A3	room probe minimum value	rH, °C	-99..212	0	accessible only in mode "control" (A0=2)
A4	room probe maximum value	rH, °C	0...100	0	
A5	probe offset control, for non-CAREL probes	rH, °C	-100...+100	0	
A6	Relay M14 activation delay for signalling presence of steam production request / activating external fan	s	0 to 300	0	Visible only if function activated (parameter b1, see par 11.6)
A7	Relay M14 deactivation delay for signalling presence of steam production request / deactivating external fan	s	0 to 300	180	Visible only if function activated (parameter b1, see par 11.6)
C0	value normally displayed 1= input/control signal; 2= steam prod.; 3= hour counter; 4= conductivity; 5= current	-	1 to 5	2	

7.3 Advanced parameters

Parameter		UOM	range	def	notes
b1	optional functions (see paragraph 11.6)	-	0 to 127	0	
b2	delay time when shutting down	s	0 to 120	0	
b4	Override conductivity of the water 0= automatic measurement	µS/cm	0 to 1250	0	Visibile solo se attivata la funzione (parametro b1, vedi par 11.6)
b5	conductivity pre-alarm threshold (*)	µS/cm	0 to 2000	1500	
b6	conductivity alarm threshold (*)	µS/cm	0 to 2000	2000	
b7	foam threshold setting 0= no foam detection; 1= max. foam detection sensitivity; 100= min. foam detection sensitivity	%	0 to 100	50	
b8	conductivity setting inside the cylinder in steady operation compared to rated value	%	50 to 200	100	
b9	duration of the drain to dilute cycle	%	50 to 200	100	
bb	cylinder maintenance limit time (in hours) 0= the cylinder life alarm "Cy" and maintenance required alarm "Mn" are not shown (*)	h	0 to 4000	1500	
bE	time limit between two periodical drain cycles (available only if periodical drain is enabled, b1 = 64)	h	1 to 240	24	
bf	days delay for drain due to inactivity (not available if the drain due to inactivity has been disabled, 8 set for b1)	days	1 to 199	3	

(*) after 999 the display shows **1000** to indicate 1000 (only three digits plus point - between the first and the second digit- are displayed).

7.4 Serial connection parameters





Parameter		UOM	range	def	notes
C3	serial address	-	1 to 199	1	
C4	baud rate: 0= 9,600; 1= 19,200	-	0 to 1	0	
C5	supervisor: frame (character bits, parity, stop bits) 0=8,N,2 1=8,N,1 2=8,E,2 3=8,E,1 4=8,O,2 5=8,O,1 6=7,N,2 7=7,N,1 8=7,E,2 9=7,E,1 10=7,O,2 11=7,O,1		0 to 11	0	
C6	serial response transmission delay	ms	0 to 199	0	
C8	maximum time with no data (sent to controller) over RS485 to generate stop production and "SU" alarm	0.1s (es: 50=5s)	0...300.0	5.0	see variable "I" 62





7.5 Read-only parameters

Parameter		UOM	range	def	notes
d1	display signal measured by external controller (only if A0=1)	%	0.0 to 199	-	
d3	display steam production (instant value)	kg/h	0.0 to 199	-	
d5	conductivity of the supply water (*)	µS/cm	0 to 1500	-	
d6	current	A	0.0 to 199	-	
d7	display maximum production (related to P0 set range)	kg/h	0.0 to 199	-	
d9	rated steam production	kg/h	0.0 to 199	-	
da	percentage hour counter	h			
db	real hour counter	h			

Tab. 7.d(*) after 999 the display shows **1000** to indicate 1000 (only three digits plus point - between the first and the second digit- are displayed).

8. ALARMS

code display and symbol	code var. I89	meaning	causes	solution	reset (press)	alarm relay activation	effect	red LED signal on board (*) (if terminal not connected)	
E0	-	1008Hex	calibration parameter software verification error	internal memory error	if the problem persists, contact the CAREL service center	--	yes	humidification stopped	3 fast flashes
E1	-	1004Hex	parameter configuration error	error in the parameters user	if the problem persists, contact the CAREL service center	--	yes	humidification stopped	4 fast flashes
EH	A	1010Hex	excess current	over-current at the electrodes; probable electrode malfunction or water conductivity temporarily too high (especially when starting after a short stop)	1. check the operation of the drain pump 2. check the seal of the fill electrovalve when not energised 3. drain part of the water and re-start	AUTO	yes	humidification stopped	2 fast flashes
EP		1020Hex	no production	excessive reduction in production, or cylinder completely depleted or water	Perform maintenance on the cylinder	ESC	yes	humidification stopped	4 slow flashes
CY		3001Hex	cylinder life pre-alarm	the cylinder full limit of 1500 h (default)	perform maintenance and/or replace the cylinder	ESC (the alarm is reactivated after 50 hrs)	no	signal only	7 fast flashes
EF		2004Hex	no water		Check: water supply and fill valve; whether the manual drain is open; blockage of the filter on the fill solenoid valve; whether there is excessive backpressure in steam outlet, preventing the flow of water into the cylinder by gravity; that the steam outlet hose is not choked or that there are no pockets of condensate; that the power cables are connected to the cylinder	automatic (after 10 minute waiting time)	yes (in 10 minute waiting time)	humidification stopped for 10 minutes only	3 slow flashes
Ed		2008Hex	failed drain		check the drain pump and drain connection	ESC	yes	humidification stopped	5 slow flashes
CP		3004Hex	cylinder being depleted signal		cylinder life ending, perform maintenance and/or replace the cylinder	ESC	no	signal only	6 slow flashes
CL		3008Hex	cylinder depleted signal		cylinder life ended, perform maintenance and/or replace the cylinder	--	no	signal only	10 slow flashes

code display and symbol	code var. I89	meaning	causes	solution	reset (press)	alarm relay activation	effect	red LED signal on board (*) (if terminal not connected)
EA 	3002Hex	foam	excessive foam in the cylinder during boiling. the formation of foam is generally due to the presence of surfactants in the water (lubricants, solvents, detergents, water treatment agents, softeners) or an excessive concentration of dissolved salts.	1. drain the water supply lines 2. clean the cylinder 3. check for the presence of softeners (in this case, use another type of water or reduce the softening)	ESC	no	signal only	9 slow flashes
E2	3010Hex	memory backup fails	internal memory error	if the problem persists, contact the CAREL service center	--	no	signal only	6 fast flashes
Mn 	1001Hex	end of cylinder life		the cylinder has exceeded the limit of 2000 hours, replace the cylinder	reset hour counter	yes	humidification stopped	8 fast flashes
EU 	2001Hex	cylinder full	excessive water level when unit producing steam	with the machine off: 1. check for any leaks from the fill electrovalve or the condensate return pipe 2. check that the level sensors are clean total shut-down pipe 2. check that the level sensors are clean total shut-down	--	no	signal only	8 slow flashes
EC 	1002Hex	high conductivity	high supply water conductivity	1. check water conductivity 2. if the problem persists, change the source of supply water or install a suitable treatment system (demineralisation, even partial). N.B.: the problem will not be resolved by softening the supply water.	AUTO	no (b5) yes (b6)	signal only humid. stopped	5 fast flashes
E3	2002Hex	failed connection of modulating signal		check the reference signal in 4 to 20 mA or 2 to 10V mode or NTC	ESC	yes	humidification stopped	7 slow flashes
E_	2020Hex	low room humidity (low temp. when using temperature probe)		check the probe operation and the limit set on parameter P2	AUTO	yes	humidification stopped	9 fast flashes
E-	2010Hex	high room humidity (high temp. when using temperature probe)		check the probe operation and the limit set on parameter P3	AUTO	yes	humidification stopped	10 fast flashes
SU	2040Hex	serial disconnected			AUTO			2 slow flashes
Pre/Cln	-	cylinder cleaning started signal			--	--	--	none
dr	-	cylinder drain activated			--	--	--	none
dr /TOT	-	complete drain due to inactivity			--	--	--	(both codes alternate on display)
AF 		antifoam active			--	--	--	none

Press ESC once to mute the buzzer, press ESC a second time to reset the alarm.

(*) Quick flash: 0.2 seconds ON and 0.2 seconds OFF

Slow flash: 1 second ON and 1 second OFF

9. MAINTENANCE AND SPARE PART

9.1 Spare parts for models UE005 to UE015

Key to Figs. 9a & 9.b:

- 1 fill tank
- 2 internal tubing kit
- 3 fill solenoid valve kit
- 4 cylinder
- 5 manifold with drain pump
- 6 plastic base
- 7 plastic humidifier top
- 8 TAM (transformer for measuring the current)
- 9 transformer
- 10 contactor
- 11 fuse holder F1 F2
- 12 electronic controller
- 13 power terminals
- 14 fuse holder F3
- 15 switch
- 16 terminal with display
- M Manifold

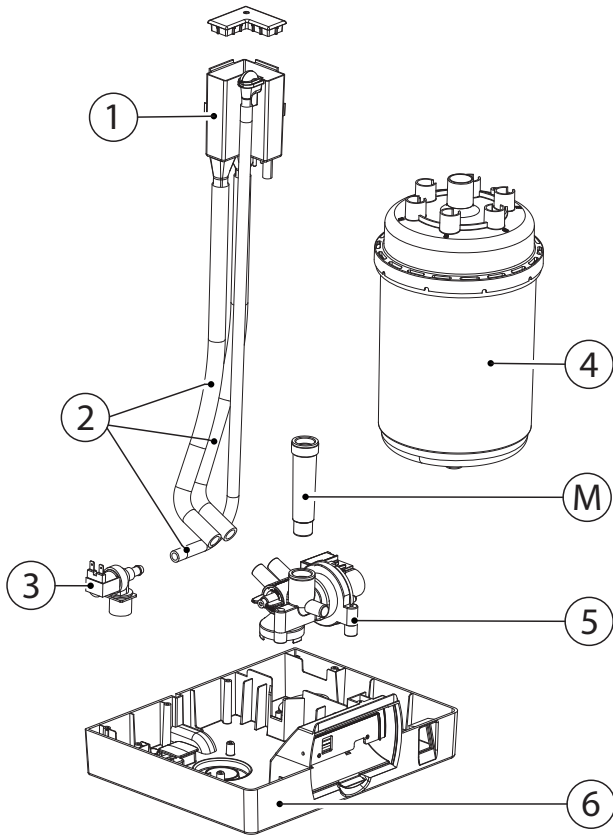

Fig. 9.a

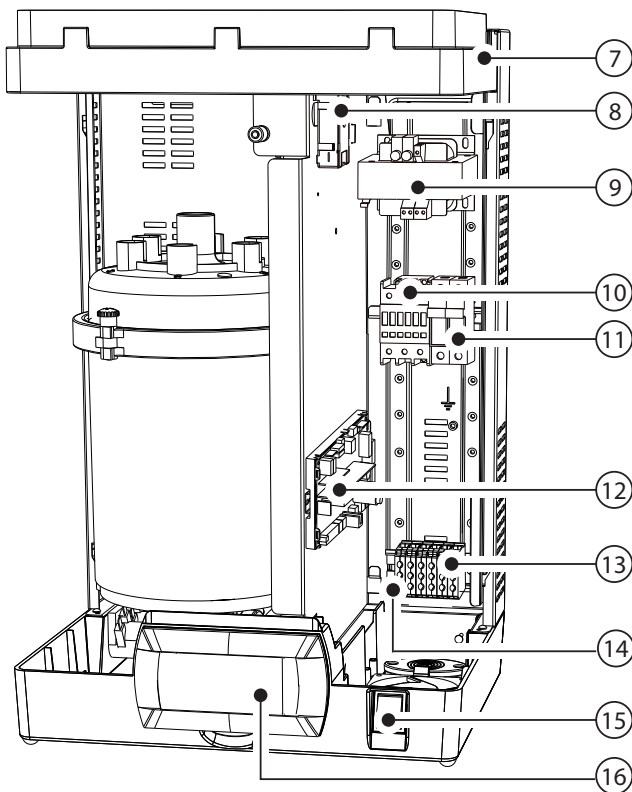

Fig. 9.b

Table of water circuit, electrical and electronic spare parts, UE005 to 015

	spare part code				position	figure
	UE005	UE008	UE010	UE015		
Water circuit						
Fill tank + conductivity meter		UEKVASC000			1	9.a
Fill solenoid valve kit	KITVC10006		KITVC10011		3	9.a
Internal tubing kit		UEKT10000M			2	9.a
Plastic humidifier base		UEKBOTTOM0			6	9.a
Plastic humidifier top		UEKTOP0000			7	9.b
Assembled f/d manifold+ pump		UEKDRAIN03			5	9.a
Manifold to increase cylinder height		UEKMANIF00			M	9.a
Electrical and electronics						
Display terminal		HCTLEYWCw0 ⁽¹⁾			16	9.b
TAM (current transformer)		UEKTAM0000			8	9.b
Contactora	UEKCONT100		UEKCONT200		10	9.b
Power transformer: 230-400/24 V		UEKTR30000			9	9.b
Electronic controller ⁽¹⁾		UEYxxvCz0i ⁽²⁾			13	9.b
Fuse carrier (F1,F2)		URKFH10000			11	9.b
Fuse carrier (F3)		UEKFH10000			14	9.b
F1 - F2 230 to 400 Vac power fuses		UEKFUSE100			-	see wiring diagrams
F3 Pump fuse		UEKFUSE900			-	see wiring diagrams
F4 Transformer secondary fuse		UEKFUSE400			-	see wiring diagrams
Connection cable between terminal and electronic controller		S90CONN002			-	

Tab. 9.a

- (1) when ordering, as well as the controller code specify the complete code and serial number of the humidifier.
- (2) xx: kg/h (01,.....65)
v: power supply (D=230V 1ph, L=400V 3ph, etc)
z: match digit board (8th code number of the card)
i: 0 single package / 1 multiple package
- (3) w: match digit terminal (9th code number of the terminal)

Table of spare part codes, three-phase cylinders UE005 to 015, electrode and gasket kit

Model		UE005	UE008	UE010	UE015
STANDARD openable cylinders	400 VAC 3~, conductivity 350 to 750 µS/cm	BLCT2C00W2	BLCT2C00W2	BLCT3C00W2	BLCT3C00W2
SPECIAL openable cylinders	400 VAC 3~, conductivity 75 to 350 µS/cm	BLCT2B00W2	BLCT2B00W2	BLCT3B00W2	BLCT3B00W2
	400 VAC 3~, conductivity 750 to 1250 µS/cm	BLCT2D00W2	BLCT2D00W2	BLCT3D00W2	BLCT3D00W2
SPECIAL not openable cylinders	400 VAC 3~, conductivity 75 to 350 µS/cm	BL0T2B00H2	BL0T2B00H2	BL0T3B00H2	BL0T3B00H2
	400 VAC 3~, conductivity 350 to 750 µS/cm	BL0T2C00H2	BL0T2C00H2	BL0T3C00H2	BL0T3C00H2
Electrode and gasket kit	400 VAC 3~, conductivity 750 to 1250 µS/cm	BL0T2D00H2	BL0T2D00H2	BL0T3D00H2	BL0T3D00H2
	Electrode kit 400 Vac 3~, 75 - 350 µS/cm	KITBLCT2B2	KITBLCT2B2	KITBLCT3B2	KITBLCT3B2
	Electrode kit 400 Vac 3~, 350 - 750 µS/cm	KITBLCT2C2	KITBLCT2C2	KITBLCT3C2	KITBLCT3C2
	Electrode kit 400 Vac 3~, 750 - 1250 µS/cm	KITBLCT2D2	KITBLCT2D2	KITBLCT3D2	KITBLCT3D2
Filter gasket kit		KITBLC2FG0	KITBLC2FG0	KITBLC3FG0	KITBLC3FG0

Tab. 9.b

9.2 Spare parts for models UE025 to UE065

Key:

- 1 drain circuit
- 2 fill solenoid valve kit
- 3 internal tubing kit
- 4 conductivity meter
- 5 drain pump kit
- 6 manifold
- 7 drain pump hose
- 8 cylinder
- 9 TAM (transformer for measuring the current)
- 10 contactor
- 11 transformer
- 12 pump control relay
- 13 fuse carrier
- 14 electronic controller
- 15 power terminals
- 16 cable clamp
- 17 switch
- 18 terminal with liquid crystal display (fitted on the cover of the electrical compartment)

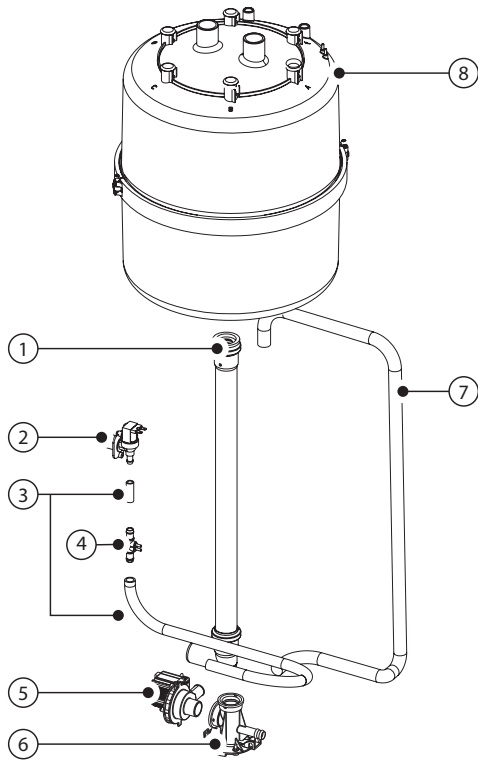

Fig. 9.c

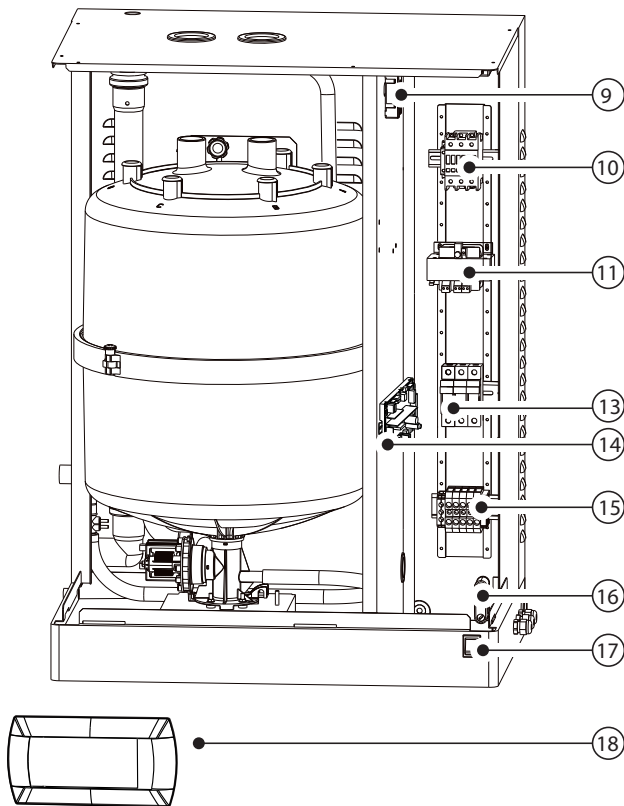

Fig. 9.d

Table of water circuit, electrical and electronic spare parts, UE025 to UE065

description	spare part code				pos.	figure
	UE025	UE035	UE045	UE065		
Water circuit						
Drain pump hose		UEKDH00000			7	9.c
Manifold		UEKCOLL000			6	9.c
Drain pump kit		KITPSE0000			5	9.c
Internal tubing kit		UEKT10000L		UEKT1000XL	3	9.c
Double check valve kit		FWHDCV0000			-	-
Conductivity meter kit		KITCN00000			4	9.c
Fill solenoid valve kit		KITVC10058		KITVC10070	2	9.c
Drain circuit		UEKDC00000		UEKDC10000	1	9.c
Electrical and electronics						
Display terminal		HCTLEYFCw0 ⁽³⁾			18	9.d
TAM (current transformer)		UEKTAM0000			9	9.d
Contactors	UEKCONT200	URKCONT400		URKCONT300	10	-
Power transformer: 230/400-24V		UEKTR30000			11	9.d
Electronic controller		UEYxxvCz0j ⁽²⁾			14	9.d
Fuse carrier		URKFH20000			13	9.d
Pump control relay		UEKRD00000			-	-
F1 - F2 230 to 400Vac power fuses	UEKFUSE100	UEKFUSE100	UEKFUSE100	UEKFUSE100	-	see wiring diagrams
F3 Pump fuse		URKFUSE300			-	see wiring diagrams
F4 Transformer secondary fuse		UEKFUSE400			-	see wiring diagrams
Connection cable between terminal and electronic controller		S90CONN002			-	-

Tab. 9.c

- (1) when ordering, as well as the controller code specify the complete code and serial number of the humidifier.
(2) xx: kg/h (01.....65) - v: power supply (K=230V 3ph, L=400V 3ph, etc.)
z: match digit board (8th code number of the card) - i: 0 single package / 1 multiple package
(3) w: match digit terminal (9th code number of the terminal)

Table of spare parts for standard and special cylinders UE025 to UE065

Description		UE025	UE035	UE045	UE065
STANDARD openable cylinders	400V 3ph cylinder, conductivity 350 to 1250 µS/cm	BLCT4D00W2	BLCT4D00W2	BLCT4C00W2	BLCT5C00W0
SPECIAL openable cylinders	400V 3ph cylinder, conductivity 75 to 350 µS/cm	BLCT4C00W2	BLCT4C00W2	BLCT4B00W2	BLCT5B00W0
SPECIAL not openable cylinders	400V 3ph cylinder, conductivity 75 to 350 µS/cm	BL0T4C00H2	BL0T4C00H2	BL0T4B00H2	BL0T5B00H0
	400V 3ph cylinder, conductivity 350 to 1250 µS/cm	BL0T4D00H2	BL0T4D00H2	BL0T4C00H2	BL0T5C00H0
Electrode and gasket kit	400V 3ph cylinder, conductivity 75 to 350 µS/cm	KITBLCT4C2	KITBLCT4C2	KITBLCT4B2	KITBLCT5B0
	400V 3ph cylinder, conductivity 350 to 1250 µS/cm	KITBLCT4D2	KITBLCT4D2	KITBLCT4C2	KITBLCT5C0
Gasket and filter kit		KITBLC4FG0	KITBLC4FG0	KITBLC4FG0	KITBLC5FG0

Tab. 9.d

9.3 Cleaning and maintenance of the cylinder

Replacement



Important: he cylinder must be only be replaced by qualified personnel, and with the humidifier unplugged from the power supply.

In normal conditions, the **disposable cylinders should be replaced after one year** (or 2500 hours of operation, if cleaned periodically), while the **openable cylinders last 5 years** (or 10,000 hours of operation, if cleaned periodically). They must be replaced immediately – even before the specified intervals – if any anomalies occur. For example, when the lime scale inside the cylinder prevents the correct flow of electric current.

Replacement procedure:

- empty all the water (see chap. 6);
- turn off the humidifier (switch "0"), and open the mains disconnect switch on the power supply (safety procedure);
- wait for the humidifier and the cylinder to cool down;
- remove the front cover;
- disconnect the electrical cables from the cylinder;
- release the cylinder from the locking device and lift it to remove it;
- insert the new cylinder (make sure that the model and the power supply of the new cylinder correspond to the rated data);
- fasten the cylinder;
- reconnect the electrical cables to the cylinder;
- replace the front cover;
- switch on the humidifier;
- reset cylinder operating hour counter (see parameters da , chap. 7);
- Activate the wash new cylinder procedure, pressing ENTER + DOWN for 5 seconds

Periodical checks

- **After one hour** of operation: check for any significant water leaks.
- **Every 15 days** or no more than 300 operating hours: check operation, the absence of significant water leaks, the general conditions of the casing. Check that during operation there are no arcs or sparks between the electrodes.
- **Every 3 months** or no more than 1000 operating hours:

- disposable cylinders: check operation, the absence of significant water leaks and if necessary replace the cylinder;
- openable cylinders: if there are significantly blackened areas, check the deposits on the electrodes and clean them, using the specific electrode and gasket kit.
- **Every year** or no more than 2500 operating hours:
 - disposable cylinders: replace;
 - openable cylinders: if there are significantly blackened areas, check the deposits on the electrodes and clean them, using the specific electrode and gasket kit.
- **After 5 years** or no more than 10,000 operating hours: replace the openable cylinder.

After extended operation, or when using water rich in salts, the solid deposits that naturally form on the electrodes may grow until attaching to the inside wall of the cylinder. If these deposits are conductive the heat generated may overheat the plastic until it melts, with the risk of very hot water being released.

Important: In the event of water leaks, disconnect the power supply from the humidifier as the water may conduct electricity.

9.4 Mechanically draining the water in the cylinder

Drain due to gravity without activating the humidifier, recommended if:

- humidifier decommissioned;
- to empty the cylinder without switching the humidifier on.

Mechanical drain:

- make sure that the humidifier is not powered;
- remove the cover;
- activate the mechanical device under the cylinder (see part A, Fig. 9.e).

Models UE005 to UE015

Models UE025 to UE065

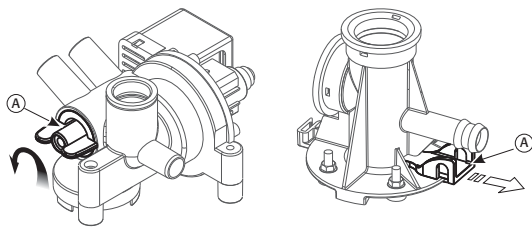

Fig. 9.e

9.5 Cylinder connection, three-phase models UE025 to UE065

production (kg/h)	conductivity (µS/cm)	power supply (V)
		400
25	75/350 µS/cm	B
	350/1250 µS/cm	B
35	75/350 µS/cm	B
	350/1250 µS/cm	B
45	75/350 µS/cm	A
	350/1250 µS/cm	B
65	75/350 µS/cm	A
	350/1250 µS/cm	B

Tab. 9.e

The cable ends must be tightened with the top nut to 3 Newton · m. (units with BL*T5* cylinder only)

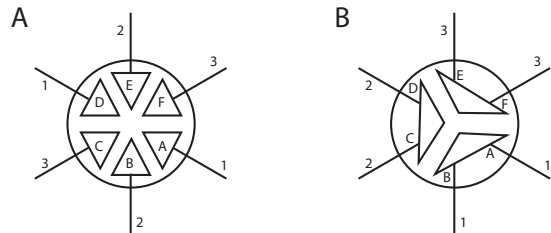

Fig. 9.f

9.6 Cleaning and maintenance of the other components

- when cleaning plastic components do not use detergents or solvents;
- scale can be removed using a solution of 20% acetic acid and then rinsing with water.

Maintenance checks on other components:

- fill solenoid valve. After having disconnected the cables and the tubing, remove the solenoid valve and make sure the inlet filter is clean; if necessary, clean with water and a soft brush;
- manifold with drain pump. Check that there are no solid residues in the cylinder attachment, remove any impurities. Check that the gasket (o-ring) is not damaged or cracked, replace if necessary. Check that there are no solid residues in the drain hose;
- drain pump. Disconnect the power supply, remove the pump and clean any impurities. Clean the tank from any deposits and check that the water flows freely from the tank to the drain (corresponding to the drain pump);
- fill tank. Check that there are no obstructions or solid particles and that the conductivity measuring electrodes are clean, remove any impurities and rinse;
- internal tubing kit. Check that the pipes and hoses are free and clear of impurities, remove any impurities and rinse.

Important: after having replaced or checked the water circuit, make sure that the connections are tight. Restart the unit and run a number of fill and drain cycles (from 2 to 4), after which, applying the safety procedure, check for any water leaks.

Fuses in the auxiliary circuits

Fuses	UE005 to 015	UE 025 to 065
F1 & F2	1 A fast-blow, 10.3x38	1 A fast-blow, 10.3x38
F3	2 A fast-blow, 5x20 ceramic	1 A fast-blow, 10.3x38
F4	4 A T slow-blow 5x20 ceramic	4 A T slow-blow 5x20 ceramic

Tab. 9.f

10. WIRING DIAGRAMS

10.1 Diagram of three-phase models UE005 to UE015

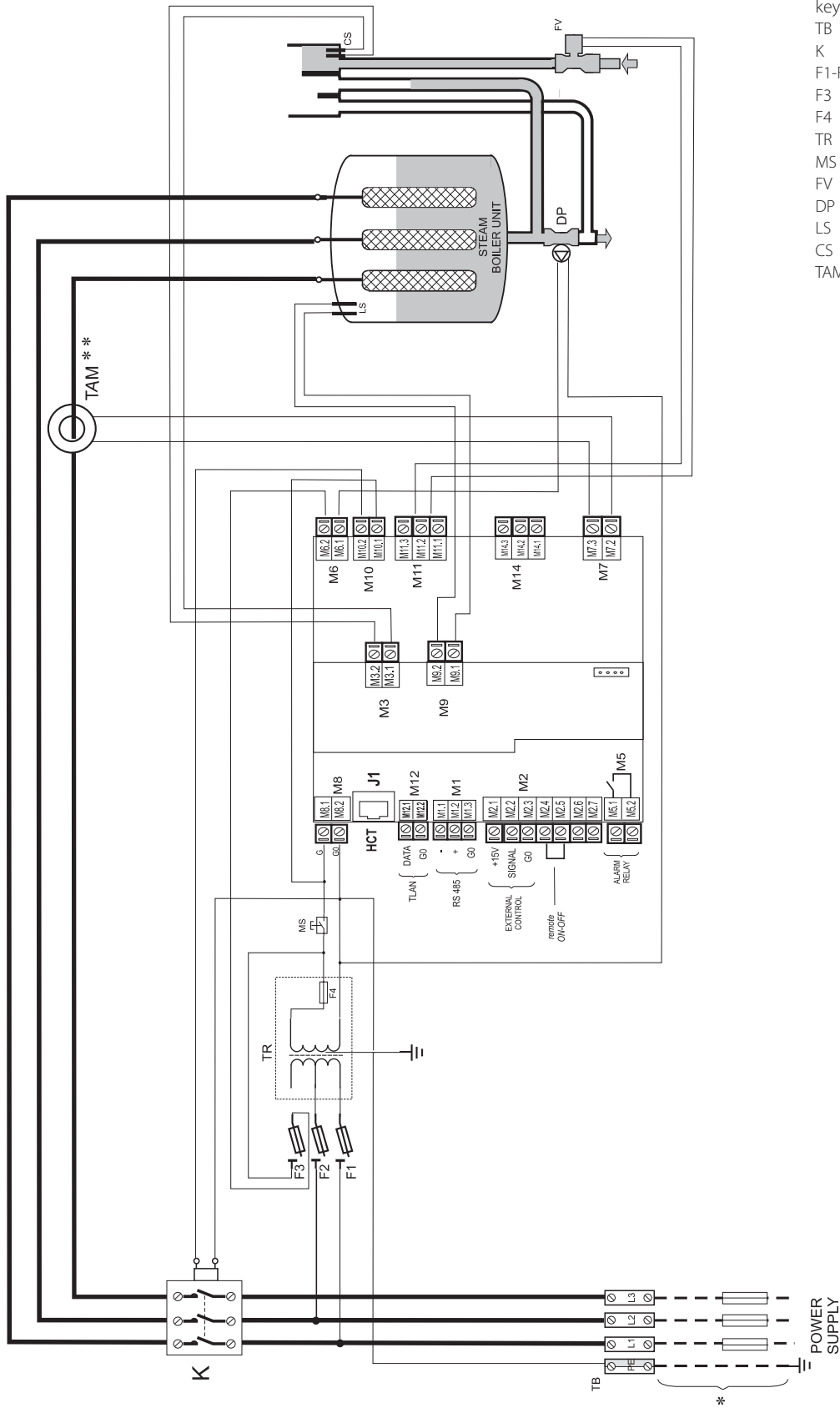
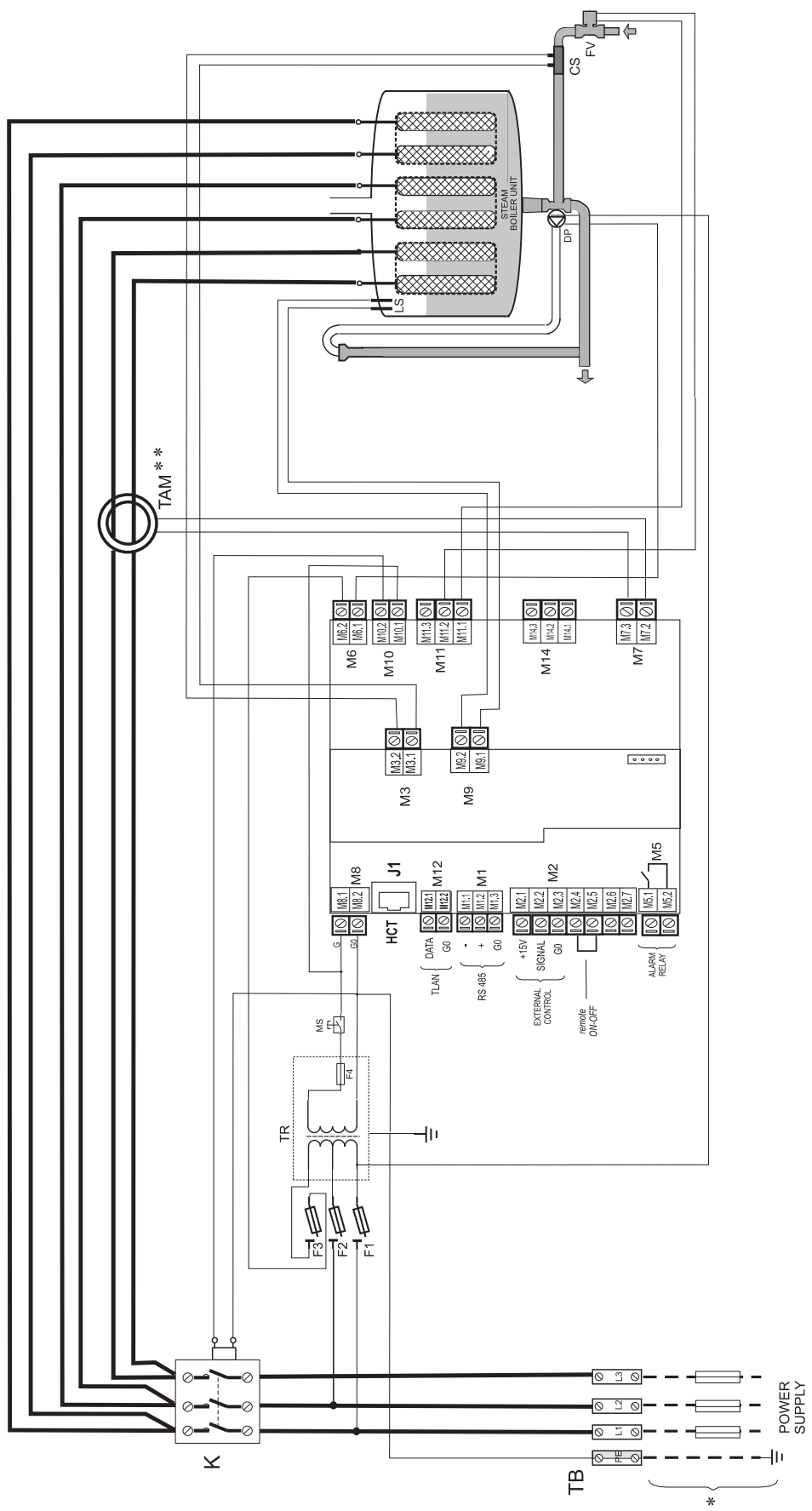

Fig. 10.a

(**) Important: for the TAM configuration and connection see par. 11.1

10.2 Diagram of three-phase models UE025 to UE065



- key:
- TB terminal block
 - K contactor
 - F1-F2 primary fuses
 - F3 fuse protection drain pump
 - F4 secondary fuses
 - TR transformer
 - MS manual switch
 - FV fill valve
 - DP drain pump
 - LS high level electrodes
 - CS conductimetric
 - TAM external TAM

Fig. 10.b

(**) Important: for the TAM configuration and connection see par. 11.1

11. GENERAL FEATURES AND MODELS

11.1 humiSteam models and electrical specifications

The following table lists the electrical data relating to the power supply of the various models and the specifications of each. Note that some models may be powered at different voltages, obviously with different power input and steam production.

model	steam production ^(2;4) (kg/h)	power ⁽²⁾ (kW)	power supply			rated specifications TAM configuration ⁽⁵⁾		cable ⁽³⁾ (mm ²)	line fuses ⁽³⁾ (A / type)	wiring diagram (Fig.)
			code	voltage ⁽¹⁾ (V - type)	current ⁽²⁾ (A)					
UE005	5.0	3.7	L	400 - 3~	5.4	11.a	100	1.5	10 A / fast-blow	10.b
UE008	8.0	6.0	L	400 - 3~	8.7	11.a	100	2.5	16 A / fast-blow	10.b
UE010	10.0	7.5	L	400 - 3~	10.8	11.d	300	2.5	16 A / fast-blow	10.b
UE015	15.0	11.2	L	400 - 3~	16.2	11.a	300	6.0	32 A / fast-blow	10.b
UE025	25	18.7	L	400 - 3~	27.1	11.c	500	16	50 A / fast-blow	10.c
UE035	35	26.2	L	400 - 3~	37.9	11.b	500	16	60 A / fast-blow	10.c
UE045	45	33.7	L	400 - 3~	48.7	11.c	700	25	80 A / fast-blow	10.c
UE065	65	48.7	L	400 - 3~	70.4	11.c	700	35	100A / fast-blow	10.c

Tab. 11.a

tolerance allowed on the rated mains voltage: -15%, +10%;

⁽²⁾ tolerance on the rated values: +5%, -10% (EN 60335-1);

⁽³⁾ recommended values refer to laying PVC or rubber cables in closed conduits, 20 m (65.6 feet) long; the standards in force must however be observed,

⁽⁴⁾ rated max instant steam production: the average steam production may be affected by external factors, such as: ambient temperature, water quality, steam distribution system;

⁽⁵⁾ refer to the wiring diagrams to verify

the data are not absolute and if these differ from local standards, the latter must prevail.

TAM configurations and connections (transformer for measuring the current)

! Important: the configurations and connections are already made by CAREL, and no changes are required. The following diagrams represent possible connection modes and may be useful in the event of serious electrical malfunctions on the humidifier.

All operations must only be performed by qualified personnel, improper use may cause serious damage.

one cable turn

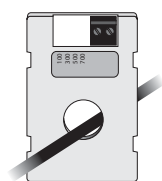

Fig. 11.a

one turn of the two cables of the same phase

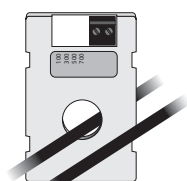

Fig. 11.b

two cable turns of the same phase

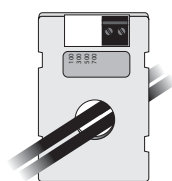

Fig. 11.c

one cable in "double turn" mode

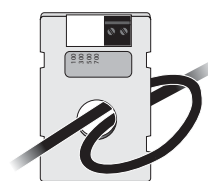

Fig. 11.d

three cable turns of the same phase

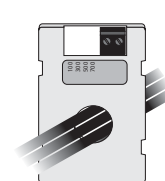

Fig. 11.e

! Important: to avoid interference, separate the power cables from the probe cables.

11.2 Technical specifications

technical specifications	UEY models							
	UE005	UE008	UE010	UE015	UE025	UE035	UE045	UE065
steam								
dia. mm (in)	30 (1.2)				1x40 (1x1.6)			4x40 (2x1.6)
outlet pressure limits Pa (PSI)	-900/1300 (-0.131/0.188)				-900/2000 (-0.131/0.290)			
supply water								
connection	3/4" G							
temperature limits °C (°F)	1 to 40 (33.8 to 104)							
pressure limits (MPa)	0.1 to 0.8 (1 to 8 bars)							
hardness limits (°fH)	≤ 40							
instant flow-rate (l/min)	0.6		1.1		5.85 (7 for UE045 A 230Vac)		7	
conductivity range (µS/cm)	75 to 1250							
cdrain water								
connection dia. mm (in)	40 (1.6)							
typical temperature °C (°F)	≤100 (212)							
instant flow-rate (l/min)	7				22.5			
environmental conditions								
ambient operating temp. °C (°F)	1 to 40 (33.8 to 104)							
ambient operating humidity (% rH)	10 to 60							
storage temperature °C (°F)	-10 to 70 (14 to 158)							
storage humidity (% rH)	5 to 95							
index of protection	IP20							
electronic controller								
Y basic	UEY							
auxiliary voltage/frequency (V - Hz)	24 / 50							
maximum auxiliary power (VA)	90							
probe inputs (general features)	can be selected for the following signals: 0 to 10 Vdc, 2 to 10 Vdc, 0 to 20 mA, 4 to 20 mA input impedance: 20 kΩ with: 0 to 10 Vdc, 2 to 10 Vdc signals 100 Ω with: 0 to 20 mA, 4 to 20 mA signals							
active probe power supply (general features)	15 Vdc. 100 mA, protected against short-circuits +1 Vdc with 135 Ω load							
alarm relay outputs (general features)	250 V 5 A (2 A) - type of action-microswitching 1C							
remote enable input (general features)	cvoltage-free contact; max. resistance 100 Ω; Vmax= 5 Vdc; Imax= 5 mA							
output								
instant steam production ⁽¹⁾ kg/h (lb/h)	5.0 (11)	8.0 (17.6)	10.0 (22)	15.0 (33)	25 (55.1)	35 (77.2)	45 (99.2)	65 (143.3)
power input at rated voltage (kW)	3.75	6.0	7.5	11.25	18.75	26.25	33.75	48.75

Tab. 11.b

⁽¹⁾= the average steam production is affected by factors such as: ambient temperature, water quality, steam distribution system

11.3 Models of steam hoses

code	UEY models							
	UE005Y	UE008Y	UE010Y	UE015Y	UE025Y	UE035Y	UE045Y	UE065Y
steam outlet dia. mm (in)	30 (1.2")	30 (1.2")	30 (1.2")	30 (1.2")	40 (1.6")	40 (1.6")	40 (1.6")	2x40 (2x1.6")
max. capacity kg/h (lb/h)	5 (11)	8 (17.6)	10 (22)	15 (33)	25 (55.1)	35 (77.2)	45 (99.2)	65 (143.3)
CAREL steam hoses								
code	ID mm (")							
1312365AXX	30 (1.2")	√	√	√	√	-	-	-
1312367AXX	40 (1.6")	-	-	-	-	√	√	√

Tab. 11.c

11.4 Models of concentrated jet steam distributors

			UEY models							
code			UE005Y	UE008Y	UE010Y	UE015Y	UE025Y	UE035Y	UE045Y	UE065Y
steam outlet dia.	mm (in)		30 (1.2")	30 (1.2")	30 (1.2")	30 (1.2")	40 (1.6")	40 (1.6")	40 (1.6")	2x40 (2x1.6")
max. capacity	kg/h (lb/h)		5 (11)	8 (17.6)	10 (22)	15 (33)	25 (55.1)	35 (77.2)	45 (99.2)	65 (143.3)

CAREL distributors concentrated jet										
code	steam inlet dia. mm (in)	max. capacity kg/h (lb/h)								
SDPOEM0022	30 (1.2")	18 (39.7)	1	1	1	1	-	-	-	-
SDPOEM0000	30 (1.6")	18 (39.7) (with 30mm/1.6" hole)	1	1	1	1	(2)*	(2)*	(4)**	(4)**

Tab. 11.d

- 1 = the humidifier is connected to just one distributor
- (2) = the humidifier is connected to two distributors (using the "Y" kit: UEKY000000)
- 2 = the humidifier is fitted with two outlets and can be connected to two distributors
- (4) = the humidifier is fitted with two outlets and can be connected to up to four distributors (using two "Y" kits)
- * = use CAREL "Y" kit code UEKY000000 (40 mm/1.6" inlet and 2 x 30 mm/1.2" outlets)
- ** = use CAREL "Y" kit code UEKY000000 (40 mm/1.6" inlet and 2 x 30 mm/1.2" outlets)

11.5 Models of linear distributors and typical installations

				UEY models								
code				UE005Y	UE008Y	UE010Y	UE015Y	UE025Y	UE035Y	UE045Y	UE045Y (230V)	UE065Y
steam outlet dia.	mm (in)			30 (1.2")	30 (1.2")	30 (1.2")	30 (1.2")	40 (1.6")	40 (1.6")	40 (1.6")	2x40 (2x1.6")	2x40 (2x1.6")
max. capacity	kg/h (lb/h)			5 (11)	8 (17.6)	10 (22)	15 (33)	25 (55.1)	35 (77.2)	45 (99.2)	45 (99.2)	65 (143.3)

CAREL DP型线性蒸汽分配器												
code	steam inlet dia. mm (in)	max. capacity kg/h (lb/h)	length mm (in)									
DP035D30R0	30 (1.2")	5 (11)	343 (13.5)	1	-	-	-	-	-	-	-	-
DP045D30R0	30 (1.2")	8 (17.6)	427 (16.8)	1	1	-	-	-	-	-	-	-
DP060D30R0	30 (1.2")	12 (26.5)	596 (23.5)	1	1	1	-	-	-	-	-	-
DP085D30R0	30 (1.2")	18 (39.7)	850 (33.5)	1	1	1	1	(2)*	(2)*	-	-	-
DP105D30R0	30 (1.2")	18 (39.7)	1048 (41.3)	1	1	1	1	(2)*	(2)*	-	-	-
DP125D30R0	30 (1.2")	18 (39.7)	1245 (49)	1	1	1	1	(2)*	(2)*	-	-	-
DP165D30R0	30 (1.2")	18 (39.7)	1636 (64.4)	-	-	1	1	(2)*	(2)*	-	-	-
DP085D40R0	40 (1.6")	25 (55.1)	834 (32.8)	-	-	-	-	1	(2)**	(2)**	2	(4)**
DP105D40R0	40 (1.6")	35 (77.2)	1015 (40)	-	-	-	-	1	1	(2)**	2	2
DP125D40R0	40 (1.6")	45 (99.2)	1022 (40.2)	-	-	-	-	1	1	1	1**	2
DP165D40R0	40 (1.6")	45 (99.2)	1636 (64.4)	-	-	-	-	-	1	1	1**	2
DP205D40R0	40 (1.6")	45 (99.2)	2025 (79.7)	-	-	-	-	-	1	1	1**	2

Tab. 11.e Tab. 11.e

- 1 = the humidifier is connected to just one distributor
- (2) = the humidifier is connected to two distributors (using the "Y" kit: UEKY000000) or UEKY000400??)
- 2 = the humidifier is fitted with two outlets and can be connected to two linear distributors
- (4) = the humidifier is fitted with two outlets and can be connected to up to four linear distributors (using two "Y" kits)
- * = use CAREL "Y" kit code UEKY000000 (40 mm/1.6" inlet and 2 x 30 mm/1.2" outlets)
- ** = use CAREL "Y" kit code UEKY404000 (40 mm/1.6" inlet and 2 x 30 mm/1.2" outlets)

For typical installations of the linear distributors, see Fig. 11.f on page 40

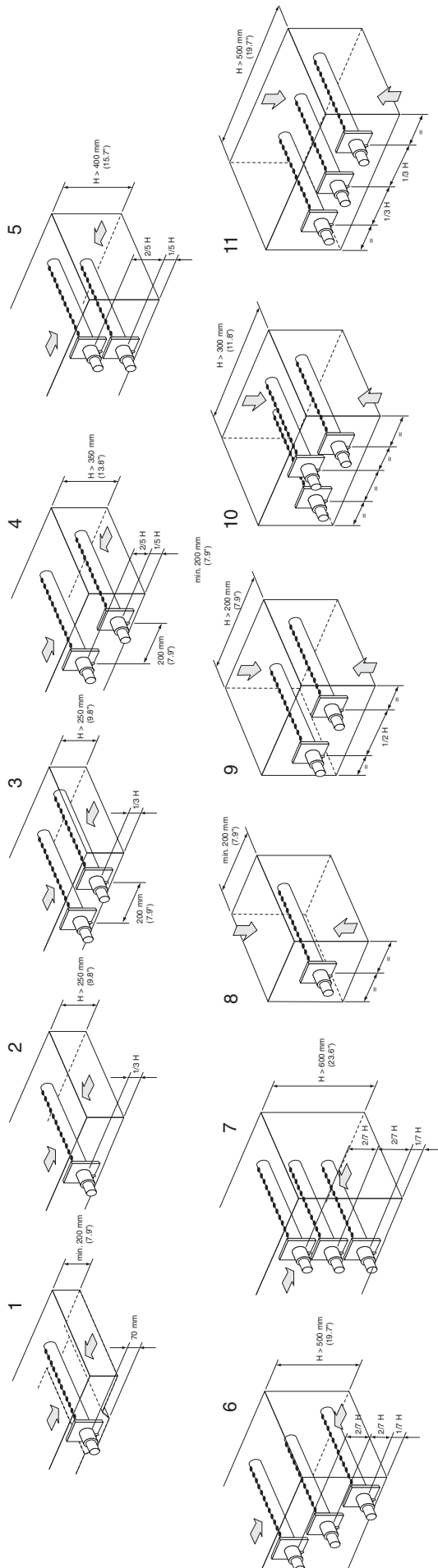

11.6 Table of parameter b1

b1	Alarm relay oscillation when "CY" alarm is on	Dilution drain with contactor	Drain if new request $\leq 2/3$ current request (contact open)	Total drain due to inactivity	Display of "CL" & "CP" alarms	Alarm relay activated if...	Periodical total drain	Enable management of steam request signal /external fan control relay M14
DEF.0	OFF	open	YES	ON, depending on bF	ON	alarms in progress	OFF	Disabled
1	ON	open	YES	ON, depending on bF	ON	alarms in progress	OFF	Disabled
2	OFF	closed	YES	ON, depending on bF	ON	alarms in progress	OFF	Disabled
3	ON	closed	YES	ON, depending on bF	ON	alarms in progress	OFF	Disabled
4	OFF	open	NO	ON, depending on bF	ON	alarms in progress	OFF	Disabled
5	ON	open	NO	ON, depending on bF	ON	alarms in progress	OFF	Disabled
6	OFF	closed	NO	ON, depending on bF	ON	alarms in progress	OFF	Disabled
7	ON	closed	NO	ON, depending on bF	ON	alarms in progress	OFF	Disabled
8	OFF	open	YES	OFF	ON	alarms in progress	OFF	Disabled
9	ON	open	YES	OFF	ON	alarms in progress	OFF	Disabled
10	OFF	closed	YES	OFF	ON	alarms in progress	OFF	Disabled
11	ON	closed	YES	OFF	ON	alarms in progress	OFF	Disabled
12	OFF	open	NO	OFF	ON	alarms in progress	OFF	Disabled
13	ON	open	NO	OFF	ON	alarms in progress	OFF	Disabled
14	OFF	closed	NO	OFF	ON	alarms in progress	OFF	Disabled
15	ON	closed	NO	OFF	ON	alarms in progress	OFF	Disabled
16	OFF	open	YES	ON, depending on bF	OFF	alarms in progress	OFF	Disabled
17	ON	open	YES	ON, depending on bF	OFF	alarms in progress	OFF	Disabled
18	OFF	closed	YES	ON, depending on bF	OFF	alarms in progress	OFF	Disabled
19	ON	closed	YES	ON, depending on bF	OFF	alarms in progress	OFF	Disabled
20	OFF	open	NO	ON, depending on bF	OFF	alarms in progress	OFF	Disabled
21	ON	open	NO	ON, depending on bF	OFF	alarms in progress	OFF	Disabled
22	OFF	closed	NO	ON, depending on bF	OFF	alarms in progress	OFF	Disabled
23	ON	closed	NO	ON, depending on bF	OFF	alarms in progress	OFF	Disabled
24	OFF	open	YES	OFF	OFF	alarms in progress	OFF	Disabled
25	ON	open	YES	OFF	OFF	alarms in progress	OFF	Disabled
26	OFF	closed	YES	OFF	OFF	alarms in progress	OFF	Disabled
27	ON	closed	YES	OFF	OFF	alarms in progress	OFF	Disabled
28	OFF	open	NO	OFF	OFF	alarms in progress	OFF	Disabled
29	ON	open	NO	OFF	OFF	alarms in progress	OFF	Disabled
30	OFF	closed	NO	OFF	OFF	alarms in progress	OFF	Disabled
31	ON	closed	NO	OFF	OFF	alarms in progress	OFF	Disabled
32	OFF	open	YES	ON, depending on bF	ON	no alarms in progress	OFF	Disabled
33	ON	open	YES	ON, depending on bF	ON	no alarms in progress	OFF	Disabled
34	OFF	closed	YES	ON, depending on bF	ON	no alarms in progress	OFF	Disabled
35	ON	closed	YES	ON, depending on bF	ON	no alarms in progress	OFF	Disabled
36	OFF	open	NO	ON, depending on bF	ON	no alarms in progress	OFF	Disabled
37	ON	open	NO	ON, depending on bF	ON	no alarms in progress	OFF	Disabled
38	OFF	closed	NO	ON, depending on bF	ON	no alarms in progress	OFF	Disabled
39	ON	closed	NO	ON, depending on bF	ON	no alarms in progress	OFF	Disabled
40	OFF	open	YES	OFF	ON	no alarms in progress	OFF	Disabled
41	ON	open	YES	OFF	ON	no alarms in progress	OFF	Disabled
42	OFF	closed	YES	OFF	ON	no alarms in progress	OFF	Disabled
43	ON	closed	YES	OFF	ON	no alarms in progress	OFF	Disabled
44	OFF	open	NO	OFF	ON	no alarms in progress	OFF	Disabled
45	ON	open	NO	OFF	ON	no alarms in progress	OFF	Disabled
46	OFF	closed	NO	OFF	ON	no alarms in progress	OFF	Disabled
47	ON	closed	NO	OFF	ON	no alarms in progress	OFF	Disabled
48	OFF	open	YES	ON, depending on bF	OFF	no alarms in progress	OFF	Disabled
49	ON	open	YES	ON, depending on bF	OFF	no alarms in progress	OFF	Disabled
50	OFF	closed	YES	ON, depending on bF	OFF	no alarms in progress	OFF	Disabled
51	ON	closed	YES	ON, depending on bF	OFF	no alarms in progress	OFF	Disabled
52	OFF	open	NO	ON, depending on bF	OFF	no alarms in progress	OFF	Disabled
53	ON	open	NO	ON, depending on bF	OFF	no alarms in progress	OFF	Disabled
54	OFF	closed	NO	ON, depending on bF	OFF	no alarms in progress	OFF	Disabled
55	ON	closed	NO	ON, depending on bF	OFF	no alarms in progress	OFF	Disabled
56	OFF	open	YES	OFF	OFF	no alarms in progress	OFF	Disabled
57	ON	open	YES	OFF	OFF	no alarms in progress	OFF	Disabled
58	OFF	closed	YES	OFF	OFF	no alarms in progress	OFF	Disabled
59	ON	closed	YES	OFF	OFF	no alarms in progress	OFF	Disabled
60	OFF	open	NO	OFF	OFF	no alarms in progress	OFF	Disabled
61	ON	open	NO	OFF	OFF	no alarms in progress	OFF	Disabled
62	OFF	closed	NO	OFF	OFF	no alarms in progress	OFF	Disabled
63	ON	closed	NO	OFF	OFF	no alarms in progress	OFF	Disabled
64	OFF	open	YES	ON, depending on bF	ON	alarms in progress	ON, depending on bE	Disabled
65	ON	open	YES	ON, depending on bF	ON	alarms in progress	ON, depending on bE	Disabled
66	OFF	closed	YES	ON, depending on bF	ON	alarms in progress	ON, depending on bE	Disabled
67	ON	closed	YES	ON, depending on bF	ON	alarms in progress	ON, depending on bE	Disabled
68	OFF	open	NO	ON, depending on bF	ON	alarms in progress	ON, depending on bE	Disabled
69	ON	open	NO	ON, depending on bF	ON	alarms in progress	ON, depending on bE	Disabled
70	OFF	closed	NO	ON, depending on bF	ON	alarms in progress	ON, depending on bE	Disabled
71	ON	closed	NO	ON, depending on bF	ON	alarms in progress	ON, depending on bE	Disabled
72	OFF	open	YES	OFF	ON	alarms in progress	ON, depending on bE	Disabled
73	ON	open	YES	OFF	ON	alarms in progress	ON, depending on bE	Disabled
74	OFF	closed	YES	OFF	ON	alarms in progress	ON, depending on bE	Disabled
75	ON	closed	YES	OFF	ON	alarms in progress	ON, depending on bE	Disabled
76	OFF	open	NO	OFF	ON	alarms in progress	ON, depending on bE	Disabled
77	ON	open	NO	OFF	ON	alarms in progress	ON, depending on bE	Disabled
78	OFF	closed	NO	OFF	ON	alarms in progress	ON, depending on bE	Disabled
79	ON	closed	NO	OFF	ON	alarms in progress	ON, depending on bE	Disabled
80	OFF	open	YES	ON, depending on bF	OFF	alarms in progress	ON, depending on bE	Disabled
81	ON	open	YES	ON, depending on bF	OFF	alarms in progress	ON, depending on bE	Disabled
82	OFF	closed	YES	ON, depending on bF	OFF	alarms in progress	ON, depending on bE	Disabled
83	ON	closed	YES	ON, depending on bF	OFF	alarms in progress	ON, depending on bE	Disabled
84	OFF	open	NO	ON, depending on bF	OFF	alarms in progress	ON, depending on bE	Disabled
85	ON	open	NO	ON, depending on bF	OFF	alarms in progress	ON, depending on bE	Disabled
86	OFF	closed	NO	ON, depending on bF	OFF	alarms in progress	ON, depending on bE	Disabled
87	ON	closed	NO	ON, depending on bF	OFF	alarms in progress	ON, depending on bE	Disabled
88	OFF	open	YES	OFF	OFF	alarms in progress	ON, depending on bE	Disabled
89	ON	open	YES	OFF	OFF	alarms in progress	ON, depending on bE	Disabled
90	OFF	closed	YES	OFF	OFF	alarms in progress	ON, depending on bE	Disabled
91	ON	closed	YES	OFF	OFF	alarms in progress	ON, depending on bE	Disabled

b1	Alarm relay oscillation when "CY" alarm is on	Dilution drain with contactor	Drain if new request $\leq 2/3$ current request (contact open)	Total drain due to inactivity	Display of "CL" & "CP" alarms	Alarm relay activated if...	Periodical total drain	Enable management of steam request signal /external fan control relay M14
92	OFF	open	NO	OFF	OFF	alarms in progress	ON, depending on bE	Disabled
93	ON	open	NO	OFF	OFF	alarms in progress	ON, depending on bE	Disabled
94	OFF	closed	NO	OFF	OFF	alarms in progress	ON, depending on bE	Disabled
95	ON	closed	NO	OFF	OFF	alarms in progress	ON, depending on bE	Disabled
96	OFF	open	YES	ON, depending on bF	ON	no alarms in progress	ON, depending on bE	Disabled
97	ON	open	YES	ON, depending on bF	ON	no alarms in progress	ON, depending on bE	Disabled
98	OFF	closed	YES	ON, depending on bF	ON	no alarms in progress	ON, depending on bE	Disabled
99	ON	closed	YES	ON, depending on bF	ON	no alarms in progress	ON, depending on bE	Disabled
100	OFF	open	NO	ON, depending on bF	ON	no alarms in progress	ON, depending on bE	Disabled
101	ON	open	NO	ON, depending on bF	ON	no alarms in progress	ON, depending on bE	Disabled
102	OFF	closed	NO	ON, depending on bF	ON	no alarms in progress	ON, depending on bE	Disabled
103	ON	closed	NO	ON, depending on bF	ON	no alarms in progress	ON, depending on bE	Disabled
104	OFF	open	YES	OFF	ON	no alarms in progress	ON, depending on bE	Disabled
105	ON	open	YES	OFF	ON	no alarms in progress	ON, depending on bE	Disabled
106	OFF	closed	YES	OFF	ON	no alarms in progress	ON, depending on bE	Disabled
107	ON	closed	YES	OFF	ON	no alarms in progress	ON, depending on bE	Disabled
108	OFF	open	NO	OFF	ON	no alarms in progress	ON, depending on bE	Disabled
109	ON	open	NO	OFF	ON	no alarms in progress	ON, depending on bE	Disabled
110	OFF	closed	NO	OFF	ON	no alarms in progress	ON, depending on bE	Disabled
111	ON	closed	NO	OFF	ON	no alarms in progress	ON, depending on bE	Disabled
112	OFF	open	YES	ON, depending on bF	OFF	no alarms in progress	ON, depending on bE	Disabled
113	ON	open	YES	ON, depending on bF	OFF	no alarms in progress	ON, depending on bE	Disabled
114	OFF	closed	YES	ON, depending on bF	OFF	no alarms in progress	ON, depending on bE	Disabled
115	ON	closed	YES	ON, depending on bF	OFF	no alarms in progress	ON, depending on bE	Disabled
116	OFF	open	NO	ON, depending on bF	OFF	no alarms in progress	ON, depending on bE	Disabled
117	ON	open	NO	ON, depending on bF	OFF	no alarms in progress	ON, depending on bE	Disabled
118	OFF	closed	NO	ON, depending on bF	OFF	no alarms in progress	ON, depending on bE	Disabled
119	ON	closed	NO	ON, depending on bF	OFF	no alarms in progress	ON, depending on bE	Disabled
120	OFF	open	YES	OFF	OFF	no alarms in progress	ON, depending on bE	Disabled
121	ON	open	YES	OFF	OFF	no alarms in progress	ON, depending on bE	Disabled
122	OFF	closed	YES	OFF	OFF	no alarms in progress	ON, depending on bE	Disabled
123	ON	closed	YES	OFF	OFF	no alarms in progress	ON, depending on bE	Disabled
124	OFF	open	NO	OFF	OFF	no alarms in progress	ON, depending on bE	Disabled
125	ON	open	NO	OFF	OFF	no alarms in progress	ON, depending on bE	Disabled
126	OFF	closed	NO	OFF	OFF	no alarms in progress	ON, depending on bE	Disabled
127	ON	closed	NO	OFF	OFF	no alarms in progress	ON, depending on bE	Disabled
128	OFF	open	YES	ON (bF)	ON	alarms in progress	OFF	Enabled
129	ON	open	YES	ON (bF)	ON	alarms in progress	OFF	Enabled
130	OFF	closed	YES	ON (bF)	ON	alarms in progress	OFF	Enabled
131	ON	closed	YES	ON (bF)	ON	alarms in progress	OFF	Enabled
132	OFF	open	NO	ON (bF)	ON	alarms in progress	OFF	Enabled
133	ON	open	NO	ON (bF)	ON	alarms in progress	OFF	Enabled
134	OFF	closed	NO	ON (bF)	ON	alarms in progress	OFF	Enabled
135	ON	closed	NO	ON (bF)	ON	alarms in progress	OFF	Enabled
136	OFF	open	YES	OFF	ON	alarms in progress	OFF	Enabled
137	ON	open	YES	OFF	ON	alarms in progress	OFF	Enabled
138	OFF	closed	YES	OFF	ON	alarms in progress	OFF	Enabled
139	ON	closed	YES	OFF	ON	alarms in progress	OFF	Enabled
140	OFF	open	NO	OFF	ON	alarms in progress	OFF	Enabled
141	ON	open	NO	OFF	ON	alarms in progress	OFF	Enabled
142	OFF	closed	NO	OFF	ON	alarms in progress	OFF	Enabled
143	ON	closed	NO	OFF	ON	alarms in progress	OFF	Enabled
144	OFF	open	YES	ON (bF)	OFF	alarms in progress	OFF	Enabled
145	ON	open	YES	ON (bF)	OFF	alarms in progress	OFF	Enabled
146	OFF	closed	YES	ON (bF)	OFF	alarms in progress	OFF	Enabled
147	ON	closed	YES	ON (bF)	OFF	alarms in progress	OFF	Enabled
148	OFF	open	NO	ON (bF)	OFF	alarms in progress	OFF	Enabled
149	ON	open	NO	ON (bF)	OFF	alarms in progress	OFF	Enabled
150	OFF	closed	NO	ON (bF)	OFF	alarms in progress	OFF	Enabled
151	ON	closed	NO	ON (bF)	OFF	alarms in progress	OFF	Enabled
152	OFF	open	YES	OFF	OFF	alarms in progress	OFF	Enabled
153	ON	open	YES	OFF	OFF	alarms in progress	OFF	Enabled
154	OFF	closed	YES	OFF	OFF	alarms in progress	OFF	Enabled
155	ON	closed	YES	OFF	OFF	alarms in progress	OFF	Enabled
156	OFF	open	NO	OFF	OFF	alarms in progress	OFF	Enabled
157	ON	open	NO	OFF	OFF	alarms in progress	OFF	Enabled
158	OFF	closed	NO	OFF	OFF	alarms in progress	OFF	Enabled
159	ON	closed	NO	OFF	OFF	alarms in progress	OFF	Enabled
160	OFF	open	YES	ON (bF)	ON	no alarms in progress	OFF	Enabled
161	ON	open	YES	ON (bF)	ON	no alarms in progress	OFF	Enabled
162	OFF	closed	YES	ON (bF)	ON	no alarms in progress	OFF	Enabled
163	ON	closed	YES	ON (bF)	ON	no alarms in progress	OFF	Enabled
164	OFF	open	NO	ON (bF)	ON	no alarms in progress	OFF	Enabled
165	ON	open	NO	ON (bF)	ON	no alarms in progress	OFF	Enabled
166	OFF	closed	NO	ON (bF)	ON	no alarms in progress	OFF	Enabled
167	ON	closed	NO	ON (bF)	ON	no alarms in progress	OFF	Enabled
168	OFF	open	YES	OFF	ON	no alarms in progress	OFF	Enabled
169	ON	open	YES	OFF	ON	no alarms in progress	OFF	Enabled
170	OFF	closed	YES	OFF	ON	no alarms in progress	OFF	Enabled
171	ON	closed	YES	OFF	ON	no alarms in progress	OFF	Enabled
172	OFF	open	NO	OFF	ON	no alarms in progress	OFF	Enabled
173	ON	open	NO	OFF	ON	no alarms in progress	OFF	Enabled
174	OFF	closed	NO	OFF	ON	no alarms in progress	OFF	Enabled
175	ON	closed	NO	OFF	ON	no alarms in progress	OFF	Enabled
176	OFF	open	YES	ON (bF)	OFF	no alarms in progress	OFF	Enabled
177	ON	open	YES	ON (bF)	OFF	no alarms in progress	OFF	Enabled
178	OFF	closed	YES	ON (bF)	OFF	no alarms in progress	OFF	Enabled
179	ON	closed	YES	ON (bF)	OFF	no alarms in progress	OFF	Enabled
180	OFF	open	NO	ON (bF)	OFF	no alarms in progress	OFF	Enabled
181	ON	open	NO	ON (bF)	OFF	no alarms in progress	OFF	Enabled
182	OFF	closed	NO	ON (bF)	OFF	no alarms in progress	OFF	Enabled
183	ON	closed	NO	ON (bF)	OFF	no alarms in progress	OFF	Enabled
184	OFF	open	YES	OFF	OFF	no alarms in progress	OFF	Enabled
185	ON	open	YES	OFF	OFF	no alarms in progress	OFF	Enabled
186	OFF	closed	YES	OFF	OFF	no alarms in progress	OFF	Enabled

b1	Alarm relay oscillation when "CY" alarm is on	Dilution drain with contactor	Drain if new request \leq 2/3 current request (contact open)	Total drain due to inactivity	Display of "CL" & "CP" alarms	Alarm relay activated if...	Periodical total drain	Enable management of steam request signal /external fan control relay M14
187	ON	closed	YES	OFF	OFF	no alarms in progress	OFF	Enabled
188	OFF	open	NO	OFF	OFF	no alarms in progress	OFF	Enabled
189	ON	open	NO	OFF	OFF	no alarms in progress	OFF	Enabled
190	OFF	closed	NO	OFF	OFF	no alarms in progress	OFF	Enabled
191	ON	closed	NO	OFF	OFF	no alarms in progress	OFF	Enabled
192	OFF	open	YES	ON (bF)	ON	alarms in progress	ON (bE)	Enabled
193	ON	open	YES	ON (bF)	ON	alarms in progress	ON (bE)	Enabled
194	OFF	closed	YES	ON (bF)	ON	alarms in progress	ON (bE)	Enabled
195	ON	closed	YES	ON (bF)	ON	alarms in progress	ON (bE)	Enabled
196	OFF	open	NO	ON (bF)	ON	alarms in progress	ON (bE)	Enabled
197	ON	open	NO	ON (bF)	ON	alarms in progress	ON (bE)	Enabled
198	OFF	closed	NO	ON (bF)	ON	alarms in progress	ON (bE)	Enabled
199	ON	closed	NO	ON (bF)	ON	alarms in progress	ON (bE)	Enabled
200	OFF	open	YES	OFF	ON	alarms in progress	ON (bE)	Enabled
201	ON	open	YES	OFF	ON	alarms in progress	ON (bE)	Enabled
202	OFF	closed	YES	OFF	ON	alarms in progress	ON (bE)	Enabled
203	ON	closed	YES	OFF	ON	alarms in progress	ON (bE)	Enabled
204	OFF	open	NO	OFF	ON	alarms in progress	ON (bE)	Enabled
205	ON	open	NO	OFF	ON	alarms in progress	ON (bE)	Enabled
206	OFF	closed	NO	OFF	ON	alarms in progress	ON (bE)	Enabled
207	ON	closed	NO	OFF	ON	alarms in progress	ON (bE)	Enabled
208	OFF	open	YES	ON (bF)	OFF	alarms in progress	ON (bE)	Enabled
209	ON	open	YES	ON (bF)	OFF	alarms in progress	ON (bE)	Enabled
210	OFF	closed	YES	ON (bF)	OFF	alarms in progress	ON (bE)	Enabled
211	ON	closed	YES	ON (bF)	OFF	alarms in progress	ON (bE)	Enabled
212	OFF	open	NO	ON (bF)	OFF	alarms in progress	ON (bE)	Enabled
213	ON	open	NO	ON (bF)	OFF	alarms in progress	ON (bE)	Enabled
214	OFF	closed	NO	ON (bF)	OFF	alarms in progress	ON (bE)	Enabled
215	ON	closed	NO	ON (bF)	OFF	alarms in progress	ON (bE)	Enabled
216	OFF	open	YES	OFF	OFF	alarms in progress	ON (bE)	Enabled
217	ON	open	YES	OFF	OFF	alarms in progress	ON (bE)	Enabled
218	OFF	closed	YES	OFF	OFF	alarms in progress	ON (bE)	Enabled
219	ON	closed	YES	OFF	OFF	alarms in progress	ON (bE)	Enabled
220	OFF	open	NO	OFF	OFF	alarms in progress	ON (bE)	Enabled
221	ON	open	NO	OFF	OFF	alarms in progress	ON (bE)	Enabled
222	OFF	closed	NO	OFF	OFF	alarms in progress	ON (bE)	Enabled
223	ON	closed	NO	OFF	OFF	alarms in progress	ON (bE)	Enabled
224	OFF	open	YES	ON (bF)	ON	no alarms in progress	ON (bE)	Enabled
225	ON	open	YES	ON (bF)	ON	no alarms in progress	ON (bE)	Enabled
226	OFF	closed	YES	ON (bF)	ON	no alarms in progress	ON (bE)	Enabled
227	ON	closed	YES	ON (bF)	ON	no alarms in progress	ON (bE)	Enabled
228	OFF	open	NO	ON (bF)	ON	no alarms in progress	ON (bE)	Enabled
229	ON	open	NO	ON (bF)	ON	no alarms in progress	ON (bE)	Enabled
230	OFF	closed	NO	ON (bF)	ON	no alarms in progress	ON (bE)	Enabled
231	ON	closed	NO	ON (bF)	ON	no alarms in progress	ON (bE)	Enabled
232	OFF	open	YES	OFF	ON	no alarms in progress	ON (bE)	Enabled
233	ON	open	YES	OFF	ON	no alarms in progress	ON (bE)	Enabled
234	OFF	closed	YES	OFF	ON	no alarms in progress	ON (bE)	Enabled
235	ON	closed	YES	OFF	ON	no alarms in progress	ON (bE)	Enabled
236	OFF	open	NO	OFF	ON	no alarms in progress	ON (bE)	Enabled
237	ON	open	NO	OFF	ON	no alarms in progress	ON (bE)	Enabled
238	OFF	closed	NO	OFF	ON	no alarms in progress	ON (bE)	Enabled
239	ON	closed	NO	OFF	ON	no alarms in progress	ON (bE)	Enabled
240	OFF	open	YES	ON (bF)	OFF	no alarms in progress	ON (bE)	Enabled
241	ON	open	YES	ON (bF)	OFF	no alarms in progress	ON (bE)	Enabled
242	OFF	closed	YES	ON (bF)	OFF	no alarms in progress	ON (bE)	Enabled
243	ON	closed	YES	ON (bF)	OFF	no alarms in progress	ON (bE)	Enabled
244	OFF	open	NO	ON (bF)	OFF	no alarms in progress	ON (bE)	Enabled
245	ON	open	NO	ON (bF)	OFF	no alarms in progress	ON (bE)	Enabled
246	OFF	closed	NO	ON (bF)	OFF	no alarms in progress	ON (bE)	Enabled
247	ON	closed	NO	ON (bF)	OFF	no alarms in progress	ON (bE)	Enabled
248	OFF	open	YES	OFF	OFF	no alarms in progress	ON (bE)	Enabled
249	ON	open	YES	OFF	OFF	no alarms in progress	ON (bE)	Enabled
250	OFF	closed	YES	OFF	OFF	no alarms in progress	ON (bE)	Enabled
251	ON	closed	YES	OFF	OFF	no alarms in progress	ON (bE)	Enabled
252	OFF	open	NO	OFF	OFF	no alarms in progress	ON (bE)	Enabled
253	ON	open	NO	OFF	OFF	no alarms in progress	ON (bE)	Enabled
254	OFF	closed	NO	OFF	OFF	no alarms in progress	ON (bE)	Enabled
255	ON	closed	NO	OFF	OFF	no alarms in progress	ON (bE)	Enabled

Tab. 11.f

11.7 Controlling the board via network

The variables shown in the list are only some of the total variables available.
DO NOT CONFIGURE VARIABLES THAT ARE NOT SHOWN IN THE TABLE,
OTHERWISE THE OPERATION OF THE HUMIDIFIER MAY BE AFFECTED.

NOTE: The software release is made up of 4 digits and is shown on the sticker on the back of the controller. For example, the code "1.080" indicates: hardware release "1.0" and software release "8.0". Make sure the correct network address has been set for parameter C3 (internal variable I13) before setting the address of the UEY controllers. Each humidifier is configured by default with address 1, two units cannot have the same address.

"A"	
CAREL - Modbus®	analogue variables* (Modbus®: REGISTERS)
3	param. d9: rated capacity in kg/h (see the table of parameters)
4	param. d7: maximum production in kg/h (see the table of parameters)
15	param. d3: instant steam flow-rate in kg/h; read-only. Format "#### = #### (100 = 100 kg/h)".
30	param. d6: current (A); read-only. Format "#### = #### (16 = 16a)".
33	param. C8: maximum time with no data (sent to controller) over RS485 to generate stop production + "SU" alarm (see parameters table)

* The data from the controller should be interpreted with a decimal point.
E.g.: var. 3=150 means 15.0 kg/h

"I"	
CAREL Modbus®	integer variables (Modbus®: REGISTERS)
1	256 param. P0: maximum production (see the table of parameters)
2	257 param. A0: operating mode (see the table of parameters)
3	258 param. A1: unit of measure (see the table of parameters)
4	259 param. A2: type of production request (see the table of parameters)
5	260 param. b1: additional functions (see the table of parameters)
6	261 param. b2: off delay time (see the table of parameters)
7	262 param. b4: water conductivity (see the table of parameters)
8	263 param. b5: conductivity pre-alarm threshold (see the table of parameters)
9	264 param. b6: conductivity alarm threshold (see the table of parameters)
10	265 param. b7: foam control threshold (see the table of parameters)
11	266 param. b8: conductivity control inside the cylinder in steady operation compared to rated value
12	267 param. C0: rated value displayed (see the table of parameters)
13	268 param. C3: serial port address (see the table of parameters)
14	269 param. C4: baud rate (see the table of parameters)
15	270 param. C5: supervisor: frame (see the table of parameters)
16	271 param. C6: serial response transmission delay (see the table of parameters)
17	272 param. b9: reduce duration of drain to dilute cycle (see the table of parameters)
18	273 param. bb: cylinder maintenance limit time in hours (see the table of parameters)
19	274 param. bE: time limit between two periodical drain cycles (see the table of parameters)
20	275 param. bF: days delay for drain due to inactivity (see the table of parameters)
44	299 param. d1: external control signal - see paragraph "controlling production using variables I62 and I63, read-only; example format" #### = #### (0%-100%, step 1%)
46	301 humidifier status (read-only) 0 = not active (no request, shutdown or disabled); 1 = start evaporation cycle; 2 = water fill in progress; 3 = evaporation in progress ; 4 = AFS drain ; 5 = water drain (to dilute or manual); 6 = end of water drain; 7 = complete drain for long inactivity; 8 = complete drain from manual or network control; 9 = no water management; 10 = pre-wash; 11 = periodical drain
47	302 type of humidification stage (read-only) 0 = not active; 1 = soft start; 2 = start of steady production the reduced production; 3 = steady production; 4 = reduced production; 5, 6, 7 = soft start
49	304 param. d5: conductivity of supply water [µS/cm] read-only, see the table of parameters
54	309 param. db: unit hour counter (not resettable, see the table of parameters)
55	310 param. dA: cylinder hour counter (resettable, see the table of parameters)
62	317 controls via RS485 ; bit 0: reset alarm log; bit 1: reset counter dA; bit 2: production request via variable I63; bit 3: pre-wash; bit 4: reset active alarms. ; Bit 6: fl ag to enable stop production + alarm for serial disconnected; Bit 7: fl ag to request oldest alarm; Bit 8: fl ag to request most recent alarm; Bit 9: fl ag to load first alarm in log; Bit 12: fl ag to enable create user backup. Except for bit2, the others are always read as 0. On power-up, all the bits are equal to 0.
63	318 production request via network (when I62 bit2 = 4) (0%-100%, step 1%).
64	319 match-digit of control board (read-only)
67	322 param. c7 (see the table of parameters)
70	325 param. A5 (see the table of parameters)
83	338 alarm status: Bit 0: at least one BLOCK alarm present ; Bit 1: at least one DISAB alarm present; Bit 2: at least one WARN alarm present
84	339 alarms with shutdown (read-only) bit n=0 alarm not active, bit n=1 alarm active. See table of alarms: bit 0: alarm Mn; bit 1: alarm EC; bit 2: alarm E1; bit 3: alarm E0; bit 4: alarm EH; bit 5: alarm EP; bit 6: not used; bit 7: not used.
85	340 alarms with disabling (read-only) bit n=0 alarm not active, bit n=1 alarm active. See table of alarms: bit 0: alarm EU (automatic reset); bit 1: alarm E3; bit 2: alarm EF (automatic reset); bit 3: alarm Ed; bit 4: not used; bit 5: not used; bit 6: not used; bit 7: not used.
86	341 warnings (read-only) bit n=0 alarm not active, bit n=1 alarm active. See table of alarms: bit 0: pre-alarm CY; bit 1: warning Ec; bit 2: pre-alarm EA; bit 3: pre-alarm CP; bit 4: pre-alarm CL; bit 5, bit 6, bit 7: not used
89	344 read line in alarm log (see variable I62, bit7-8-9)

CAREL

"D"	digital variables (Modbus®: COILS)
CAREL - Modbus®	
1	humidifier disabled by remote ON/OFF (terminals M2.4 M2.5) read-only
2	disabling control signal: D2=1 => CPY disabled; D2=0 => CPY enabled (similar to remote ON/OFF)
3	humidifier ready and awaiting request (read-only)
4	contactor status: 0 = open, 1 = closed (read-only)
5	status of 24 Vac drain output: 0 = no drain, 1 = drain (read-only)
6	status of drain relay output: 0 = no drain, 1 = drain (read-only)
7	cumulative alarm relay: 0 = not energised, 1 = energised (read-only)
8	status of 24 Vac fill output: 0 = no fill, 1 = fill (read-only)
10	high water level: 0 = probes not activated, 1 = probes activated (read-only)
17	manual drain control: 0 = not active, 1 = active; if set to 1 via the network, the drain will be performed until max. time or variable 'D17' is reset
19	UEY terminal connected and on-line: 0 = not on-line, 1 = on-line (read-only)

11.8 Controlling production using variables I62 and I63

1. Via network, immediately after start-up, set D2 = 0 (D2 does not need to be set again if the board is not switch off).
2. Set I2 = 0 for ON/OFF control (A0 = 0), I2 = 1 for proportional control (A0 = 1)
3. Set I62 = 4 to send the request via variable I63. If A0=0, if I63 ≤50: OFF; if I63 ≥51: ON
4. Write the production request to variable I63, format 000 to 100 (0% to 100%).

NOTE: if bit6=1 in variable I62, steam production will stop when there is no control data flow over the RS485 serial link for a period exceeding the time set for parameter C8.

Production can resume when new data is sent.

11.9 Read alarm log via the network

Supervisor variable I89 shows the alarms saved in the log, one at a time. Normally this variable will always show the code of the most recent alarm; to scroll all the alarms saved, set the following bits of variable I62:

Variable I62 - bit7: Flag to request previous alarm (write-only)

Loads the code of the alarm saved prior to the current alarm displayed into variable I89.

If the current alarm is the oldest, the value 0 is loaded.

Variable I62 - bit8: Flag to request next alarm (write-only)

Loads the code of the alarm saved immediately after the current alarm displayed into variable I89.

If the current alarm is the most recent (for example after having set bit 0x0200), the value 0 is loaded

Variable I62 - bit9: Flag to load the last alarm in the log (write-only)

Loads the code of the most recent alarm into variable I89

The log can hold the most recent 366 alarms.

11.10 Loss of network communication

If there is a loss in network communication, UEY stops the unit by opening the contactor; UEY then goes into standby, without producing steam, and alarm E3 is displayed. Steam production resumes as follows:

- Communication is restored with the external controller: UEY automatically responds to the request from the external controller, and alarm E3 disappears.
- UEY is switched off and on again: UEY responds to the request from the external controller (if communication has been restored) or from the external signal (0-10 V, 4-20 mA, etc.) sent to terminals M2:1-2-3. In this way, if communication with the external controller is interrupted, steam production can be started again by switching UEY off and on again and sending the request using an external signal, 0-10 V (4-20 mA, etc.).

11.11 Modbus® protocol on the UEY boards

The Modbus® protocol can be selected using parameter C7 (see “Serial connection parameters”).

Chapter 7 shows a list of variables and the corresponding addresses. For multiple read/writes, the maximum number of “Register” or “Coil” variables is 20.

The following functions are available::

- MB_READ_COIL_STATUS 1: used to request the status (ON or OFF) of a certain number of “Coil” variables (binary, 1 bit), starting from the specified address. Broadcast mode is not allowed.
- MB_READ_INPUT_STATUS 2: operationally identical to the above.
- MB_READ_HOLDING_REG 3: used to request the value of a consecutive block of “Register” variables (numeric, 16 bit). Broadcast mode is not allowed.
- MB_READ_INPUT_REG 4: operationally identical to the above.
- MB_FORCE_SINGLE_COIL 5: used to set the status of an individual “Coil” variable (binary, 1 bit) to ON or OFF (specifying the address of the bit in question). Broadcast mode is allowed.
- MB_PRESET_SINGLE_REG 6: used to set the value of an individual “Register” variable (numeric, 16 bit). Broadcast mode is allowed.
- MB_FORCE_MULTIPLE_COIL 15: used to set the status of a consecutive block of “Coil” variables (binary, 1 bit) (specifying the number of bits and number of bytes). Broadcast mode is allowed
- MB_PRESET_MULTIPLE_REG 16: used to set the value of a consecutive block of “Register” variables (numeric, 16 bit). Broadcast mode is allowed.

11.12 Exceptions managed

01 illegal function

02 illegal data address

03 illegal data value

12. ADVANCED FUNCTIONS

12.1 Operating principle

Immersed electrode humidifiers manufacture steam by boiling the water contained inside the cylinder. The heat required to boil the water is produced by passing an electrical current through the cylinder. This is done by applying a voltage to the electrodes immersed in the water. Initially, when the cylinder is new or has just been cleaned, the current depends almost exclusively on the type of supply water: the more salts in the water, the higher the current, and the required steam production is achieved quicker. Over time the salt deposits in the cylinder increase (these do not evaporate with the water), helping achieve the rated production. In steady operation, the level of production required is maintained automatically by controlling the current input, adjusting the level of water in the cylinder.

The salts that deposit over time cause the progressive depletion of the cylinder. To avoid excessive accumulation, the humidifier automatically drains and replenishes a certain quantity of water at set intervals.

12.2 Control principles

ON/OFF control

The action is all or nothing, activated by an external contact that consequently determines the control set point and differential.

The external contact may be a humidistat, whose status determines the operation of the humidifier:

- contact closed: the humidifier produces steam if the remote ON/OFF contact is also closed;
- contact open: the production of steam ends.

Proportional control

The production of steam is proportional to the value of a signal "Y" from an external device. The type of signal can be selected between the following standards: 0 to 10 Vdc, 2 to 10 Vdc, 0 to 20 mA, 4 to 20 mA.

The entire range is indicated as the proportional band. The maximum production of the humidifier, corresponding to the value maximum of the external signal, can be set from 20% to 100% of the rated value of the humidifier (parameter P0).

The minimum production has an activation hysteresis, hy, equal to 5% of the proportional band of the external signal "Y".

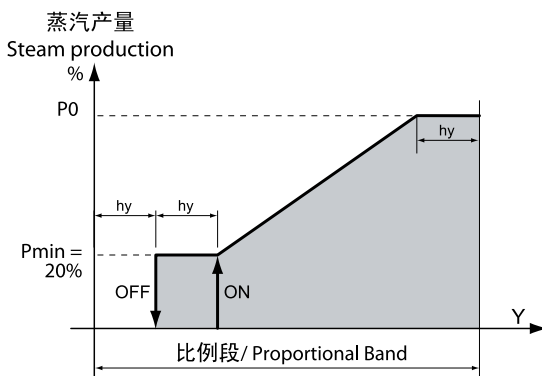

Fig. 12.a

Control with humidity probe (see fig. 12.b)

The production of steam is related to the reading of the probe and increases as the relative humidity value read decreases. The production reaches the maximum when the relative humidity is lower than the set point (St) by a value at least equal to the proportional band (P1). The maximum production may be programmed between 20% and 100% of the rated value of the humidifier (and between the 10% and 100% in series operation). To set the set point and differential for the main control probe: "SET" screen > set point and proportional band. The minimum production has an activation hysteresis, hy, equal to 2% of the range.

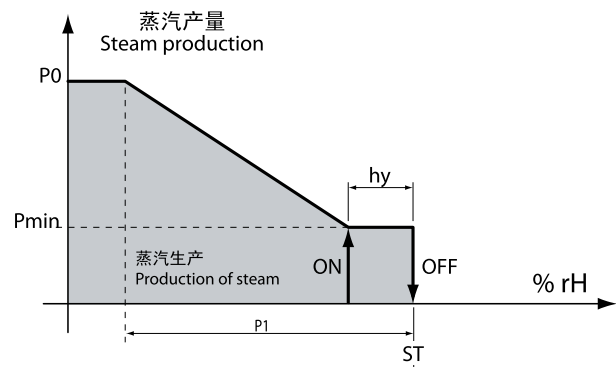

Fig. 12.b

Application for steam baths: autonomous control with temperature transducer (NTC), parameter A0=2 and A2=5

In applications for steam baths, where the control probe measures temperature rather than humidity, the same considerations are valid as described in paragraph Control with humidity probe, replacing relative humidity with temperature.

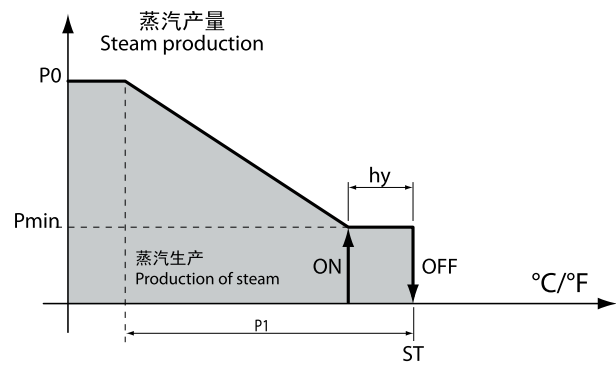

Fig. 12.c

12.3 Supply water conductivity

Conductivity measurement and alarms

The conductivity of the supply water is measured by the conductivity meter when the fill solenoid valve is opened.

Two programmable alarm thresholds are available:

- b5: warning threshold (signal only without activating the alarm relay, automatic reset when the condition is no longer present);
- b6: alarm threshold (unit shutdown with activation of the alarm relay).

The alarm is activated when the reading exceeds one of the two thresholds continuously for 60 minutes, or alternatively instantly if the value read is 3 times higher than the threshold.

To disable the alarm signal, simply set the thresholds above the maximum value of the reading.

12.4 Automatic draining

The humidifier automatically drains and replaces some of the water contained in the cylinder, to prevent an excessive concentration of salts following the evaporation process.

The drain pump is opened for a set time whenever the conductivity exceeds the maximum limit; this situation is measured indirectly by evaluating the evaporation speed.

During the automatic draining phase, the electrodes are off, so as to prevent the drain water from carrying current (the display shows "dr").

Drain due to excess foam

With certain types of supply water, foam may form during the production of steam just above the water. This situation must be resolved, as it may cause water to be released together with the steam. For this purpose, two electrodes are fitted on the top of the cylinder. When these electrodes detect the presence of foam, the humidifier activates a series of repeated drain cycles. If the situation persists, the complete washing of the cylinder is activated.

Drain due to inactivity

In humidifier does not operate for an extended time (it remains on but does not produce steam), the water in the cylinder is drained automatically, to avoid stagnation and hygiene risks. The inactivity time is set using parameter "bF" (default 3 days). The function can be disabled by setting parameter b1 (see paragraph 11.6).

Powered draining

When running an automatic drain cycle due to excessive salt, the electrodes are not powered and the production of steam is thus reduced. To keep the electrodes powered during the drain cycle set parameter b1 (see paragraph 11.6).

Draining due to a significant reduction in the request for production

In the event of a significant reduction in the request for steam production, the humidifier, rather than wait for the level of water (and thus the production) to decrease due to the effect of the production itself, performs a drain cycle. The reduction in the request for steam production is considered significant if the current is 33% higher than that relating to the requested level. This function can be disabled. Set parameter b1 (see paragraph 11.6)

Periodical drain

When using water rich in substances such as humus and lime, a periodical drain cycle should be set for the cylinder to avoid accumulating residues. To enable the periodical drain, set parameter b1 to 64. In this way, every 24 h the humidifier will drain all the stagnant water in the cylinder, and the display will show code "dP" (periodical drain). If the periodical drain is enabled, the number of hours between two periodical drain cycles can be set using parameter "bE".

 **Note:** For the manual drain function, see chap. 6, for the mechanical drain see paragraph 9.4.

12.5 Automatic insufficient supply water management

The humidifier checks whether there is no supply water or the flow-rate of supply water is too low, by controlling if the current at the electrodes increases after opening the fill solenoid valve.

In this case, the humidifier:

- displays alarm "EF"
- activates the alarm relay,
- opens the contactor and closes the fill solenoid valve for 10 minutes.

After the 10 minutes, the fill solenoid valve is opened, the contactor closed and the phase current measured: if it increases the alarm is deactivated, otherwise the procedure is repeated.

 **Nota:** the alarm is reset automatically and is managed according to the procedure described above.

12.6 Alarm relay switching

Once the operating hours corresponding to the cylinder maintenance request have been reached ("CY" alarms), the alarm relay (if there are no other alarms active) will switch for 10 seconds every 12 hours, until reaching the "Mn" alarm. This function is activated using parameter b1 (see paragraph 11.6); normally disabled.

12.7 Auxiliary contact management (active fan request)

The auxiliary contact can be used to:

- remote signalling of steam production request (but not the actual value);
- activation/deactivation of an external fan unit, based on whether the steam production request is present.

Activating this function by parameter b1, the contact is activated (CLOSED) during steam production, with a delay of A6 seconds, and deactivated (OPEN) with a delay of A7 seconds.

During A6 and A7 the symbol (fan) will flash on the display, during activation the symbol (fan) will be on steady.

During the manual drain (see Chap. 6.12) the contact will be deactivated (always after the delay A7).

During pre-wash (see Chap. 6.1) the contact be activated, with the corresponding delays.

12.8 Manual procedure

This procedure is used to manually control the devices on the humidifier. From the main screen, press the PRG button for 2 seconds.

Enter the password 70 using UP or DOWN.

The display will show **MAn**

Press PRG.

The display will show **tlr**

Then scroll the various devices using UP and DOWN:

- **tlr** = Contactor
- **drn** = Drain pump
- **FIL** = Fill SV
- **drt** = Drain tempering SV (not used)
- **ALr** = Alarm relay
- **FAn** = Auxiliary contact (fan)

Pressing PRG from any these options shows:

- ON if the device is currently active
- OFF if the device is currently inactive

Press PRG; the display starts flashing

Press UP or DOWN to modify the value

Press PRG to confirm.

Press ESC to return to the previous display.

N.B. THE MODE CAN ONLY BE EXITED USING THE ESC BUTTON FROM THE MAn DISPLAY OR BY SWITCHING OFF THE HUMIDIFIER.



12.9 LEDs on the control board

There are three LEDs fitted on the expansion board, located above the control board:



Fig. 12.d

Key:

LED on board	Symbol on display	Meaning
Red		alarm in progress (the type of alarm can be identified based on the type of flashing, see chap. 8)
Yellow		steam production in progress (led always on for 100% production, 2 blinkng 20%, 3 blinking 30%, ...)
Green		humidifier on

Tab. 12.a

NOTE: The yellow and red LEDs are active only if the display is disconnected.

CAREL

CAREL INDUSTRIES HQs

Via dell'Industria, 11 - 35020 Brugine - Padova (Italy)
Tel. (+39) 049.9716611 - Fax (+39) 049.9716600
e-mail: carel@carel.com - www.carel.com

代理 / Agency: