

Installation and maintenance manual
Manuel d'installation et de maintenance
Installations- und Wartungshandbuch
Manuale di installazione e di manutenzione
Manual de instalación y de mantenimiento

AQVL/AQVC/AQVH/AQVR



English

Français

Deutsch

Italiano

Español



80
↓
140 kW



90
↓
150 kW



Air-Cooled Water Chillers and Heat Pumps
Refroidisseurs d'Eau et Pompe à Chaleur Refroidis à l'Air
Luftgekühlte Flüssigkeitskühler und Wärmepumpen
Refrigeratori d'Acqua e Pompe di Calore Raffreddati ad Aria
Enfriadores de Agua y Bomba de Calor Condensadas con Aire

Part number / Code / Code / Codice / Código: **342598/A**
Supersedes / Annule et remplace / Annulliert und ersetzt / Annulla e sostituisce /
Anula y sustituye: **035B09040-300**
Notified Body / Organisme Notifié / Benannte Zertifizierungsstelle /
Organismo Notificato / Organismo Notificado N°. **1115 PASCAL**



ISO 9001:2008 certified management system

1 FOREWORD		7 GENERAL DESCRIPTION	
1.1 Introduction	2	7.1 General Information	28
1.2 Warranty	2	7.2 Body and Frame	28
1.3 Emergency stop/Normal stop	2	7.3 Compressors	28
1.4 An introduction to this manual	2	7.4 Evaporators	28
2 SAFETY		7.5 Condensing coils	28
2.1 Foreword	3	7.6 Condenser Fans	28
2.2 Definitions	3	7.7 Fans Control	28
2.3 Access to the unit	4	7.8 Refrigerating Circuits	28
2.4 General precautions	4	7.9 Control Supply Panel	28
2.5 Precautions against residual risks	4	8 TECHNICAL DATA	
2.6 Precautions during maintenance operations	5	8.1 Pressure drops	31
2.7 Safety labels	6	8.2 Technical data	32
2.8 Safety regulations	8	8.3 Unit electrical data	39
3 TRANSPORT, LIFTING AND POSITIONING		8.4 Hydraulic Features	41
3.1 Inspection	11	8.5 Position of shock adsorbers and weight distribution on supports	43
3.2 Lifting	11	8.6 Dimensional Drawings	49
3.3 Anchoring	12	8.7 Service spaces	51
3.4 Storage	12	9 MAINTENANCE	
4 INSTALLATION		9.1 General requirements	52
4.1 Positioning of the unit	13	9.2 Planned maintenance	52
4.2 Spring Isolator Installation	13	9.3 Refrigerant charge	53
4.3 External Water Circuit	14	9.4 Compressor	53
4.4 Water connections	17	9.5 Condenser	53
4.5 Defrost water drainage (only for AQVH units)	17	9.6 Fans	53
4.6 Power supply	17	9.7 Dehydrating filter	53
4.7 Electrical connections	18	9.8 Sight glass	53
4.8 Connecting plate-type evaporator temperature sensors	18	9.9 Electronic expansion valve	54
4.9 Microchannel type condenser coils	20	9.10 Evaporator	54
5 START-UP		10 TROUBLESHOOTING	55
5.1 Preliminary check	21	11 SPARE PARTS	
5.2 Start-up	21	11.1 Spare part list	57
5.3 Checking the operation	22	11.2 Oil for compressors	57
5.4 Delivery to the customer	22	11.3 Wiring diagrams	57
6 GENERAL INFORMATION		12 DISMANTLING, DEMOLITION AND SCRAPPING	
6.1 Control of AQVL/AQVH/AQVC with 4 compressors the "Chiller Control" system	23	12.1 Generalities	58
6.2 Display	24		
6.3 Keyboard	24		
6.4 Protection and Safety Equipment	27		

1 FOREWORD

1.1 Introduction

Units, manufactured to state-of-the-art design and implementation standards, ensure top performance, reliability and fitness to any type of air-conditioning systems.

These units are designed for cooling water or glycolated water (and for water heating in heat pump models) and are unfit for any purposes other than those specified in this manual.

This manual includes all the information required for a proper installation of the units, as well as the relevant operating and maintenance instructions.

It is therefore recommended to read this manual carefully before installation or any operation on the machine. The chiller installation and maintenance must be carried out by skilled personnel only (where possible, by one of Authorised Service Centers).

The manufacturer may not be held liable for any damage to people or property caused by improper installation, start-up and/or improper use of the unit and/or failure to implement the procedures and instructions included in this manual.

1.2 Warranty

These units are delivered complete, tested and ready for being operated. Any form of warranty will become null and void in the event that the appliance is modified without manufacturer's preliminary written authorisation.

This warranty shall apply providing that the installation instructions have been complied with (either issued by manufacturer, or deriving from the current practice), and the Form 1 ("Start-up") has been filled-in and mailed to manufacturer (attn. After-Sales Service).

In order for this warranty to be valid, the following conditions shall be met:

- The machine must be operated only by skilled personnel from Authorised After-Sales Service.
- Maintenance must be performed only by skilled personnel - from one of Authorised After-Sales Centers.
- Use only original spare parts.
- Carry out all the planned maintenance provided for by this manual in a timely and proper way.

Failure to comply with any of these conditions will automatically void the warranty.

1.3 Emergency stop / Normal stop

The emergency stop of the unit can be enabled using the master switch on the control panel (move down the lever).

For a normal stop, press the relevant push-buttons.

To restart the appliance, follow the procedure detailed in this manual.

1.4 An introduction to the manual

For safety reasons, it is imperative to follow the instructions given in this manual. In case of any damage caused by non-compliance with these instructions, the warranty will immediately become null and void.

Conventions used throughout the manual:



The Danger sign recalls your attention to a certain procedure or practice which, if not followed, may result in serious damage to people and property.



The Warning sign precedes those procedures that, if not followed, may result in serious damage to the appliance.



The Notes contain important observations.



The Useful Tips provide valuable information that optimises the efficiency of the appliance.

This manual and its contents, as well as the documentation which accompanies the unit, are and remain the property of manufacturer, which reserves any and all rights thereon. This manual may not be copied, in whole or in part, without manufacturer's written authorization.

2 SAFETY

2.1 Foreword

These units must be installed in conformity with the provisions of Machinery Directive 98/37/EC, Low Voltage Directive 2006/95/EC, Pressure Vessels Directive 97/23/EC, Electromagnetic Interference Directive 89/336/EC, as well as with other regulations applicable in the country of installation. If these provisions are not complied with, the unit must not be operated.



The unit must be grounded, and no installation and/or maintenance operations may be carried out before deenergising the electrical panel of the unit.

Failure to respect the safety measures mentioned above may result in electrocution hazard and fire in the presence of any short-circuits.



Inside the heat exchangers, the compressors and the refrigeration lines, this unit contains liquid and gaseous refrigerant under pressure. The release of this refrigerant may be dangerous and cause injuries.



The units are not designed to be operated with natural refrigerants, such as hydrocarbons. Manufacturer may not be held liable for any problems deriving from the replacement of original refrigerant or the introduction of hydrocarbons.

Units are designed and manufactured according to the requirements of European Standard PED 97/23/EC (pressure vessels).

- The used refrigerants are included in group II (non-hazardous fluids).
- The maximum working pressure values are mentioned on the unit's data plate.
- Suitable safety devices (pressure switches and safety valves) have been provided, to prevent any anomalous overpressure inside the plant.
- The vents of the safety valves are positioned and oriented in such a way as to reduce the risk of contact with the operator, in the event that the valve is operated. Anyway, the installer will convey the discharge of the valves far from the unit.
- Dedicated guards (removable panels with tools) and danger signs indicate the presence of hot pipes or components (high surface temperature).



The guards of the fans (only for units provided with air heat exchangers) must be always mounted and must never be removed before de-energising the appliance.



It is the User's responsibility to ensure that the unit is fit for the conditions of intended use and that both installation and maintenance are carried out by experienced personnel, capable of respecting all the recommendations provided by this manual. It is important that the unit is adequately supported, as detailed in this manual. Non-compliance with these recommendations may create hazardous situations for the personnel.



The unit must rest on a base which meets the characteristics specified in this manual; a base with inadequate characteristics is likely to become a source of serious injury to the personnel.



The unit has not been design to withstand loads and/or stress that may be transmitted by adjacent units, piping and/or structures. Each external load or stress transmitted to the unit may break or cause breakdowns in the unit's structure, as well as serious dangers to people. In these cases, any form of warranty will automatically become null and void.



The packaging material must not be disposed of in the surrounding environment or burnt.

2.2 Definitions

OWNER: means the legal representative of the company, body or individual who owns the plant where unit has been installed; he/she has the responsibility of making sure that all the safety regulations specified in this manual are complied with, along with the national laws in force.

INSTALLER: means the legal representative of the company who has been given by the owner the job of positioning and performing the hydraulic, electric and other connections of unit to the plant: he/she is responsible for handling and properly installing the appliance, as specified in this manual and according to the national regulations in force.

OPERATOR: means a person authorised by the owner to do on unit all the regulation and control operations expressly described in this manual, that must be strictly complied with, without exceeding the scope of the tasks entrusted to him.

ENGINEER: means a person authorised directly by manufacturer or, in all EC countries, excluding Italy, under his full responsibility, by the distributor of product, to perform any routine and extraordinary maintenance operations, as well as any regulation, control, servicing operations and the replacement of pieces, as may be necessary during the life of the unit.

2.3 Access to the unit

The unit must be placed in an area which can be accessed also by OPERATORS and ENGINEERS; otherwise the unit must be surrounded by a fence at not less than 2 meters from the external surface of the machine.

OPERATORS and ENGINEERS must enter the fenced area only after wearing suitable clothing (safety shoes, gloves, helmet etc.). The INSTALLER personnel or any other visitor must always be accompanied by an OPERATOR.

For no reason shall any unauthorised personnel be left alone in contact with the unit.

2.4 General precautions

The OPERATOR must simply use the controls of the unit; he must not open any panel, other than the one providing access to the control module.

The INSTALLER must simply work on the connections between plant and machine; he must not open any panels of the machine and he must not enable any control.

When you approach or work on the unit, follow the precautions listed below:

- do not wear loose clothing or jewellery or any other accessory that may be caught in moving parts
- wear suitable personal protective equipment (gloves, goggles etc.) when you have to work in the presence of free flames (welding operations) or with compressed air
- if the unit is placed in a closed room, wear ear protection devices
- cut off connecting pipes, drain them in order to balance the pressure to the atmospheric value before disconnecting them, disassemble connections, fil-

ters, joints or other line items

- do not use your hands to check for any pressure drops
- use tools in a good state of repair; be sure to have understood the instructions before using them
- be sure to have removed all tools, electrical cables and any other objects before closing and starting the unit again

2.5 Precautions against residual risks

Prevention of residual risks caused by the control system

- be sure to have perfectly understood the operating instructions before carrying out any operation on the control panel
- when you have to work on the control panel, keep always the operating instructions within reach
- start the unit only after you have checked its perfect connection to the plant
- promptly inform the ENGINEER about any alarm involving the unit
- do not reset manual restoration alarms unless you have identified and removed their cause

Prevention of residual mechanical risks

- install the unit according to the instructions provided in this manual
- carry out all the periodical maintenance operations prescribed by this manual
- wear a protective helmet before accessing the interior of the unit
- before opening any panelling of the machine, make sure that it is secured to it by hinges
- do not touch air condensation coils without wearing protective gloves
- do not remove the guards from moving elements while the unit is running
- check the correct position of the moving elements' guards before restarting the unit

Prevention of residual electrical risks

- connect the unit to the mains according to the instructions provided in this manual
- periodically carry out all the maintenance operations specified by this manual
- disconnect the unit from the mains by the external disconnecting switch before opening the electrical board

Safety

- check the proper grounding of the unit before start-up
- check all the electrical connections, the connecting cables, and in particular the insulation; replace worn or damaged cables
- periodically check the board's internal wiring
- do not use cables having an inadequate section or flying connections, even for limited periods of time or in an emergency
- make sure that on-off remote controls are inhibited
- wear suitable personal protective equipment (helmet, safety gloves, goggles and shoes etc.)

To carry out any measurements or checks which require the activation of the machine:

- work with the electrical board open only for the necessary time
- close the electrical board as soon as the measurement or check has been completed
- for outdoor units, do not carry out any operations in the presence of dangerous climatic conditions (rain, snow, mist etc.)

Prevention of other residual risks

- make sure that the connections to the unit conform to the instructions provided in this manual and on the unit's panelling
- if you have to disassemble a piece, make sure that it has been properly mounted again before restarting the unit
- do not touch the delivery pipes from the compressor, the compressor and any other piping or component inside the machine before wearing protective gloves
- keep a fire extinguisher for electrical appliances near the machine
- on the units installed indoor, connect the safety valve of the refrigeration circuit to a piping network that can channel any overflowing refrigerant outside
- remove and leak of fluid inside and outside the unit
- collect the waste liquids and dry any oil spillage
- periodically clean the compressor compartment, to remove any fouling
- do not store flammable liquids near the unit
- do not disperse the refrigerant and the lubricating oil into the environment
- weld only empty pipes; do not approach flames or other sources of heat to refrigerant pipes
- do not bend/hit pipes containing fluids under pressure

The following precautions must be always adopted:

- do not scatter the fluids of the refrigeration circuit in the surrounding environment
- when replacing an eprom or electronic cards, use always suitable devices (extractor, antistatic bracelet, etc.)
- to replace a compressor, the evaporator, the condensing coils or any other weighty element, make sure that the lifting equipment is consistent with the weight to be lifted
- in air units with independent compressor compartment, do not access the fan compartment unless you have disconnected the machine by the disconnecting switch on the board and you have placed a warning sign "do not turn on - maintenance in progress"
- contact manufacturer for any modifications to the refrigeration, hydraulic or wiring diagram of the unit, as well as to its control logics
- contact manufacturer if it is necessary to perform very difficult disassembly and assembly operations
- use only original spare parts purchased directly from manufacturer or the official retailers of the companies on the recommended spare parts list
- contact manufacturer if it is necessary to handle the unit one year after its positioning on site or if you wish to dismantle it.

2.6 Precautions during maintenance operations

Maintenance operations can be carried out by authorised technicians only.

Before performing any maintenance operations:

- disconnect the unit from the mains with the external disconnecting switch
- place a warning sign "do not turn on - maintenance in progress" on the external disconnecting switch

2.7 Safety labels

The labels below will be affixed to each unit in the indicated point:



Identification of the refrigerant External door

COD. PRODOTTO PRODUCT CODE	(A)
MODELLO MODEL	(B)
CE (C)	Book icon (C)
MATRICOLA SERIAL NUMBER	(D)
ANNO DI COSTRUZIONE YEAR OF CONSTRUCTION	(E)
CARICA REFR. X CIRCUIT (1/2/3/4) REFRIGERANT CHARGE	kg (F) (G) (G) (G) (G)
ALTA PRESSIONE HIGH PRESSURE	in/psi bar (H)
BASSA PRESSIONE LOW PRESSURE	in/psi bar (I)
ALTA POTENZA MAX SUPPLY	W/Hz (L)
CORRENTE DI SPUNTO ISA	in/psi A (M)
CORRENTE A PIENO CARICO PLA	in/psi A (N)
POTENZA ASSORBITA POWER INPUT	in/psi kW (O)
PRESS. ESERC. ACQUA WATER OPERATING PRESSURE	bar (P)
MASSA MASS	kg (Q) CREAÇÃO IP IP CLASS (R)
RECO INDUSTRIES S.L. Via XXV Aprile 27 30026 BARLESINA (VE) ITALIA MADE IN ITALY C.O.00000402-000 E	
MODELLO: MATRICOLA: CODICE:	ANNO DI COSTRUZIONE
MODELLO: MATRICOLA: CODICE:	ANNO DI COSTRUZIONE
MODELLO: MATRICOLA: CODICE:	ANNO DI COSTRUZIONE

Identification of the unit Outside, on the right-hand front column

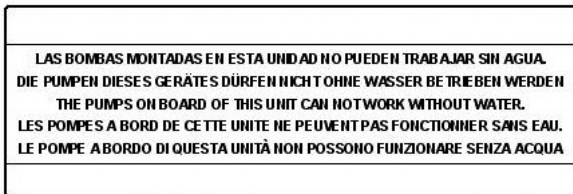

Pump operation - Outside, on the right-hand front column

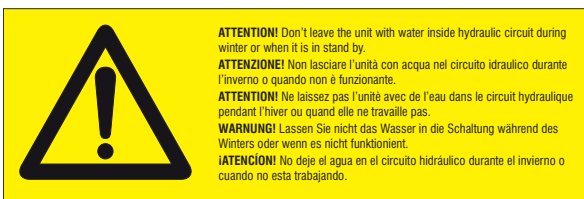

Circuit drain - Outside, on the right-hand front column

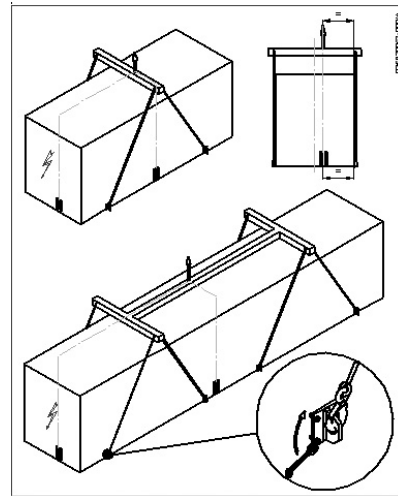

Instruction for the lifting



Sequence phase control on the electrical board



Gravity centre - Base

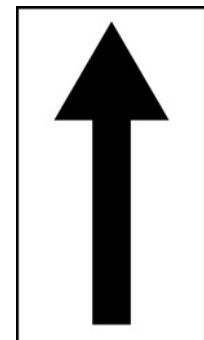

Lifting point - Base

	ATTENZIONE ! Prima di aprire togliere tensione	ATTENTION ! Enlever l'alimentation électrique avant d'ouvrir
ACHTUNG ! Vor öffnen des gehäuses hauptschalter ausschalten	CAUTION ! Disconnect electrical supply before opening	ATENCIÓN ! Cortar la corriente antes de abrir el aparato

**Electrical warning
Adjacent to the master switch**

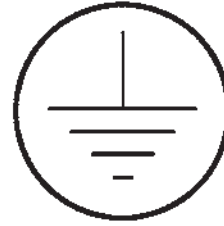

Grounding connection on the electrical board, adjacent to the connection

ATTENZIONE
INSERIRE LE RESISTENZE DI RISCALDAMENTO OLIO ALMENO 12 ORE PRIMA DI OGNI AVVIAMENTO (SE PREVISTE)
PRIMA DELLA MESSA IN TENSIONE ASSICURARSI CHE LE VITI DEI CIRCUITI ELETTRICI SIANO SERRATE COMPLETAMENTE

WARNING
ENERGIZE THE CRANKCASE HEATER FOR AT LEAST 12 HOURS BEFORE EACH STARTING (IF FITTED)
BEFORE TIGHTENING-UP, TO TIGHTEN ALL TERMINAL SCREWS ESPECIALLY THOSE IN MAIN CIRCUIT

WARNUNG
OLSUMPFHEIZUNG (FALLS VORHANDEN) 12 STUNDEN VOR DEM START EINSCHALTEN VOR INBETRIEBNAHME ALLE SCHRAUBENVERBINDUNGEN NACHZIEHEN, BESONDERS DIE ELEKTRISCHEN ANSCHLUSSE

ATTENTION
ALIMENTER ELECTRIQUEMENT LA RESISTANCE DE CARTER AU MOINS 12 HEURES AVANT CHAQUE DEMARRAGE (SI MONTE SUR LE PRODUIT)
AVANT DE DEMARRER LA MACHINE, VERIFIER LE SERRAGE DE TOUTES LES BORNES A VIS, SPECIALMENT DANS LE BOITIER ELECTRIQUE

ATENCIÓN
ATENCIÓN! ALIMENTAR ELECTRICAMENTE LA RESISTENCIA DE CARTER AL MENOS 12 HORAS ANTES DE CADA PUESTA EN MARCHA (SI ESTA EQUIPADA EN LA UNIDAD)
ANTES DE LA PUESTA EN MARCHA, COMPROBAR QUE LOS BORNES ESTÁN BIEN APRETADOS, ESPECIALMENTE EN EL CUADRO ELECTRICO

035B00057-000 MADE IN ITALY

Start-up warning - Outside the door of the electrical board



Read the instruction on the electrical board

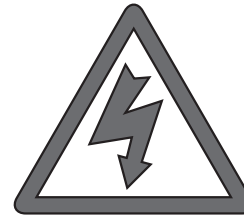

On voltage adjacent to the master switch

CERTIFICATO DI COLLAUDO PRODUZIONE PRODUCTION TEST CERTIFICATE		
DESIGNAZIONE	TIPO	SERIE LOTTO PRODUZ.
DESIGNATION	TYPE	SERIAL NUMBER/PRODUCTION LOT
PROG. COLL. CHECK NUMBER	DESCRIZIONE DEI TEST DESCRIPTION OF QUALITY CHECK	TIMBRO OPERAT. INSP. CODE
1	VERIFICA ASSEMBLAGGIO CHECK ASSEMBLY PARTS	
2	VERIFICA VISIVA CABLAGGIO COLLEG. ELETTRICI E CONNESSIONE CHECK WIRING CONNECTION	
3	VUOTO E CARICA VACUUM AND REFRIGERANT CHARGE	
4	VERIFICA CON CERCAFUOGHE TENUTA CIRCUITO FRIGORIFERO REFRIGERANT LEAK TEST	
5	TEST SICUREZZA ELETTRICA SAFETY TEST	
6	PROVE FUNZIONALI CON RILIEVI TEMPERATURE PRESSIONI RUMORI FUNCTIONAL AND RUN TEST, NOISE TEST	
7	VERIFICA INTERVENTI SICUREZZE PRESSIONE E TEMPERATURA CHECK SAFETY DEVICES	
8	VERIFICA VISIVA SONDE VISUAL CHECK SENSOR	
9	VERIFICA TENUTA CIRCUITO IDR. E FUNZIONAMENTO POMPA (SU PACK) HYDRAULIC CIRCUIT TEST (PUMP CHECK ONLY FOR PACK UNIT)	
10	VERIFICA MONTAGGIO ACCESSORI (SE PREVISTI) E DOCUMENTAZIONE CHECK ACCESSORIES DOCUMENTATION	
11	CONTROLLO ESTETICO FINALE TENUTA CIRCUITO E PULIZIA VISUAL CHECK/LEAK FINAL TEST AND CLEANING ASPECTS	

Final Test Certificate - Inside the external door



Warning - safety valves' vents

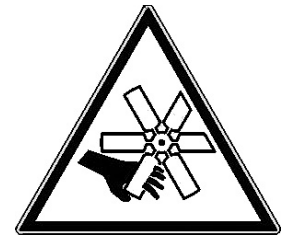

Fan Danger

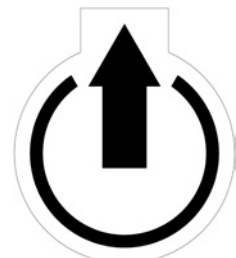
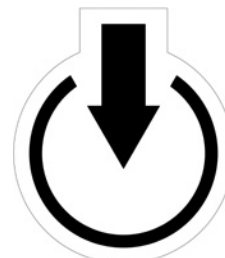

Fitting identification - Adjacent to fittings

2.8 Safety regulations

Refrigerant data	Safety data: R410A
Toxicity	Low
Contact with skin	If sprayed, the refrigerant is likely to cause frost burns. If absorbed by the skin, the danger is very limited; it may cause a slight irritation, and the liquid is degreasing. Unfreeze the affected skin with water. Remove the contaminated clothes with great care - in the presence of frost burns, the clothes may stick to the skin. Wash with plenty of warm water the affected skin. In the presence of symptoms such as irritation or blisters, obtain medical attention.
Contact with eyes	Vapours do not cause harmful effects. The spraying of refrigerant may cause frost burns. Wash immediately with a proper solution or with tap water for at least 10 minutes, and then obtain medical attention.
Ingestion	Very unlikely - should something happen, it will cause frost burns. Do not induce vomiting. Only if the patient is conscious, wash out mouth with water and give some 250 ml of water to drink. Then, obtain medical attention.
Inhalation	R410A: remarkable concentrations in the air may have an anaesthetic effect, up to fainting. The exposure to considerable amounts may cause irregular heartbeat, up to the sudden death of the patient. Very high concentrations may result in the risk of asphyxia, due to the reduction in the oxygen percentage in the atmosphere. Remove the patient to fresh air and keep warm and at rest. If necessary, give oxygen. In case of breathing difficulties or arrest, proceed with artificial respiration. In case of cardiac arrest, proceed with cardiac massage. Then, obtain medical attention.
Recommendations	Semiotics or support therapy is recommended. Cardiac sensitisation has been observed that, in the presence of circulating catecholamines such as adrenalin, may cause cardiac arrhythmia and accordingly, in case of exposure to high concentrations, cardiac arrest.
Prolonged exposure	R410A: a study on the effects of exposure to 50,000 ppm during the whole life of rats has identified the development of benign testicle tumour. This situation should therefore be negligible for personnel exposed to concentrations equal to or lower than professional levels.
Professional levels	R410A: Recommended threshold: 1000 ppm v/v - 8 hours TWA.
Stability	R410A: Not specified
Conditions to avoid	Do not use in the presence of flames, burning surfaces and excess humidity.
Hazardous reactions	May react with sodium, potassium, barium and other alkaline metals. Incompatible substances: magnesium and alloys with magnesium concentrations > 2%.
Hazardous decomposition products	R410A: Halogen acids produced by thermal decomposition and hydrolysis.

General precautions	Do not inhale concentrated vapours. Their concentration in the atmosphere should not exceed the minimum preset values and should be maintained below the professional threshold. Being more weighty than the air, the vapour concentrates on the bottom, in narrow areas. Therefore, the exhaust system must work at low level.
Respiratory system protection	If you are in doubt about the concentration in the atmosphere, it is recommended to wear a respirator approved by an accident-prevention Authority, of the independent or oxygen type.
Storage	Cylinders must be stored in a dry and fresh place, free from any fire hazard, far from direct sunlight or other sources of heat, radiators etc. Keep a temperature below 50 °C.
Protective clothing	Wear overalls, protective gloves and goggles or a mask.
Accidental release measures	It is important to wear protective clothing and a respirator. Stop the source of the leak, if you can do this without danger. Negligible leaks can be left evaporating under the sun, providing that the room is well ventilated. Considerable leaks: ventilate the room. Reduce the leak with sand, earth or other absorbing substances. Make sure that the liquid does not channelled into gutters, sewers or pits where the vapours are likely to create a stuffy atmosphere.
Disposal	The best method is recovery and recycling. If this method is not practicable, dispose according to an approved procedure, that shall ensure the absorption and neutralization of acids and toxic agents.
Fire fighting information	R410A: Not flammable in the atmosphere.
Cylinders	The cylinders, if exposed to fire, shall be cooled by water jets; otherwise, if heated, they may explode.
Protective fire fighting equipment	In case of fire, wear an independent respirator and protective clothing.

Lubricant oil data	Safety data: Polyester oil (POE)
Classification	Not harmful.
Contact with skin	May cause slight irritation. Does not require first aid measures. It is recommended to follow usual personal hygiene measures, including washing the exposed skin with soap and water several times a day. It is also recommended to wash your overalls at least once a week.
Contact with eyes	Wash thoroughly with a suitable solution or tap water.
Ingestion	Seek medical advice immediately.
Inhalation	Seek medical advice immediately.
Conditions to avoid	Strong oxidising substances, caustic or acid solutions, excess heat. May corrode some types of paint or rubber.
Protection of the respiratory system	Use in well ventilated rooms.
Protective clothing	Always wear protective goggles or a mask. Wearing protective gloves is not mandatory, but is recommended in case of prolonged exposure to refrigerant oil.
Accidental release measures	It is important to wear protective clothing and, especially, goggles. Stop the source of the leak. Reduce the leak with absorbing substances (sand, sawdust or any other absorbing material available on the market).
Disposal	The refrigerant oil and its waste will be disposed of in an approved incinerator, in conformity with the provisions and the local regulations applicable to oil waste.
Fire fighting information	In the presence of hot liquid or flames, use dry powder, carbon dioxide or foam. If the leak is not burning, use a water jet to remove any vapours and to protect the personnel responsible for stopping the leak.
Cylinders	The cylinders exposed to a fire will be cooled with water jets in case of fire.
Fire fighting protective equipment	In case of fire, wear an independent respirator.

3 TRANSPORT, LIFTING AND POSITIONING

Refrigerators are supplied assembled (apart from standard antivibrating rubber supports, that will be installed on site). The equipment are full of refrigerant and oil, in the quantity required for a proper operation.

3.1 Inspection

When the unit is delivered, it is recommended to check it carefully and to identify any damage occurred during transportation. The goods are shipped ex-factory, at the buyer's risk. Check that the delivery includes all the components listed in the order.

In case of damage, note it down on the carrier's delivery note and issue a claim according to the instructions provided in the delivery note.

In the presence of any serious damage, that does not affect the surface only, it is recommended to inform manufacturer immediately.

Please note that manufacturer may not be held liable for any damage to the equipment during transportation, even though the carrier has been appointed by the factory.

3.2 Lifting

The unit must be lifted by using the hooks inserted into the relevant eyebolts (see the figure).

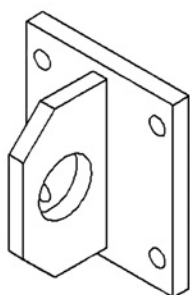

It is recommended to use a spacer to prevent cables from damaging the unit (see the figure).

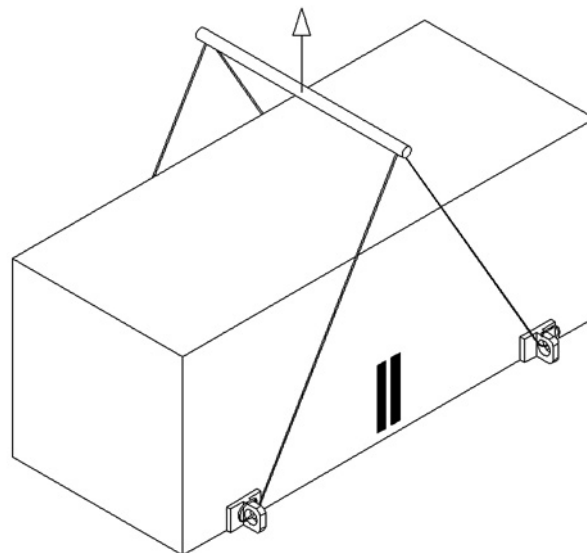

Before positioning the unit, make sure that the place of installation is appropriate and sturdy enough to hold the weight and to withstand the stress caused by the operation of the whole assembly.



Do not displace the unit on rollers, and do not lift it with a lift truck.

**Unit must be lifted carefully.
To lift unit slowly and regularly.**

To lift and displace the unit:

- Insert and secure eyebolts into the holes marked on the frame.
- Insert spacer between cables.
- Hook near the barycentre of the unit.
- The cables must be long enough to form, if tensioned, an angle of at least 45° with respect to the horizontal plane.



For lifting operations, use only tools and material fit for this purpose, in accordance with accident-prevention regulations.



During the lifting and handling of the unit, be careful not to damage the finned pack of the coils positioned on the sides of the unit. The sides of the unit must be protected by cardboard or plywood sheets.



It is recommended not to remove the protective plastic envelope, that should prevent scraps from penetrating into the appliance and any damage to the surfaces, until the unit is ready for operation.



The lifting eyebolts protrude from the base of the unit; it is therefore recommended to remove them once the unit has been lifted and positioned, if in your opinion they are likely to become a source of hazard and injury.

The eyebolts must be mounted on the unit whenever it shall be displaced and then lifted again.

3.3 Anchoring

It is not essential to secure the unit to the foundations, unless in areas where there is a serious risk of earthquake, or if the appliance is installed on the top of a steel frame.

3.4 Storage

When the unit is to be stored before installation, adopt a few precautions to prevent any damage or risk of corrosion or wear:

- plug or seal every single opening, such as water fittings
- do not store the appliance in a room where the temperature exceeds 50 °C for the units using R410A and, if possible, do not expose to direct sunlight
- minimum storage temperature is -25 °C
- it is recommended to store the unit in a roof where traffic is minimized, to prevent the risk of accidental damage
- the unit must not be washed with a steam jet
- take away and leave to the site manager all the keys providing access to the control board

Finally, it is recommended to carry out visual inspections at regular intervals.

Installation

4 INSTALLATION

4.1 Positioning of the unit



Before installing the unit, make sure that the structure of the building and/or the supporting surface can withstand the weight of the appliance. The weights of the units are listed in Chapter 8 of this manual.

These units have been designed for outdoor installation on a solid surface. Standard accessories include antivibrating rubber supports, that must be positioned under the base.

When the unit is to be installed on the ground, it is necessary to provide a concrete base, to ensure a uniform distribution of the weights.

As a general rule, no special sub-bases are required. However, if the unit is to be installed on the top of inhabited rooms, it is advisable to rest it on spring shock absorbers (optional), that will minimise the transmission of any vibration to the structures.

To choose the place of installation of the unit, bear in mind that:

- the longitudinal axis of the unit must be parallel to the direction of prevailing winds, so as to ensure a uniform distribution of the air on finned exchangers
- the unit must not be installed near boilers' vent pipes
- the unit must not be installed leeward with respect to sources of air contaminated by greases, such as, for example, the outlets to kitchen exhaust hoods into the atmosphere. Otherwise, the grease is likely to deposit on the fins of the refrigerant / air exchangers, and would fix every type of atmospheric impurity, resulting in the quick clogging of the exchangers
- the unit must not be installed in areas subject to considerable snow falling
- the unit must not be installed in areas subject to flooding, under gutters etc.
- the unit must not be installed in air shafts, narrow courts or other small places, where the noise may be reflected by the walls or the air ejected by fans may short-circuit itself on refrigerant/air heat exchangers or condenser
- the place of installation must be have all the necessary spaces for air circulation and maintenance operations (see Chapter 8).

4.2 Spring Isolator Installation

- Prepare the base, that must be flat and plane.
- Lift the appliance and insert shock absorbers as follows:

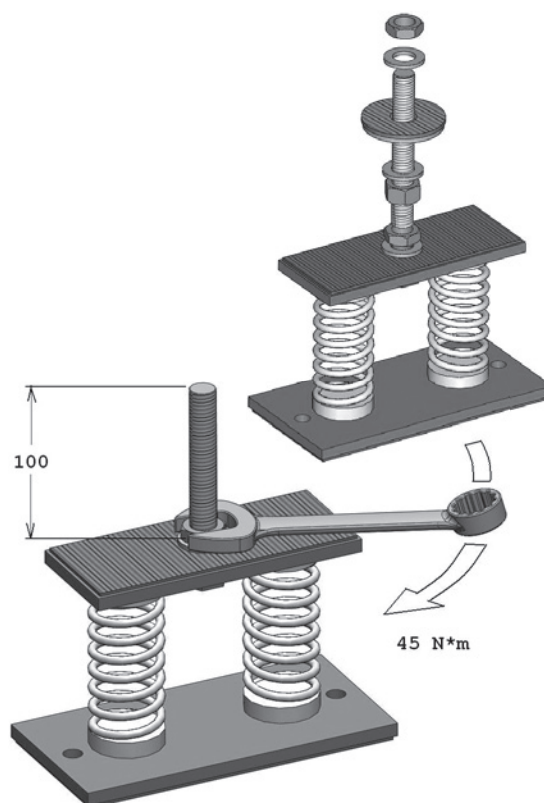

- 1) Proceed to assemble the jack components. Fit the jack in the threaded housing on the upper plate of the antivibration mount.

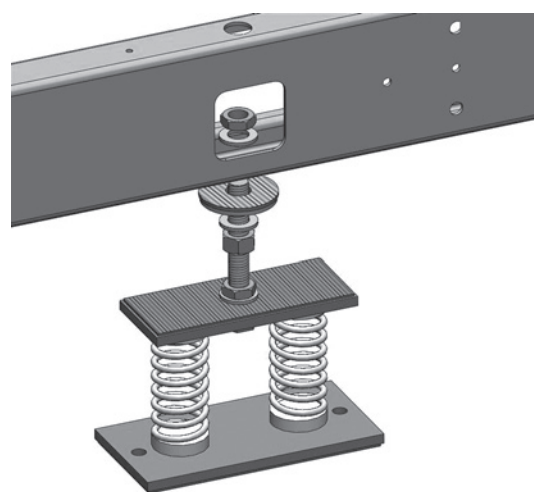

- 2) Fit the jack mounted on the antivibration mount in the hole in the machine base.

4.3 External Water Circuit

The flow switch and the filter water, although not included in the supply, must always be fitted such as plant components.

Their installation is mandatory for warranty.



The external water circuit shall guarantee a constant water flow rate through the circulating refrigerant/water heat exchanger (evaporator) under steady operating conditions and in case of a load variation.

The circuit shall be composed by the following elements:

- A circulation pump which can ensure the necessary flow rate and head.
- The total content of the primary water circuit shall never be lower than 2.5 lt/kW in terms of refrigerating capacity. If the total water volume in the primary circuit should be unable to reach such a value, an additional heat-insulated storage tank should be installed. This tank is intended to avoid any repetitive start of the compressor.
- A membrane expansion tank complete with a safety valve and a drain which shall be visible.



The expansion tank shall be dimensioned in such a way that it can absorb a 2% expansion of the total volume of the water in the plant (exchanger, pipelines, uses and storage tank, if available). The expansion tank shall never be insulated when the circulating fluid is not flowing through it.

A differential pressure switch is mounted as a standard. It will stop the unit whenever it senses a load loss through the heat exchanger which may result in a flow rate problem.

In addition:

- Install on/off valves (accessory) on the lines at the inlet and outlet of the manifolds of the exchangers (evaporator).
- Arrange a by-pass complete with an on/off valve between the manifolds of the heat exchangers.
- Arrange air vent valves at the high points of the water lines.
- Arrange drain points complete with plugs, clocks, etc. in the proximity of the low points of the water lines.
- Insulate the water lines to prevent the heat from blowing back into the unit.

AQVL-AQVH 85-140 Hydraulic System Basic

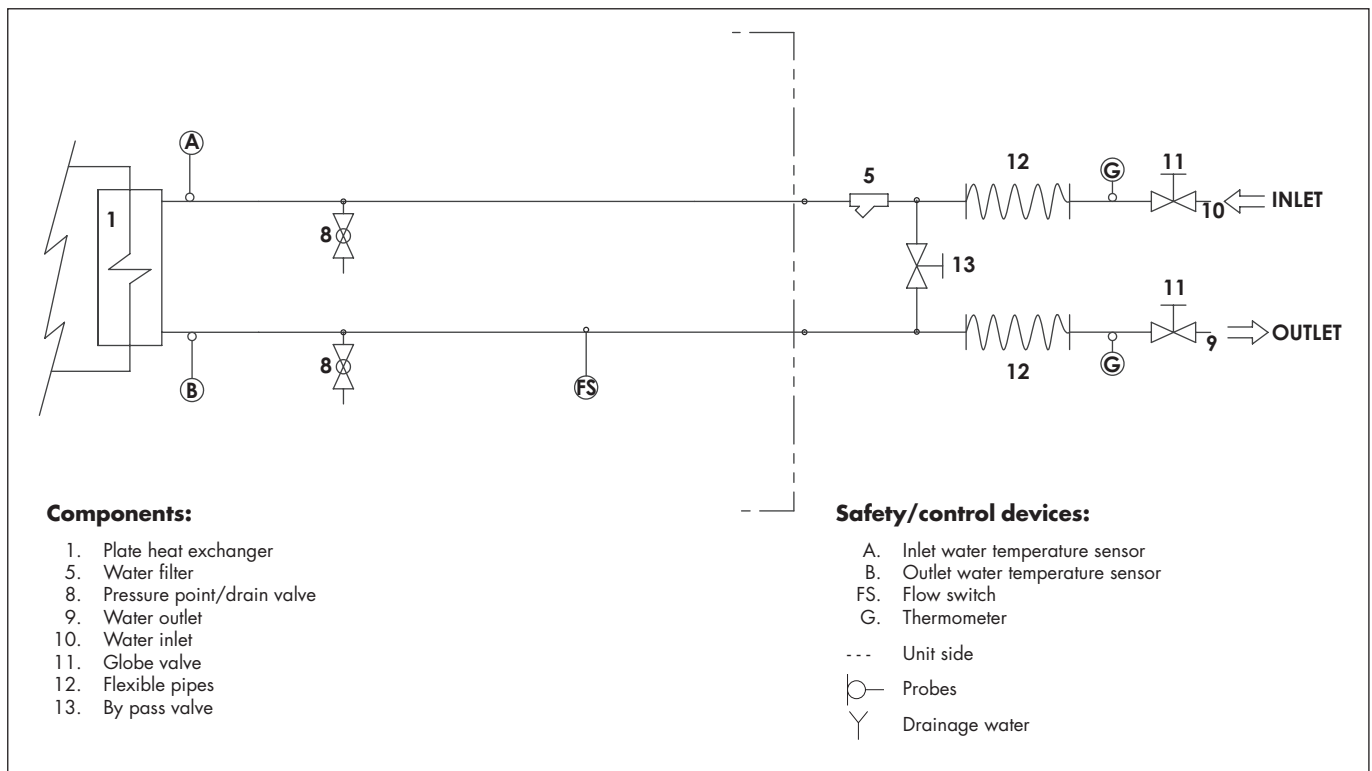

AQVL-AQVH 85-140 Hydraulic System 1P

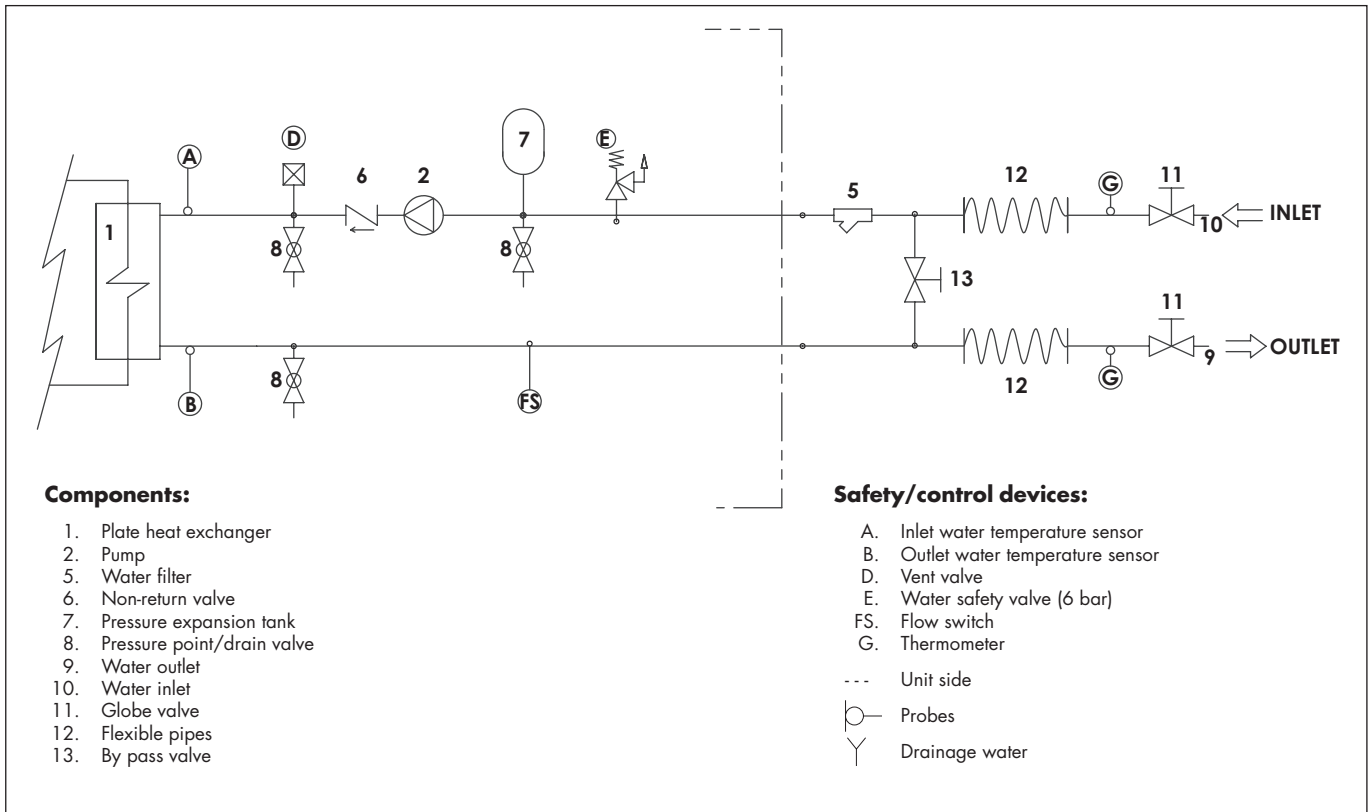

AQVL-AQVH 85-140 Hydraulic System 2P

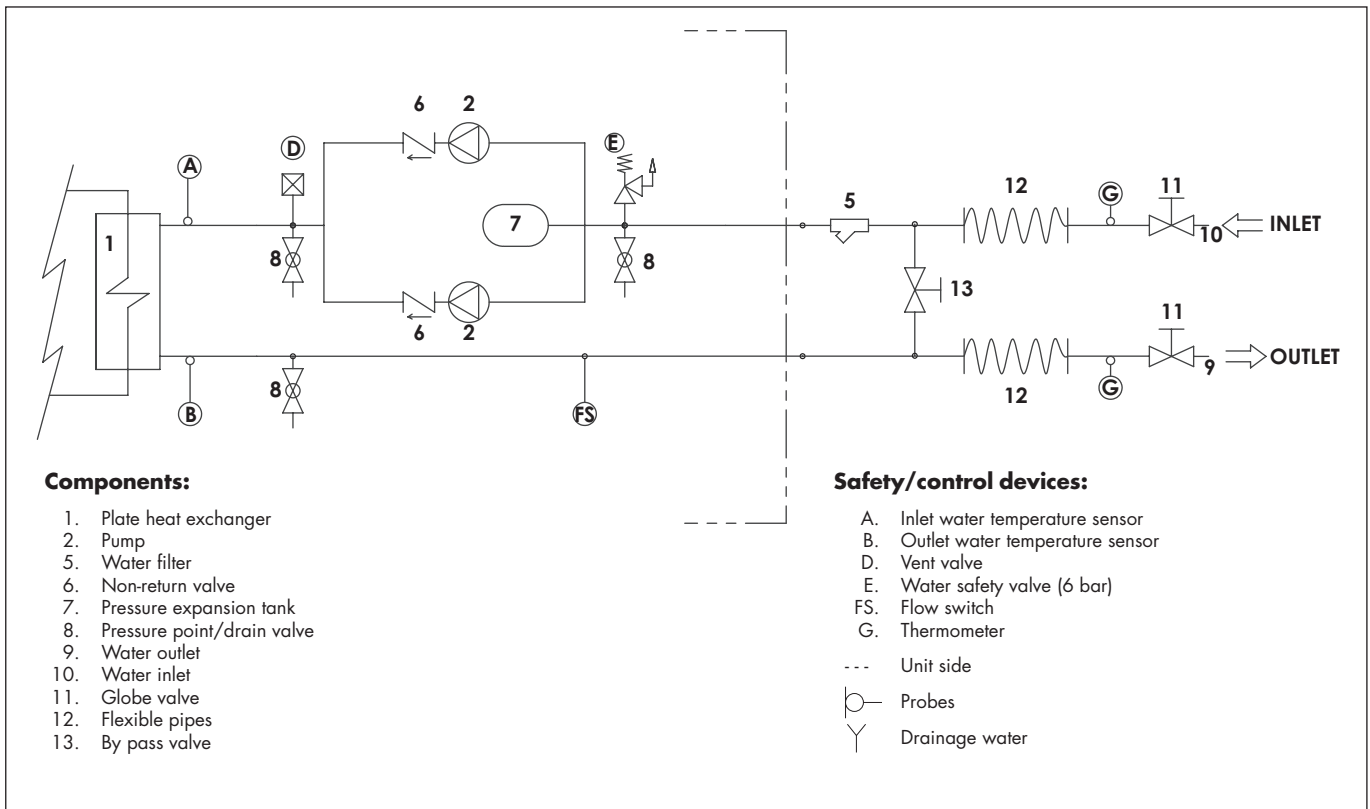

AQVL-AQVH 85-140 Hydraulic System 3P

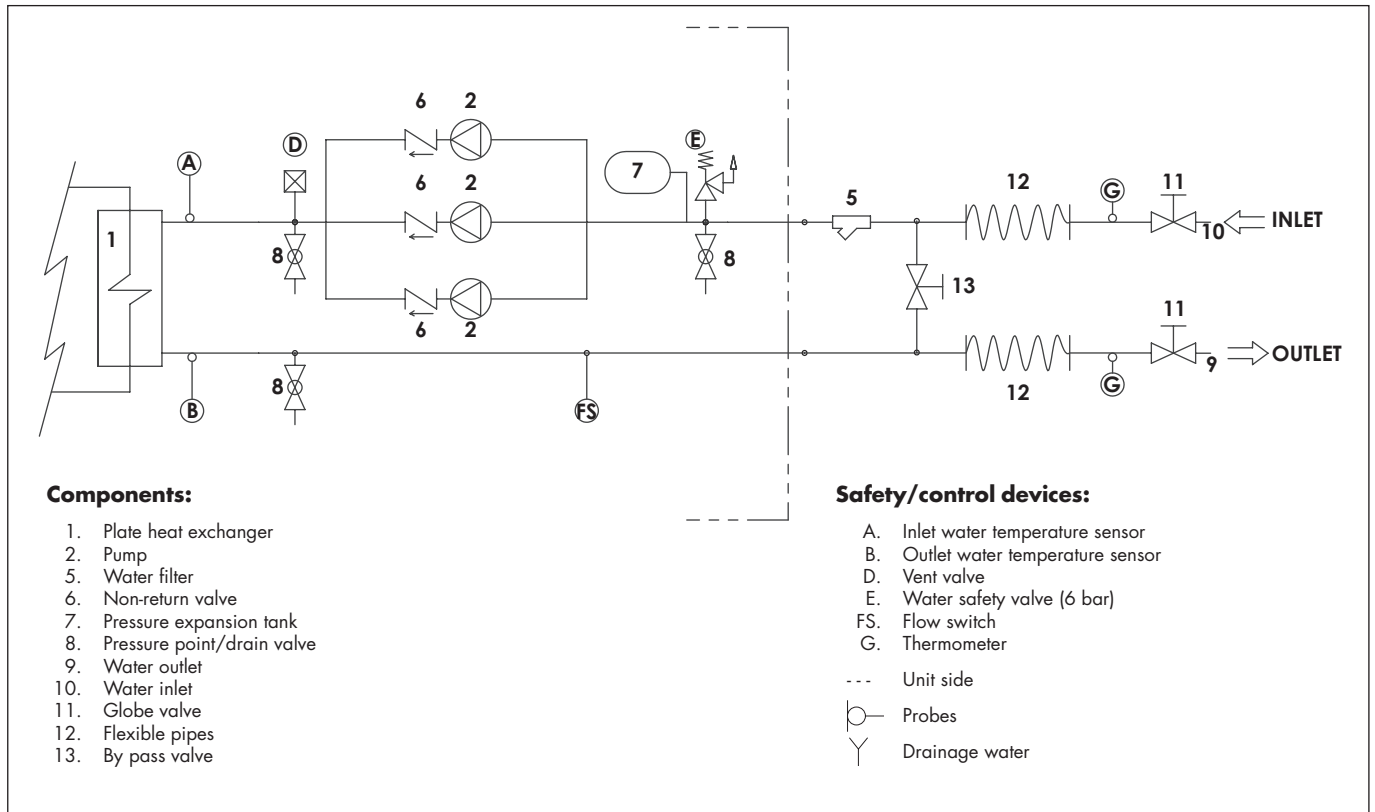

AQVL-AQVH 85-140 Hydraulic System 1P+T

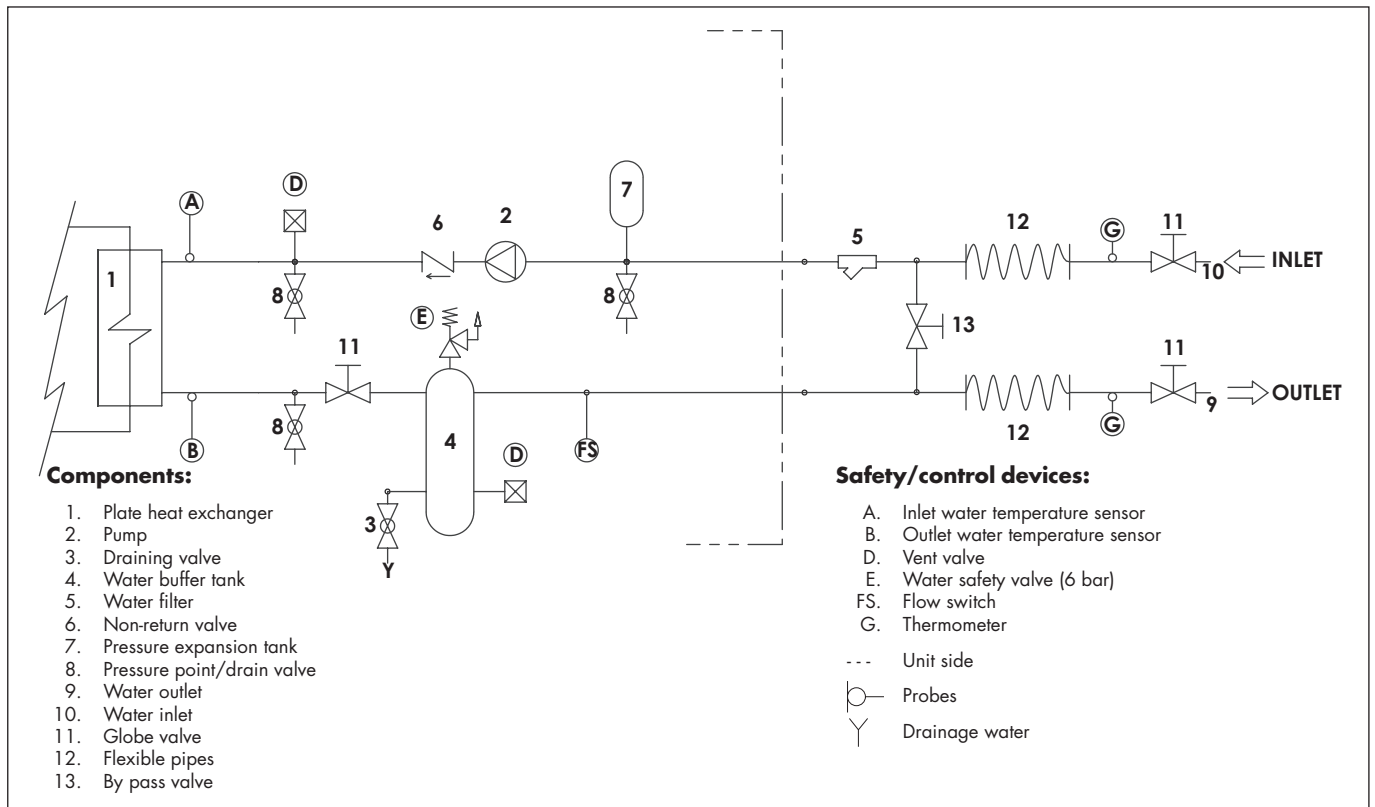

Installation

AQVL-AQVH 85-140 Hydraulic System 2P+T

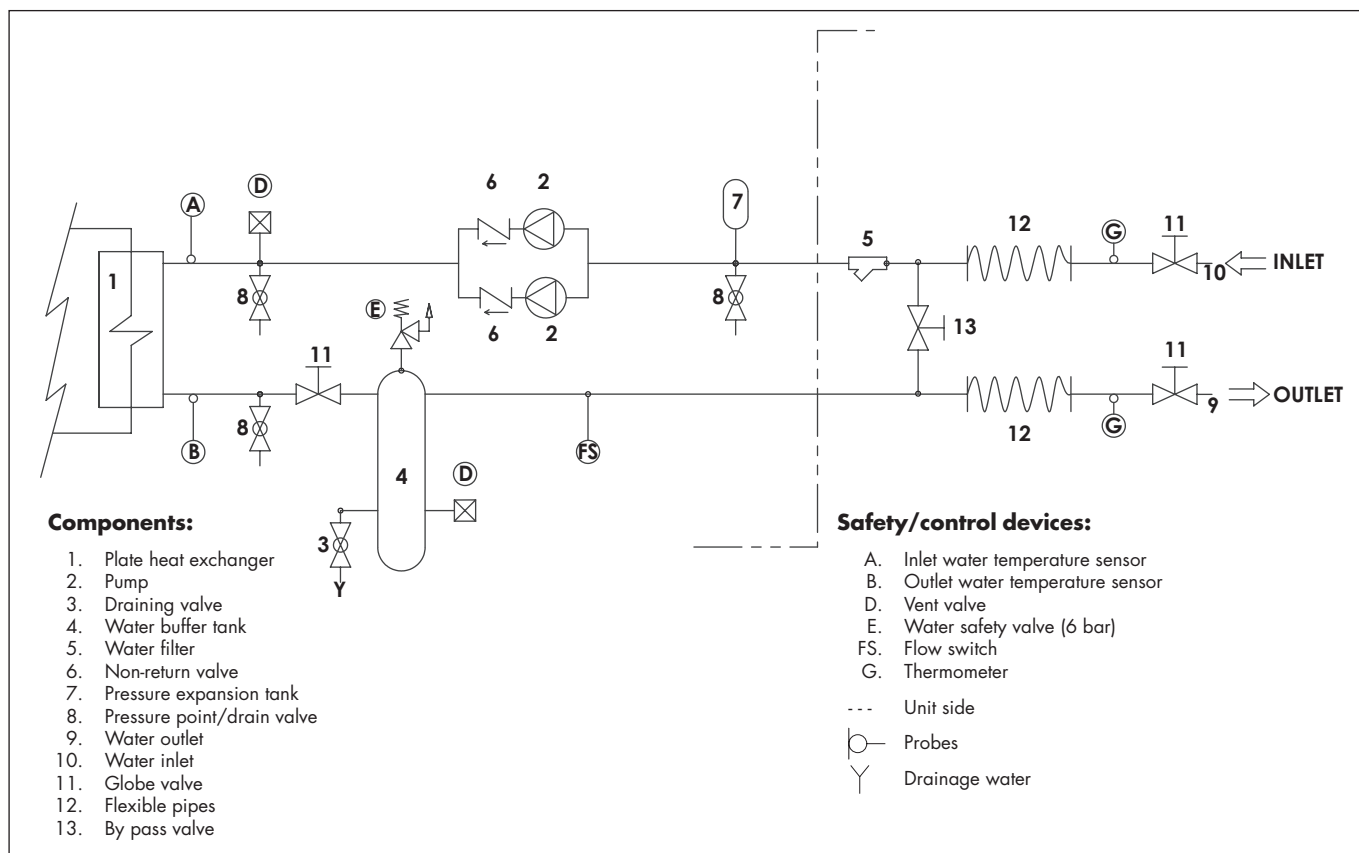

4.4 Water connections



The attachments at the water inlet and outlet shall be connected in compliance with the instructions which can be found on the labels in the proximity of the attachments.

Connect the water lines of the plants with the attachments of the unit whose diameters and positions are shown by Chapter 8.

4.5 Defrost water drainage (only for AQVH units)

When heat pump units work in heating mode, during defrosting cycles, they may discharge water from the base. This is why the units should be installed at least 200 mm above the floor level, so as to allow the free drainage of waste water, without the risk of producing ice banks.

The heat pump units must be installed in positions where the defrosting water cannot create any damage.

4.6 Power supply



Before carrying out any operations on the electrical system, make sure that the unit is deenergised.



It is important that the appliance is grounded.



The company in charge of the installation shall conform to the standards applicable to outdoor electrical connections.

The manufacturer may not be held liable for any damage and/or injury caused by failure to comply with these precautions.

The unit conforms to EN 60204-1.

The following connections shall be provided:

- A 3-phase and grounding connection for the power supply circuit.
- The electrical distribution system shall meet the power absorbed by the appliance.
- The disconnecting and magnetothermal switches must be sized to control the starting current of the unit.
- The power supply lines and the insulation devices must be designed in such a way that every line independent.

Installation

- It is recommended to install differential switches, to prevent any damage caused by phase drops.
- The fans and compressors are supplied through contactors controlled from the control panel.
- Each motor is provided with an internal safety thermal device and external fuses.
- The power supply cables must be inserted into dedicated openings on the front of the unit, and they will enter the electrical board through holes drilled on the bottom of the board.

4.7 Electrical connections

The unit must be installed on site according to the Machinery Directive (98/37/EC), the Low Voltage Directive (2006/95/EC), the Electromagnetic Interference Directive (89/336/EC) and the usual procedures and standards applicable in the place of installation. The unit must not be operated if its installation has not been carried out according to the instructions provided in this manual.

The power supply lines must consist of insulated copper conductors, dimensioned for the maximum absorbed current.

4.8 Connecting plate-type evaporator temperature sensors

AQVL and AQVH units are provided with fittings for hydraulic connections between heat exchangers

and plant. Each fittings is complete with sensor well to fasten temperature sensor (BT-IN and BT-OUT). Fittings are supplied separate and must be mounted during the installation of the unit, as explained in the instruction below.



Before connecting the power supply lines, check that the available voltage value does not exceed the range specified in the Electric Data (Chapter 8).

For 3-phase systems, check also that the unbalance between the phases does not exceed 2%. To perform this check, measure the differences between the voltage of each phase couple and their mean value during operation. The maximum % value of these differences (unbalance) must not exceed 2% of the mean voltage.

If the unbalance is unacceptable, contact the Energy Distributor to solve this problem.



Supplying the unit through a line whose unbalance exceeds the permissible value will automatically void the warranty.

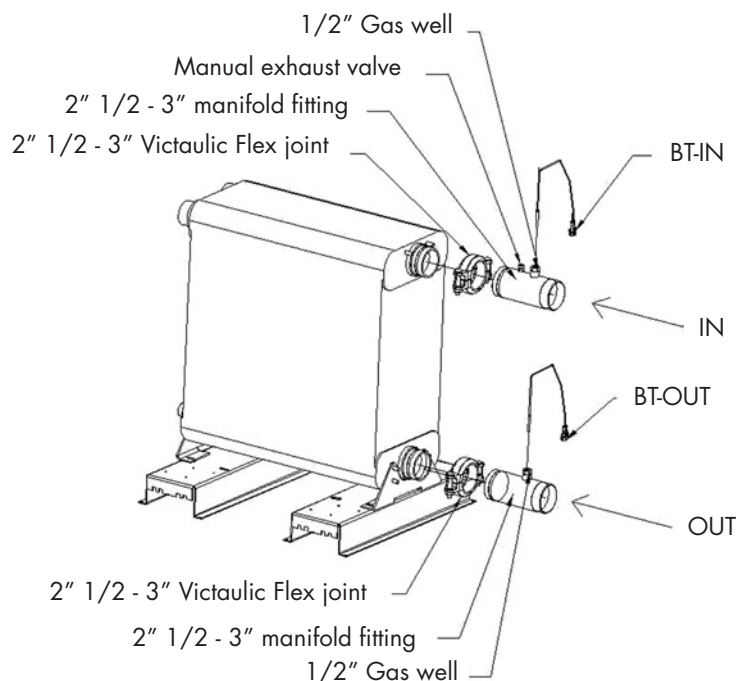

AQVL/AQVH/AQVC Version – Electrical Connections

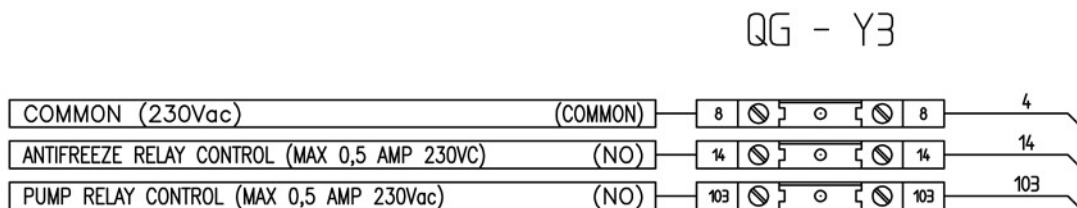
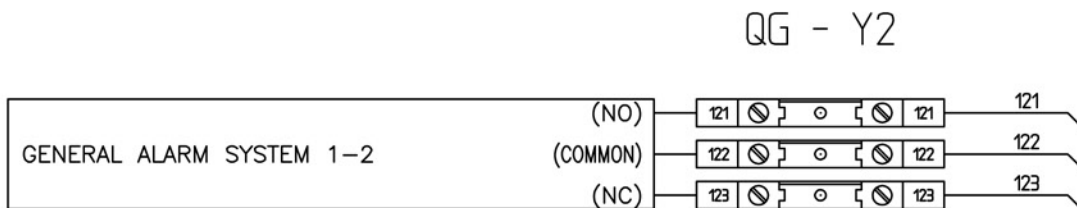
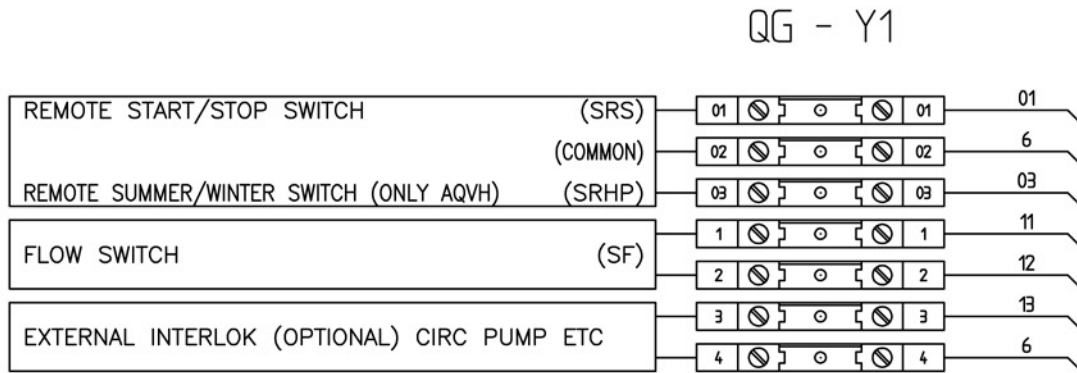

MORSETTIERA UTENTE / USER TERMINALS

4.9 Microchannel type condenser coils

On cooling only unit fitted with microchannel type condenser coils, it is necessary to remove the fixation screws, once unit is installed, as shown in figure below.

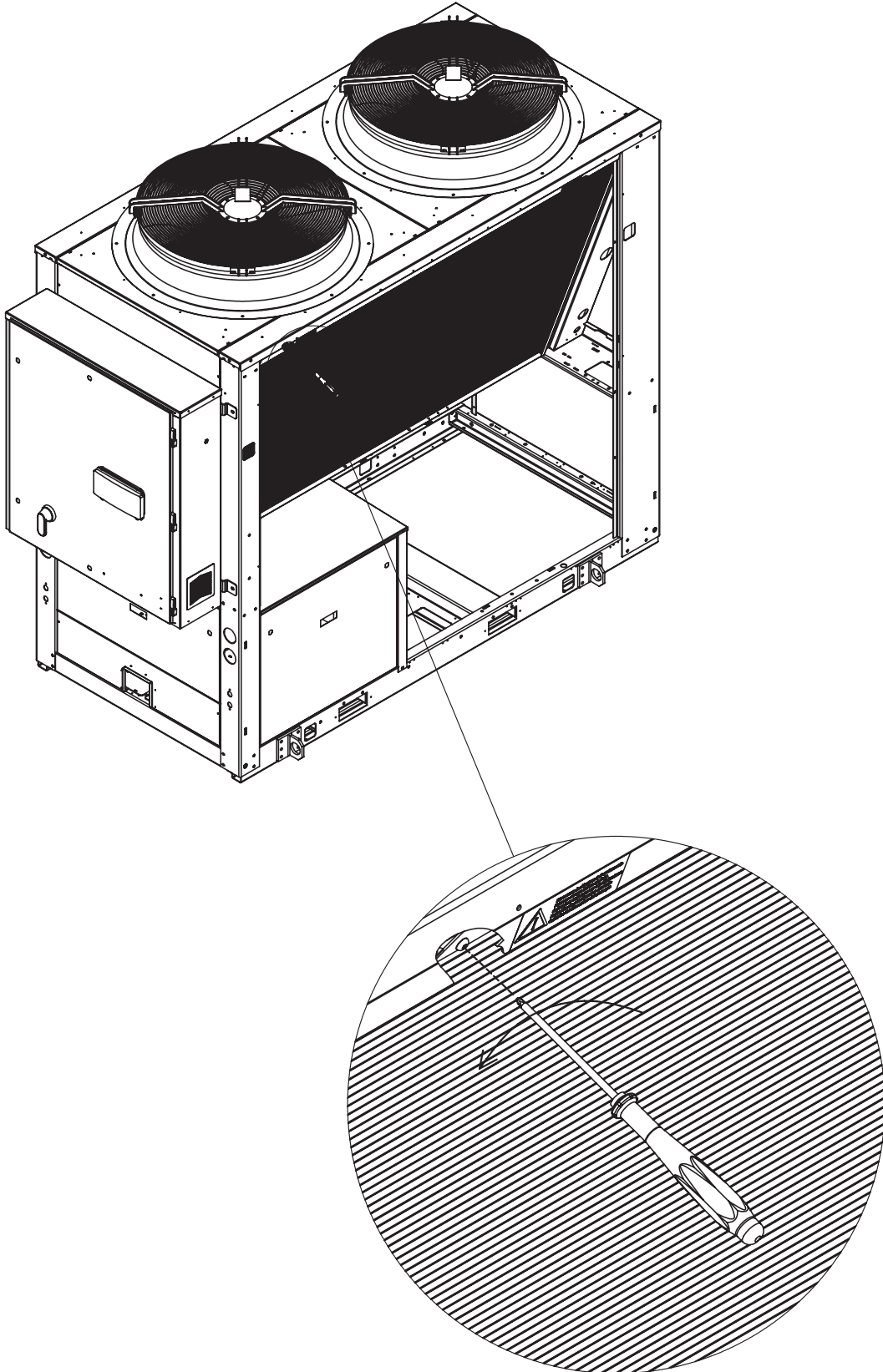

5 START-UP



The unit must be started for the first time by personnel suitably trained by one Authorised Service Centre. Failure to meet this requirement will immediately void the warranty.



The operations carried out by authorised personnel are limited to the start-up of the unit, and do not include any other operation on the plant, such as, for example, electrical and hydraulic connections etc. All the other operations before start-up, including oil pre-heating for at least 12 hours, must be performed by the Installer.

5.1 Preliminary check

The checks listed below shall be performed before starting the unit and before the arrival of the personnel authorised.

- Check the section of power supply and grounding cables; make sure that terminals are tightened and check the correct operation of contactors, with the main switch open.
- Check that any voltage and phase variation in the power supply does not exceed the prefixed thresholds.
- Connect the contacts of the flow switch and the thermal relay of the pump and of the other devices (if any), to terminals 1-2 and 3-4, respectively.
- Check that the components of the external water circuit (pump, user equipment, filters, power supply tank and reservoir, if any) have been installed properly, and according to the manufacturer's instructions.
- Check the filling of the hydraulic circuits, and make sure that the fluid circulation is correct, without any trace of leaks and air bubbles. If you use ethylene glycol as antifreeze, check that its percentage is correct (do not exceed 35% glycol percentage).
- Check that the direction of rotation of the pumps is correct, and that fluids have been circulating for at least 12 hours for both pumps. Then, clean the filters on the suction side of the pumps.
- Adjust the liquid distribution network in such a way that the flow rate is within the specified range.
- Check that the water quality is up to the specifications.
- Check that oil heaters, if any, have been turned on at least 12 hours before.

5.2 Start-up

Start-up sequence:

- Turn on the Main switch (at least 12 hours before).
- Check that the oil in the compressor has reached the requested temperature (the minimum temperature outside the pan must be approx. 40°C) and that the auxiliary control circuit is energised.
- Check the operation of all the external equipment, and make sure that the control devices of the plant are properly calibrated.
- Start the pump and check that the water flow is correct.
- Set the desired fluid temperature on the control board.
- Start the appliance (see Chapter 6).
- Check the correct direction of rotation of compressors. Scroll compressors cannot compress the refrigerant when they rotate in the opposite direction. To make sure that they are rotating in the correct direction, simply check that, just after the start-up of the compressor, the pressure drops on the LP side and rises on the HP side. Furthermore, if a scroll compressor rotate in the opposite direction, there is a considerable rise in the sound level of the unit, as well as in a dramatic reduction of current absorption compared to normal values. In case of wrong rotation, the scroll compressor can be definitely damaged. Phase monitor is assembled in the unit as a standard to prevent wrong compressors rotation.
- After about 15 minutes of operation check that there are no bubbles, through the sight glass on the liquid line.



The presence of bubbles may indicate that a part of the refrigerant charge has been released in one or more points. It is important to remove these leaks before proceeding.

- Repeat the start-up procedure after removing the leaks.

5.3 Checking the operation

Check the following:

- The temperature of the water entering the evaporator.
- The temperature of the water leaving the evaporator.
- The level of the water flow rate in the evaporator, if possible.

Start-up

- The current absorption upon the start of the compressor and in case of stabilised operation.
- The fan's current absorption.

Check that the condensing and evaporation temperatures, during operation at high and low pressure detected by the pressure gauges of the refrigerant, are within the following range:
(On the units not provided with HP/LP pressure gauges for the refrigerant, connect a pressure gauge to the Schrader valves on the refrigeration circuit).

HP side	Approx. 15 to 21°C above the temperature of the air entering the condenser, for R410A units.
LP side	Approx. 2 to 4°C below the temperature of the leaving chilled water, for R410A units.

5.4 Delivery to the customer

- Train the user according to the instructions provided in Section 6.

6 GENERAL INFORMATION

Introduction

This document contains the information and the operating instructions for AQVL-AQVH-AQVC 4 compressors & electronic control.

This information is for the after-sales service and the production operators, for the end-of-line testing.

Main characteristics

- microprocessor control
- user-friendly keyboard
- proportional and integral control of the return water temperature (RWT)
- hysteresis control of the leaving water temperature (LWT)
- access code to enter the Manufacturer's Level
- access code to enter the Assistance Level
- alarm and LED
- backlighted LCD
- pump-Down logic (start-stop)
- rotation of the compressor operation
- oil return function
- night mode (or Low Noise) control
- counting of the pump/compressors' hours of operation
- display of discharge and suction pressure values
- display of temperature sensor
- history of stored alarms (option)
- programming of different setpoints with 4 ranges of time/setpoint.

The following accessories can be also connected:

- Real Time Clock Memory Card: alarm history and programming of different setpoints with ranges of time
- serial communication RS485 card; to connect the "Chiller Control" to a BMS network
- remote display terminal
- wire remote control.

6.1 Control of AQVL-AQVH-AQVC with 4 compressors. The "CHILLER CONTROL" system

The AQVL-AQVH machines with 4 scroll compressors are provided with a microprocessor card which is fully programmed by default for the control of a chiller of cold only type with 2 circuits, 2 compressors per circuit, a high-pressure transducer per circuit.

The control system consists of:

Keyboard & Display Terminal

General information

The figure shows the terminal with the front door open.

It is provided with a LCD 4 lines x 20 columns, keyboard and microprocessor-controlled LED's, so as to allow the programming of the control parameters (setpoint, differential bands, alarm thresholds) and themain operations to be carried out by the user.

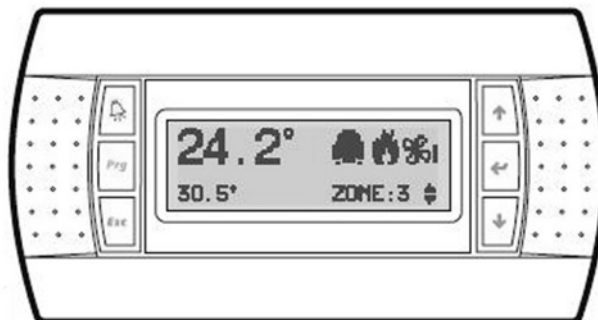

Terminal & Key Board description

The terminal makes it possible to carry out the following operations:

- the initial configuration of the machine
- the change of all the main operating parameters
- the display of the detected alarms
- the display of all the measured quantities

The terminal and the card are connected by a 6-way phone cable.

The connection of the terminal to the basic card is not essential for the normal operation of the controller.



Access to the "display mask" of the machine status.

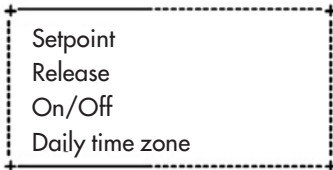

Esc key: allows you to move from one mask to another.



Alarm key: used to display the alarms, to reset them in manual. Press it one to display the mask of the activated alarm, press it again to reset the alarm signal.



Prg-Esc keys: Pressing these keys at the same time, allows you to turn the unit on/off.



Up-Down keys: allows you to set the control parameters' values and to move from one mask to another (not backlit).



Enter key: used to move the cursor inside the masks and to save the values of the set parameters.



Alarm-Enter keys: Press these keys at the same time to enter the "storical alarm" after 1' come back at status machine menu'.

6.2 Display

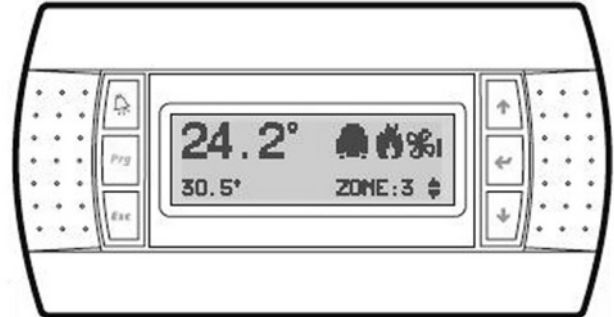

The display is an LCD 4 lines x 20 columns. The quantities and the information about the operation of the unit are alternated in the form of subsequent screens, named.

6.3 Keyboard

Arrows key - Up/Down/Enter

If the cursor is in the top left-hand corner (Home), press the UP/DOWN keys to access the subsequent masks associated to the selected branch. If a mask includes some value setting fields and you press the ENTER key, the cursor will reach these fields.

Once you have reached the quantity setting field, you can modify any value (within the expected limits) by pressing the UP/DOWN keys.

After you have selected the desired value, press the ENTER key again to store it.

■ Alarms



Code	Alarm unit description	Comp. Status	Fan Status	Pump Status	Aut/Man Reset	Delay	Notes
AL00	Automatic Alarm	On	On	On	Aut	0	
AL01	Efficiency alarm CPS	Off	Off	Off	Man	30 sec	
AL02	Flow meter/Interbloc alarm	Off	Off	Off	Man	Parameters	
AL03	Sys 1 High pressure "manual reset".	Off Sys 1	On	On	Man	No	
AL04	Sys 2 High pressure "manual reset"	Off Sys 2	On	On	Man	No	
AL05	Failure of transducer BP B1-SP1-Sys 1	On	Max	On	Auto	10 sec	AQVC only
AL06	Failure of transducer BP Bw-SP2-Sys 2	On	Max	On	Auto	10 sec	AQVC only
AL07	Failure of transducer AP B3-Sys 1-Dp1	On	Max	On	Auto	10 sec	
AL08	Failure of transducer AP B4-Sys 1-Dp2	On	Max	On	Auto	10 sec	
AL09	Failure of sensor B5-Tair	On	Max	On	Auto	10 sec	
AL10	Failure of sensor B6-T LAN	Off	Off	On	Auto	10 sec	
AL11	Failure of sensor B7-Tin	Off	Off	On	Auto	10 sec	
AL12	Failure of sensor B8-Tout	Off	Off	On	Auto	10 sec	
AL13	Failure of sensor B1 Tcoil1	On	On	On	Auto	10 sec	
AL14	Failure of sensor B2 Tcoil2	On	On	On	Auto	10 sec	
AL15	Failure of sensor B3 TANDEM 1	On	Max	On	Auto	10 sec	
AL16	Failure of sensor B4 TANDEM 2	On	Max	On	Auto	10 sec	
AL17	Maintenance of compressor 1	On	On	On	Man	No	
AL18	Maintenance of compressor 2	On	On	On	Man	No	
AL19	Maintenance of compressor 3	On	On	On	Man	No	
AL20	Maintenance of compressor 4	On	On	On	Man	No	
AL21	Pump maintenance	Off	Off	Off	Man	No	
AL22	Failure of clock card	On	On	On	Man	No	
AL23	Thermal switch, compressor 1	Off Comp. 1	On	On	Man	No	
AL23a	Thermal switch, compressor 1-AUTO Reset	Off Comp. 1	On	On	Auto		
AL24	Thermal switch, compressor 2	Off Comp. 2	On	On	Man	No	
AL24a	Thermal switch, compressor 2-AUTO Reset	Off Comp. 2	On	On	Auto		
AL25	Thermal switch, compressor 3	Off Comp. 3	On	On	Man	No	
AL25a	Thermal switch, compressor 3-AUTO Reset	Off Comp. 3	On	On	Auto		
AL26	Thermal switch, compressor 4	Off Comp. 4	On	On	Man	No	
AL26a	Thermal switch, compressor 4 AUTO Reset	Off Comp. 4	On	On	Auto		
AL27	Sys 1 Low pressure alarm	Off Sys 1	On	On	Man	Parameters	
AL27a	Sys 1 Low pressure alarm -AUTO Reset	Off Sys 1	On	On	Auto		
AL28	Sys 2 Low pressure alarm	Off Sys 2	On	On	Man	Parameters	
AL28a	Sys 2 Low pressure alarm -AUTO Reset	Off Sys 2	On	On	Auto		
AL29	Thermal switch, fans	Off	Off	On	Man	No	
AL29a	Thermal switch, fans- AUTO Reset	Off	Off	On	Auto		
AL30	Sys 1 Antifreeze alarm	Off Sys 1	Off	On	Man	No	
AL30a	Sys 1 Antifreeze alarm -AUTO Reset	Off Sys 1	Off	On	Auto		
AL31	Sys 2 Antifreeze alarm	Off Sys 2	Off	On	Man	No	
AL31a	Sys 2 Antifreeze alarm AUTO Reset	Off Sys 2	Off	On	Auto		
AL32	Expansion off line	On	On	On	Man	No	
AL33	Eprom failure	Off	Off	Off	Man	No	

Code	Alarm driver description	CIRC 1-EEV 1 Status	CIRC 2-EEV 2 Status	Notes
AL34	Epron failure driver 1	Off	Run	Man
AL35	Epron failure driver 2	Run	Off	Man
AL36	Cable motor EVV driver 1	Off	On	Man
AL37	Cable motor EVV driver 2	On	Off	Man
AL38	Timeout MOP driver 1	0%	-	Auto
AL39	Timeout MOP driver 2	-	0%	Auto
AL40	Timeout LOP driver 1	100%	-	Auto
AL41	Timeout LOP driver 2	-	100%	Auto
AL42	Low SH driver 1	Run	Run	Auto
AL43	Low SH driver 2	Run	Run	Auto
AL44	Valve open driver 1	Off	Run	Auto
AL45	Valve open driver 2	Run	Off	Auto
AL46	High SH driver 1	Run	Run	Auto
AL47	High SH driver 2	Run	Run	Auto
AL48	Sensor 1 driver 1	Off	Run	Auto
AL49	Sensor 1 driver 2	Run	Off	Auto
AL50	Sensor 2 driver 1	Off	Run	Auto
AL51	Sensor 2 driver 2	Run	Off	Auto
AL52	Sensor 3 driver 1	Off	Run	Auto
AL53	Sensor 3 driver 2	Run	Off	Auto
AL54	GoAhead driver 1	Run	Run	Auto
AL55	GoAhead driver 2	Run	Off	Auto
AL56	Lon driver 1 disconnected	Off	Run	Auto
AL57	Lon driver 2 disconnected	Run	Off	Auto
AL59	Auto set up driver 1	Off	Run	Auto
AL59	Auto set up driver 2	Run	Off	Auto
AL60	High limit discharge temp Sys 1	Off	On	Auto
AL61	High limit discharge temp Sys 2	On	Off	Auto
AL62	High limit discharge temp Sys 1	Off	On	Man
AL63	High limit discharge temp Sys 2	On	Off	Man
AL64	Alarm antifreeze recovery	Off recovery		Man

■ Setpoint

Pressing the Set key allows you to enter the Set point level accessible to the user. The parameters that can be set are listed below, along with the limit values and the default values (standard shop settings):

User parameters	Control mode	Min value	Max value	Default
Cooling Setpoint	RWT Return Control	8	20	10
	LWT Leaving Control	6	20	8
Cooling Setpoint - glycol water	RWT Return Control	-15	20	10
	LWT Leaving Control	-15	20	8
Proportional band Neutral band	RWT Return Control	1	10	5
	LWT Leaving Control	1	6	2
Heating Setpoint	RWT Return Control	20	45	40
	LWT Leaving Control	20	50	40
Languages	—	ITA ENG FRE GER SPA		ITA
System On/Off				
System 1 #	—	OFF	ON	OFF
System 2 #	—	OFF	ON	OFF
Unit Management		Cooling	Heating	

Control

6.4 Protection and Safety Equipment

Defrosting System (only for AQVH models)

The AQVH units are provided with an automatic defrosting system, which prevents the formation of excessive ice banks on coolant/air exchangers during heat pump operation.

This system, which is part of the electronic control system, is of the time/suction pressure type, and when the suction pressure detected by a sensor drops below a fixed limit, once the preset time is over, switches from heating to cooling the operation of the unit, with the fans stopped.

During the defrosting cycle the compressor works normally, but the coil's fans remain off. The defrosting cycle stops after the coil has been defrosted, and at this point the unit can work in heating mode again.



Both circuits are defrosted at the same time. For safety purposes, fans are started also during defrosting, if the discharge pressure reaches considerable values.

Frost Protection for the Chilled Fluid

These units are provided with frost protection for the chilled fluid. This protection consists of an electrical resistor positioned in contact with the coolant/circulating fluid exchanger, which is activated (although the unit is off) when the temperature of the fluid drops below 5 °C - the standard value for a non-glycol unit.

If the leaving water temperature drops below 4 °C (standard value for a non-glycol unit) the machine's antifreeze alarm is activated. If the circulating fluid is water, before the beginning of the cold season it is advisable to drain the circuit to prevent water frosting.

If the circuit cannot be drained, it is essential to avoid de-energizing the unit, so as to permit the activation, when necessary, of the frost protection.

Compressor protection

Compressors are equipped with a heating element to prevent oil dilution, which may result in remarkable risks of failure of compressors.

The windings of the compressors' motors are provided with a thermal protection.

For AQVL and AQVH models an accessory kit for

thermal protection is available, for any overcurrent of scroll compressors, which shall be shop-mounted.

Electrical flow switch

To ensure the correct operation of the unit, a electrical flow switch must be installed, to prevent the unit working in case of insufficient circulation of the chilled fluid.



The electrical flow switch must be carefully installed, according to the instructions given by the Manufacturer.

The electrical flow switch must be installed on the pressing side of the circulation pump for the fluid, just upstream of the heat exchanger's inlet. The electrical flow switch must be installed in a horizontal straight length of piping, in a position reasonably far (both upstream and downstream) from localized pressure drops (curves, valves etc.).

Continuous Regulation of the Fan Speed

The fans' speed regulator, if installed, allows the unit to work at an ambient temperature down to -18 °C.

Differential pressure switch

This pressure switch halts the operation of the unit in the event that it does not detect a sufficient pressure drop through the exchanger.

7 PRODUCT DESCRIPTION

7.1 General Information

AQVL/AQVH units are one-block type with two refrigerant circuits. They are intended to cool down the water required for any air-conditioning application as well as any other fluid, such as for example glycol water. These units are completely assembled at works. They are equipped with all the refrigerating connections and the internal electrical wiring required for a rapid installation on the field. An operation test is performed after assembly, with water flowing through the refrigerant/water exchanger in order to make sure that every refrigerating circuit is properly working. The refrigerating circuits of every unit are pressure tested before inspection, drained and charged with R410A. A low noise level is the result of a careful study. It is achieved on chillers by using technologically advanced components without negatively affecting the operation performances and limits of the units.

7.2 Body and Frame

The base and frame of these units are made with galvanized steel elements, assembled with stainless steel screws. All panels can be removed to ensure easy access to internal components. All galvanized steel parts are protected by epoxy powder paint.

7.3 Compressors

The models are equipped with four SCROLL airtight tandem compressors with an internal motor protection. The compressors of all models are assembled on rubber shock absorbers. Their motors can be directly started. They are cooled down by the aspirated refrigerant gas and equipped with internal thermostat protections against overloads. Overload protections are automatically reset after having tripped. The compressor terminal box has an IP21 protection degree. Compressors are powered on and off by the microprocessor of the unit control system which is intended to control the delivery of the thermal refrigerating capacity.

7.4 Evaporators

Evaporators are made of stainless steel plates. They are thermally insulated by means of a thick flexible insulating mattress with closed cells. The maximum operating pressures correspond to 10 bar for the water side and to 45 bar for the refrigerant side. Antifreeze protection for the water in the exchangers is ensured by electrical heaters and differential pressure switches.

7.5 Condensing coils

Condensers are coils made of copper tubes arranged in staggered rows and mechanically expanded inside an aluminium finned pack. The maximum operating pressure on the refrigerant side of the condensing batteries is 45 bar.

7.6 Condenser Fans

The condenser fans are of a helical type. They are directly coupled and have an impeller with wing contoured aluminium blades. Each fan is equipped with a galvanised steel accident-prevention protection which is painted after manufacture. The fans motors are completely closed. They have an IP54 protection degree and a protection thermostat embedded in the windings.

7.7 Fans Control

All models have a step speed controller as a standard. It will act according to the condensing pressure and allow the operation down to an Air temperature operation of +10°C.

7.8 Refrigerating Circuits

Each unit has a double refrigerating circuits equipped with external service valves intended to measure the refrigerant pressure and charge, sight glass with a humidity indicator, dryer filter and thermal expansion valve. Refrigerating circuits are also complete with high pressure switch as well as high and low transducer.

7.9 Control Supply Panel

All components of the control system and those necessary to start the motors are shop connected and tested. The control compartment contains an electronic card and a control board with an external keyboard and display, to show the operational functions, as well as the intervention of the alarms and the working blocks.

AQVL refrigeration diagram

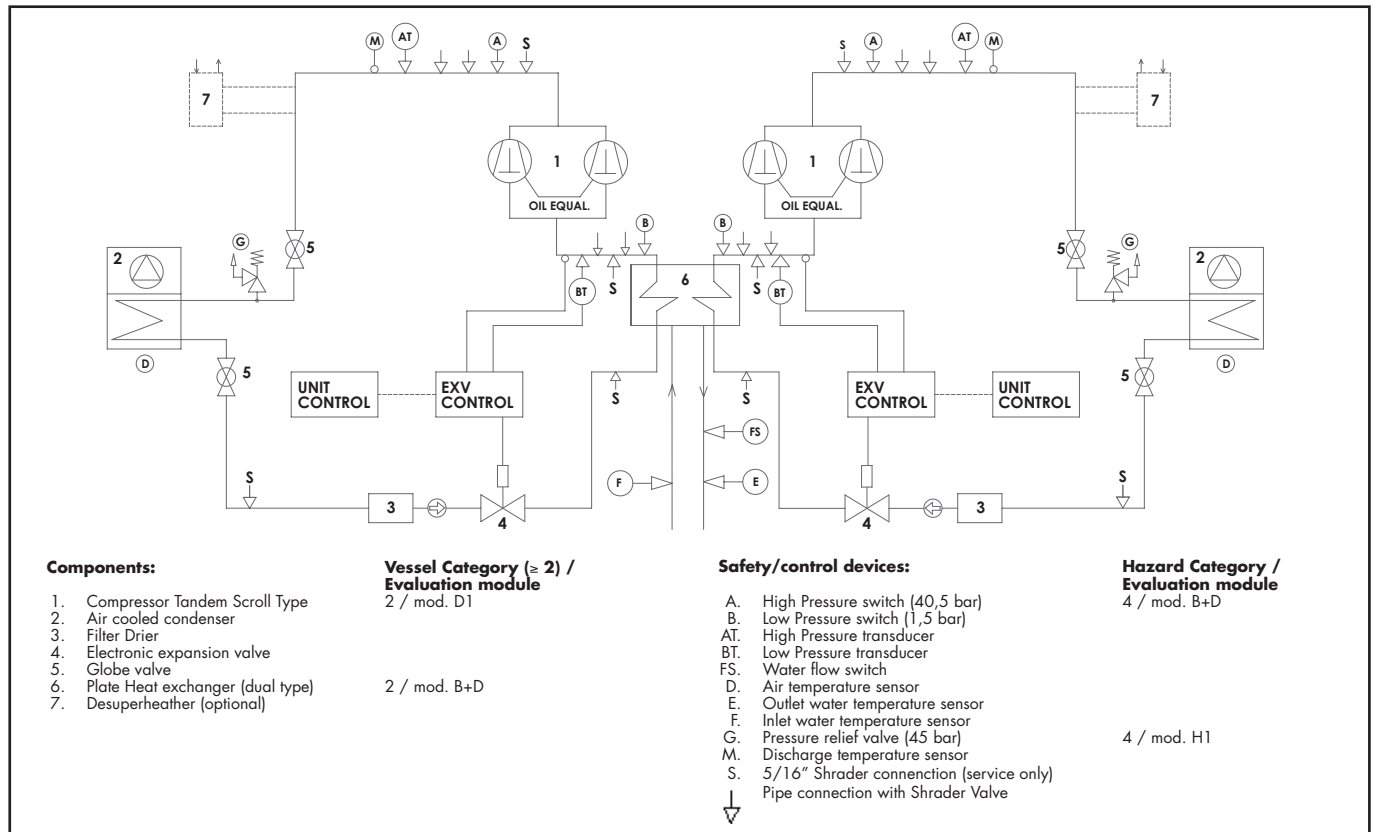

AQVH refrigeration diagram

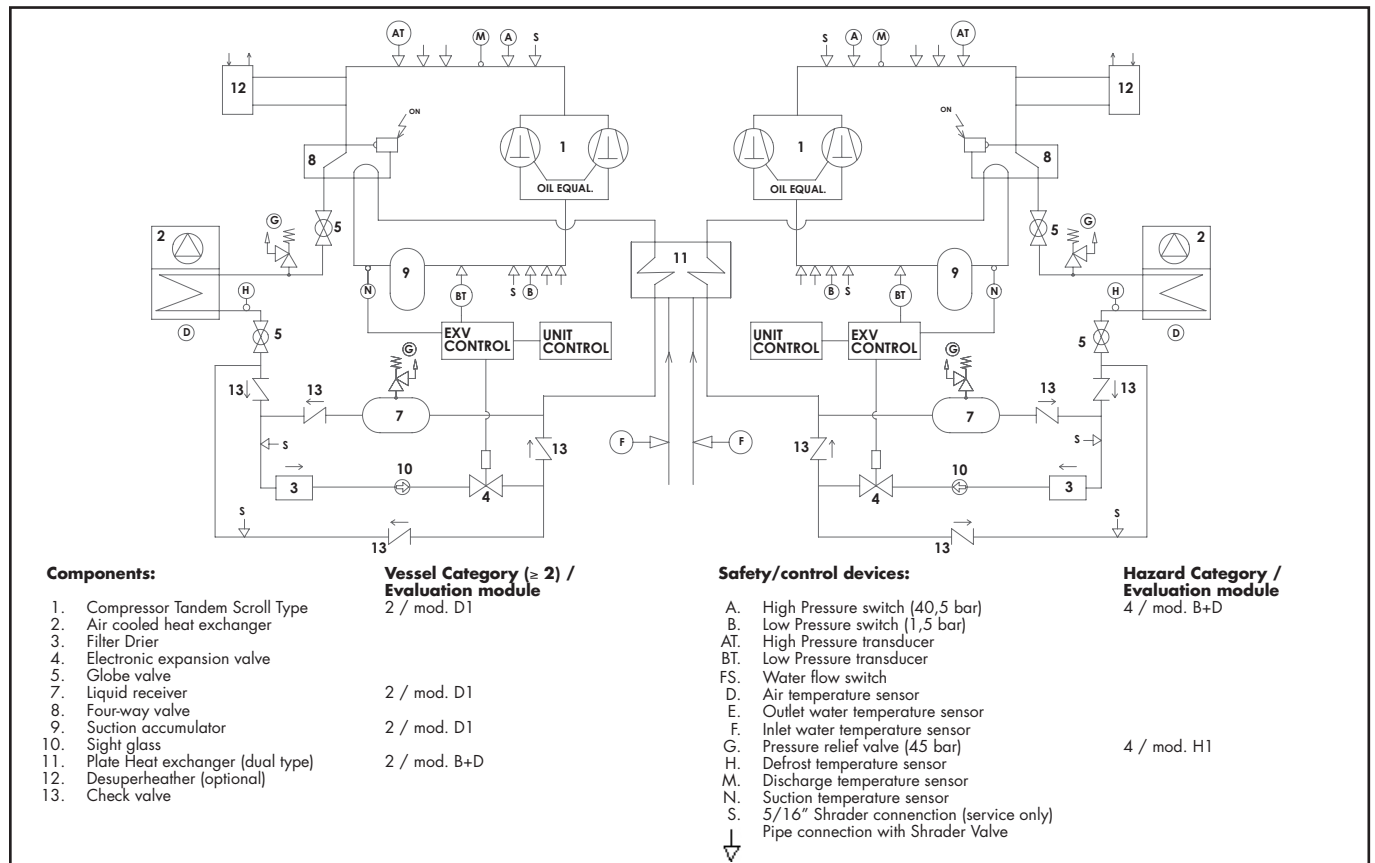

General Description

AQVC refrigeration diagram

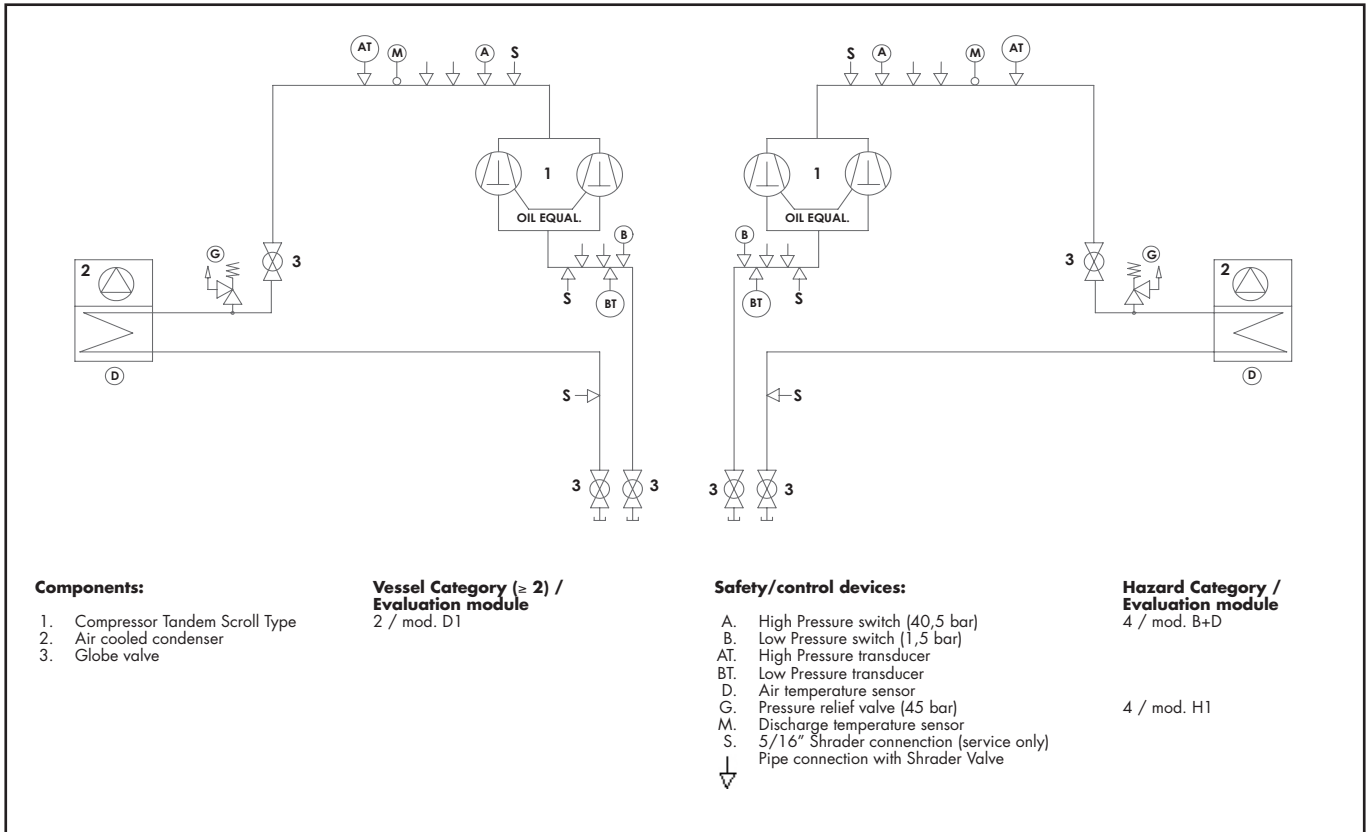

Components:

- 1. Compressor Tandem Scroll Type
- 2. Air cooled condenser
- 3. Globe valve

Vessel Category (≥ 2) / Evaluation module

2 / mod. D1

Safety/control devices:

- A. High Pressure switch (40,5 bar)
- B. Low Pressure switch (1,5 bar)
- AT. High Pressure transducer
- BT. Low Pressure transducer
- D. Air temperature sensor
- G. Pressure relief valve (45 bar)
- M. Discharge temperature sensor
- S. 5/16" Shrader connection (service only)
- ↓
Pipe connection with Shrader Valve

Hazard Category / Evaluation module

4 / mod. B+D

4 / mod. H1

8 TECHNICAL DATA

8.1 Pressure drops

PRESSURE DROP IN THE EVAPORATOR*							
AQVL		85	95	105	115	125	140
K	kPa/(l/s) ²	1,49	1,49	1,15	1,15	0,76	0,76
Minimum flow rate	l/s	2,50	2,80	3,07	3,30	3,65	4,10
Nominal flow rate	l/s	3,99	4,48	4,91	5,28	5,84	6,55
Maximum flow rate	l/s	6,66	7,46	8,19	8,81	9,74	10,92
Minimum pressure drop	kPa	9,3	11,7	10,8	12,5	10,1	12,7
Nominal pressure drop	kPa	23,8	29,9	27,7	32,1	25,9	32,5
Maximum pressure drop	kPa	66,1	83,0	76,9	89,1	71,8	90,3

$$\Delta P = K \cdot Q^2$$

PRESSURE DROP IN THE EVAPORATOR*							
AQVH		85	95	105	115	125	140
K	kPa/(l/s) ²	1,15	1,15	0,76	0,76	0,68	0,68
Minimum flow rate	l/s	2,42	2,69	2,96	3,20	3,47	3,87
Nominal flow rate	l/s	3,88	4,31	4,74	5,12	5,55	6,19
Maximum flow rate	l/s	6,47	7,18	7,90	8,53	9,25	10,32
Minimum pressure drop	kPa	6,8	8,3	6,6	7,8	8,1	10,1
Nominal pressure drop	kPa	17,3	21,3	17,0	19,9	20,8	25,9
Maximum pressure drop	kPa	48,0	59,2	47,3	55,2	57,8	71,9

$$\Delta P = K \cdot Q^2$$

PRESSURE DROP IN THE DESUPERHEATER*							
AQVL/H		85	95	105	115	125	140
K	kPa/(l/s) ²	78,74	78,74	58,61	58,61	42,48	42,48
Minimum flow rate	l/s	0,32	0,36	0,40	0,43	0,48	0,54
Nominal flow rate	l/s	0,52	0,58	0,64	0,69	0,76	0,86
Maximum flow rate	l/s	0,86	0,97	1,07	1,15	1,27	1,43
Minimum pressure drop	kPa	8,2	10,5	9,4	10,9	9,6	12,2
Nominal pressure drop	kPa	21,0	26,8	24,0	27,9	24,7	31,2
Maximum pressure drop	kPa	58,4	74,5	66,6	77,6	68,5	86,6

$$\Delta P = K \cdot Q^2$$

* data refer to BLN version

8.2 Technical data

AQVL BLN		85	95	105	115	125	140
Power supply	V/ph/Hz	400V/3/50Hz					
Number of refrigerant circuits		2	2	2	2	2	2
Total capacity steps	%	0-25-50-75-100	0-25-50-75-100	0-24-47-74-100	0-25-50-75-100	0-22-43-72-100	0-25-50-75-100
Refrigerant							
Type		R410A					
Charge	kg	17,6	19,7	21,6	23,2	25,7	28,8
Compressor							
Type		Scroll					
Number		4	4	4	4	4	4
Start-up type		Direct					
Oil type		POE					
N° of loading stages		0/100	0/100	0/100	0/100	0/100	0/100
Evaporator							
Type		Plate					
Number		1	1	1	1	1	1
Water flow rate	l/s	4,0	4,5	4,9	5,3	5,8	6,6
Pressure drop	kPa	Refers to Hydraulic features					
Desuperheater							
Type		Plate					
Number		2	2	2	2	2	2
Water flow rate	l/s	1,03	1,17	1,28	1,38	1,52	1,71
Pressure drop	kPa	Refers to Hydraulic features					
Fans							
Type		Axial					
Number		2	2	2	2	2	2
Nominal speed	rpm	690	690	690	690	900	900
Air flow rate	m ³ /s	9	9	9	9	12	12
Power input	kW	2,10	2,10	2,10	2,10	3,40	3,40
Air cooled condenser							
Type		Coil					
Number		2	2	2	2	2	2
Total coil face area per coil	m ²	2,4	2,4	2,4	2,4	3,1	3,1
Hydraulic connections (Evaporator)							
Type		Male Gas Threaded					
Inlet diameter	inch	2"1/2	2"1/2	2"1/2	2"1/2	2"1/2	2"1/2
Outlet diameter	inch	2"1/2	2"1/2	2"1/2	2"1/2	2"1/2	2"1/2
Hydraulic connections (Desuperheater)							
Type		Male Gas Threaded					
Inlet diameter	inch	1"	1"	1"	1"	1"	1"
Outlet diameter	inch	1"	1"	1"	1"	1"	1"
Weight							
Shipping weight	kg	1033	1047	1084	1116	1151	1230
Operating weight	kg	1058	1072	1111	1143	1183	1262
Dimensions							
Length	mm	2555	2555	2555	2555	3155	3155
Width	mm	1095 (1250)	1095 (1250)	1095 (1250)	1095 (1250)	1095 (1250)	1095 (1250)
Height	mm	2185	2185	2185	2185	2185	2185

AQVL ELN		85	95	105	115	125	140
Power supply	V/ph/Hz	400V/3/50Hz					
Number of refrigerant circuits		2	2	2	2	2	2
Total capacity steps	%	0-25-50-75-100	0-25-50-75-100	0-24-47-74-100	0-25-50-75-100	0-22-43-72-100	0-25-50-75-100

Refrigerant

Type		R410A					
Charge (l)	kg	17,0	19,0	20,7	22,2	25,1	28,1

Compressor

Type		Scroll					
Number		4	4	4	4	4	4
Start-up type		Direct					
Oil type		POE					
N° of loading stages		0/100	0/100	0/100	0/100	0/100	0/100

Evaporator

Type		Plate					
Number		1	1	1	1	1	1
Water flow rate	l/s	3,9	4,3	4,7	5,1	5,7	6,4
Pressure drop	kPa	Refers to Hydraulic features					

Desuperheater

Type		Plate					
Number		2	2	2	2	2	2
Water flow rate	l/s	1,02	1,15	1,26	1,36	1,51	1,70
Pressure drop	kPa	Refers to Hydraulic features					

Fans

Type		Axial					
Number		2	2	2	2	2	2
Nominal speed	rpm	500	500	500	500	690	690
Air flow rate	m³/s	7,00	7,00	6,83	6,7	10,1	9,7
Power input	kW	1,8	1,8	1,8	1,8	2,1	2,1

Air cooled condenser

Type		Coil					
Number		2	2	2	2	2	2
Total coil face area per coil	m²	2,4	2,4	2,4	2,4	3,1	3,1

Hydraulic connections (Evaporator)

Type		Male Gas Threaded					
Inlet diameter	inch	2"1/2	2"1/2	2"1/2	2"1/2	2"1/2	2"1/2
Outlet diameter	inch	2"1/2	2"1/2	2"1/2	2"1/2	2"1/2	2"1/2

Hydraulic connections (Desuperheater)

Type		Male Gas Threaded					
Inlet diameter	inch	1"	1"	1"	1"	1"	1"
Outlet diameter	inch	1"	1"	1"	1"	1"	1"

Weight

Shipping weight	kg	1063	1077	1114	1146	1181	1260
Operating weight	kg	1088	1102	1141	1173	1213	1292

Dimensions

Length	mm	2555	2555	2555	2555	3155	3155
Width	mm	1095 (1250)	1095 (1250)	1095 (1250)	1095 (1250)	1095 (1250)	1095 (1250)
Height	mm	2185	2185	2185	2185	2185	2185

Technical data

AQVL HT		85	95	105	115	125	140
Power supply	V/ph/Hz	400V/3/50Hz					
Number of refrigerant circuits		2	2	2	2	2	2
Total capacity steps	%	0-25-50-75-100	0-25-50-75-100	0-24-47-74-100	0-25-50-75-100	0-22-43-72-100	0-25-50-75-100

Refrigerant

Type		R410A					
Charge (l)	kg	18,1	20,4	22,4	24,2	26,2	29,3

Compressor

Type		Scroll					
Number		4	4	4	4	4	4
Start-up type		Direct					
Oil type		POE					
N° of loading stages		0/100	0/100	0/100	0/100	0/100	0/100

Evaporator

Type		Plate					
Number		1	1	1	1	1	1
Water flow rate	l/s	4,12	4,63	5,11	5,51	5,95	6,67
Pressure drop	kPa	Refers to Hydraulic features					

Desuperheater

Type		Plate					
Number		2	2	2	2	2	2
Water flow rate	l/s	1,05	1,18	1,30	1,40	1,53	1,72
Pressure drop	kPa	Refers to Hydraulic features					

Fans

Type		Axial					
Number		2	2	2	2	2	2
Nominal speed	rpm	1130	1130	1130	1130	1130	1130
Air flow rate	m ³ /s	13,81	13,81	13,6	13,4	14,5	14,1
Power input	kW	4,6	4,6	4,6	4,6	4,6	4,6

Air cooled condenser

Type		Coil					
Number		2	2	2	2	2	2
Total coil face area per coil	m ²	2,4	2,4	2,4	2,4	3,12	3,12

Hydraulic connections (Evaporator)

Type		Male Gas Threaded					
Inlet diameter	inch	2"1/2	2"1/2	2"1/2	2"1/2	2"1/2	2"1/2
Outlet diameter	inch	2"1/2	2"1/2	2"1/2	2"1/2	2"1/2	2"1/2

Hydraulic connections (Desuperheater)

Type		Male Gas Threaded					
Inlet diameter	inch	1"	1"	1"	1"	1"	1"
Outlet diameter	inch	1"	1"	1"	1"	1"	1"

Weight

Shipping weight	kg	1033	1047	1084	1116	1151	1230
Operating weight	kg	1058	1072	1111	1143	1183	1262

Dimensions

Length	mm	2555	2555	2555	2555	3155	3155
Width	mm	1095 (1250)	1095 (1250)	1095 (1250)	1095 (1250)	1095 (1250)	1095 (1250)
Height	mm	2185	2185	2185	2185	2185	2185

AQVH BLN		85	95	105	115	125	140
Power supply	V/ph/Hz	400V/3/50Hz					
Number of refrigerant circuits		2	2	2	2	2	2
Total capacity steps	%	0-25-50-75-100	0-25-50-75-100	0-24-47-74-100	0-25-50-75-100	0-22-43-72-100	0-25-50-75-100

Refrigerant

Type		R410A					
Charge (l)	kg	21,1	23,4	25,8	27,9	30,2	33,7

Compressor

Type		Scroll					
Number		4	4	4	4	4	4
Start-up type		Direct					
Oil type		POE					
N° of loading stages		0/100	0/100	0/100	0/100	0/100	0/100

Evaporator

Type		Plate					
Number		1	1	1	1	1	1
Water flow rate	l/s	3,9	4,3	4,7	5,1	5,6	6,2
Pressure drop	kPa	Refers to Hydraulic features					

Desuperheater

Type		Plate					
Number		2	2	2	2	2	2
Water flow rate	l/s	1,02	1,14	1,25	1,35	1,47	1,65
Pressure drop	kPa	Refers to Hydraulic features					

Fans

Type		Axial					
Number		2	2	2	2	2	2
Nominal speed	rpm	690	690	690	690	900	900
Air flow rate	m ³ /s	9,6	9,6	9,5	9,3	12,4	12,0
Power input	kW	2,1	2,1	2,1	2,1	3,4	3,4

Air cooled condenser

Type		Coil					
Number		2	2	2	2	2	2
Total coil face area per coil	m ²	2,4	2,4	2,4	2,4	3,1	3,1

Hydraulic connections (Evaporator)

Type		Male Gas Threaded					
Inlet diameter	inch	2"1/2	2"1/2	2"1/2	2"1/2	2"1/2	2"1/2
Outlet diameter	inch	2"1/2	2"1/2	2"1/2	2"1/2	2"1/2	2"1/2

Hydraulic connections (Desuperheater)

Type		Male Gas Threaded					
Inlet diameter	inch	1"	1"	1"	1"	1"	1"
Outlet diameter	inch	1"	1"	1"	1"	1"	1"

Weight

Shipping weight	kg	1065	1080	1122	1153	1196	1270
Operating weight	kg	1090	1105	1149	1180	1227	1301

Dimensions

Length	mm	2555	2555	2555	2555	3155	3155
Width	mm	1095 (1250)	1095 (1250)	1095 (1250)	1095 (1250)	1095 (1250)	1095 (1250)
Height	mm	2185	2185	2185	2185	2185	2185

Technical data

AQVH ELN		85	95	105	115	125	140
Power supply	V/ph/Hz	400V/3/50Hz					
Number of refrigerant circuits		2	2	2	2	2	2
Total capacity steps	%	0-25-50-75-100	0-25-50-75-100	0-24-47-74-100	0-25-50-75-100	0-22-43-72-100	0-25-50-75-100

Refrigerant

Type		R410A					
Charge (l)	kg	20,4	22,6	24,7	26,7	29,2	32,5

Compressor

Type		Scroll					
Number		4	4	4	4	4	4
Start-up type		Direct					
Oil type		POE					
N° of loading stages		0/100	0/100	0/100	0/100	0/100	0/100

Evaporator

Type		Plate					
Number		1	1	1	1	1	1
Water flow rate	l/s	3,7	4,1	4,5	4,9	5,4	6,0
Pressure drop	kPa	Refers to Hydraulic features					

Desuperheater

Type		Plate					
Number		2	2	2	2	2	2
Water flow rate	l/s	1,00	1,13	1,23	1,33	1,46	1,63
Pressure drop	kPa	Refers to Hydraulic features					

Fans

Type		Axial					
Number		2	2	2	2	2	2
Nominal speed	rpm	500	500	500	500	690	690
Air flow rate	m ³ /s	7,2	7,2	7	6,9	10,3	9,9
Power input	kW	1,8	1,8	1,8	1,8	2,1	2,1

Air cooled condenser

Type		Coil					
Number		2	2	2	2	2	2
Total coil face area per coil	m ²	2,4	2,4	2,4	2,4	3,1	3,1

Hydraulic connections (Evaporator)

Type		Male Gas Threaded					
Inlet diameter	inch	2"1/2	2"1/2	2"1/2	2"1/2	2"1/2	2"1/2
Outlet diameter	inch	2"1/2	2"1/2	2"1/2	2"1/2	2"1/2	2"1/2

Hydraulic connections (Desuperheater)

Type		Male Gas Threaded					
Inlet diameter	inch	1"	1"	1"	1"	1"	1"
Outlet diameter	inch	1"	1"	1"	1"	1"	1"

Weight

Shipping weight	kg	1095	1110	1152	1183	1226	1300
Operating weight	kg	1120	1135	1179	1210	1257	1331

Dimensions

Length	mm	2555	2555	2555	2555	3155	3155
Width	mm	1095 (1250)	1095 (1250)	1095 (1250)	1095 (1250)	1095 (1250)	1095 (1250)
Height	mm	2185	2185	2185	2185	2185	2185

AQVH HT		85	95	105	115	125	140
Power supply	V/ph/Hz	400V/3/50Hz					
Number of refrigerant circuits		2	2	2	2	2	2
Total capacity steps	%	0-25-50-75-100	0-25-50-75-100	0-24-47-74-100	0-25-50-75-100	0-22-43-72-100	0-25-50-75-100

Refrigerant

Type		R410A					
Charge (l)	kg	22	24	27	29	31	34

Compressor

Type		Scroll					
Number		4	4	4	4	4	4
Start-up type		Direct					
Oil type		POE					
N° of loading stages		0/100	0/100	0/100	0/100	0/100	0/100

Evaporator

Type		Plate					
Number		1	1	1	1	1	1
Water flow rate	l/s	4,0	4,5	5,0	5,3	5,6	6,3
Pressure drop	kPa	Refers to Hydraulic features					

Desuperheater

Type		Plate					
Number		2	2	2	2	2	2
Water flow rate	l/s	1,02	1,15	1,27	1,37	1,48	1,66
Pressure drop	kPa	Refers to Hydraulic features					

Fans

Type		Axial					
Number		2	2	2	2	2	2
Nominal speed	rpm	1130	1130	1130	1130	1130	1130
Air flow rate	m³/s	14,08	14,08	13,81	13,53	14,64	14,36
Power input	kW	4,6	4,6	4,6	4,6	4,6	4,6

Air cooled condenser

Type		Coil					
Number		2	2	2	2	2	2
Total coil face area per coil	m²	2,4	2,4	2,4	2,4	3,1	3,1

Hydraulic connections (Evaporator)

Type		Male Gas Threaded					
Inlet diameter	inch	2"1/2	2"1/2	2"1/2	2"1/2	2"1/2	2"1/2
Outlet diameter	inch	2"1/2	2"1/2	2"1/2	2"1/2	2"1/2	2"1/2

Hydraulic connections (Desuperheater)

Type		Male Gas Threaded					
Inlet diameter	inch	1"	1"	1"	1"	1"	1"
Outlet diameter	inch	1"	1"	1"	1"	1"	1"

Weight

Shipping weight	kg	1065	1080	1122	1153	1196	1270
Operating weight	kg	1090	1105	1149	1180	1227	1301

Dimensions

Length	mm	2555	2555	2555	2555	3155	3155
Width	mm	1095 (1250)	1095 (1250)	1095 (1250)	1095 (1250)	1095 (1250)	1095 (1250)
Height	mm	2185	2185	2185	2185	2185	2185

Technical data

AQVC BLN-HT		85	95	105	115	125	140
Power supply	V/ph/Hz	400V/3/50Hz					
Number of circuits		2	2	2	2	2	2
Capacity steps	%	0-25-50-75-100	0-25-50-75-100	0-24-47-74-100	0-25-50-75-100	0-22-43-72-100	0-25-50-75-100
Refrigerant							
Type		R410A					
Compressor							
Type		Scroll					
Number		4	4	4	4	4	4
Start-up type		Direct					
N° of loading stages		0/100	0/100	0/100	0/100	0/100	0/100
Condenser							
Type		Coil					
Refrigerant connections							
Inlet diameter	inch	5/8"	5/8"	5/8"	5/8"	7/8"	7/8"
Outlet diameter	inch	1"3/8	1"3/8	1"3/8	1"3/8	1"3/8	1"3/8
Weights							
Shipping weight	kg	1030	1042	1086	1102	1145	1220
Dimensions							
Length	mm	2555	2555	2555	2555	3155	3155
Width	mm	1095	1095	1095	1095	1095	1095
Height	mm	2185	2185	2185	2185	2185	2185

AQVC ELN		85	95	105	115	125	140
Power supply	V/ph/Hz	400V/3/50Hz					
Number of circuits		2	2	2	2	2	2
Capacity steps	%	0-25-50-75-100	0-25-50-75-100	0-24-47-74-100	0-25-50-75-100	0-22-43-72-100	0-25-50-75-100
Refrigerant							
Type		R410A					
Compressor							
Type		Scroll					
Number		4	4	4	4	4	4
Start-up type		Direct					
N° of loading stages		0/100	0/100	0/100	0/100	0/100	0/100
Condenser							
Type		Coil					
Refrigerant connections							
Inlet diameter	inch	5/8"	5/8"	5/8"	5/8"	7/8"	7/8"
Outlet diameter	inch	1"3/8	1"3/8	1"3/8	1"3/8	1"3/8	1"3/8
Weights							
Shipping weight	kg	1060	1072	1116	1132	1175	1250
Dimensions							
Length	mm	2555	2555	2555	2555	3155	3155
Width	mm	1095	1095	1095	1095	1095	1095
Height	mm	2185	2185	2185	2185	2185	2185

8.3 Unit electrical data

AQVL/AQVH BLN		85	95	105	115	125	140
Rated voltage	V/ph/Hz	400V/3/50Hz					
Max. absorbed power	kW	39	43	47	50	57	63
Rated Current		50	55	60	66	77	84
Max. current FLA	A	68	88	90	92	114	132
Max. start-up current LRA	A	147	178	186	188	223	241
External fuses	A	100	100	125	125	125	160
Max. cable section (*)	mm ²	50	50	50	50	70	70

Exchanger resistance

Rated voltage	V/ph/Hz	230/ (± 10%)/1/50					
Max. absorbed power	W	130					

AQVL/AQVH ELN		85	95	105	115	125	140
Rated voltage	V/ph/Hz	400V/3/50Hz					
Max. absorbed power	kW	39	43	47	50	56	61
Rated Current		50	55	60	66	73	81
Max. current FLA	A	68	88	90	92	110	128
Max. start-up current LRA	A	147	178	186	188	219	237
External fuses	A	100	100	125	125	125	160
Max. cable section (*)	mm ²	50	50	50	50	70	70

Exchanger resistance

Rated voltage	V/ph/Hz	230/ (± 10%)/1/50					
Max. absorbed power	W	130					

AQVL/AQVH HT/HSE/HPF		85	95	105	115	125	140
Rated voltage	V/ph/Hz	400V/3/50Hz					
Max. absorbed power	kW	42	46	50	53	59	65
Rated Current		54	60	65	70	78	85
Max. current FLA	A	73	93	95	97	115	133
Max. start-up current LRA	A	152	183	191	193	224	242
External fuses	A	100	100	125	125	125	160
Max. cable section (*)	mm ²	50	50	50	50	70	70

Exchanger resistance

Rated voltage	V/ph/Hz	230/ (± 10%)/1/50					
Max. absorbed power	W	130					

(*) The dimensioning of the unit's power cables is the responsibility of the installer, who shall consider: the rating, the maximum working temperature in the room, the type of insulation and the cable laying, the maximum length of the power supply line.

Technical data

Compressor electrical data

AQVL/AQVH BLN-ELN		85	95	105	115	125	140
Number		4	4	4	4	4	4
Max. absorbed power	kW	9,1+9,1+9,1+9,1	10,2+10,2+10,2+10,2	12+12+10,2+10,2	12+12+12+12	14,8+12+14,8+12	14,8+14,8+14,8+14,8
Rated current	A	95+95+95+95	111+111+111+111	118+118+111+111	118+118+118+118	140+118+140+118	140+140+140+140
Max current	A	16+16+16+16	21+21+21+21	22+22+21+21	22+22+22+22	31+22+31+22	31+31+31+31
Oil pan resistor	W	90+90+90+90	90+90+90+90	90+90+90+90	90+90+90+90	90+90+90+90	90+90+90+90

Fans electrical data

AQVL/AQVH BLN		85	95	105	115	125	140
Rated voltage	V/ph/Hz	400V/3/50Hz					
Number		2	2	2	2	2	2
Rated power	kW	1,2	1,2	1,2	1,2	1,95	1,95
Absorbed rated current FLA	A	2,2	2,2	2,2	2,2	3,9	3,9

AQVL/AQVH ELN		85	95	105	115	125	140
Rated voltage	V/ph/Hz	400V/3/50Hz					
Number		2	2	2	2	2	2
Rated power	kW	1,2	1,2	1,2	1,2	1,2	1,2
Absorbed rated current FLA	A	2,2	2,2	2,2	2,2	2,2	2,2

AQVL/AQVH HT/HPF/HSE		85	95	105	115	125	140
Rated voltage	V/ph/Hz	400V/3/50Hz					
Number		2	2	2	2	2	2
Rated power	kW	2,8	2,8	2,8	2,8	2,8	2,8
Absorbed rated current FLA	A	4,5	4,5	4,5	4,5	4,5	4,5

Pumps electrical data

AQVL/AQVH 1/2P		85	95	105	115	125	140
Nominal power	kW	1,99	1,99	1,99	2,47	2,47	2,47
Max. running current	A	3,65	3,65	3,65	4,98	4,98	4,98

AQVL/AQVH 3P		85	95	105	115	125	140
Nominal power	kW	1,43	1,43	1,43	1,84	1,84	1,84
Max. running current	A	2,70	2,70	2,70	3,49	3,49	3,49

8.4 Hydraulic Features

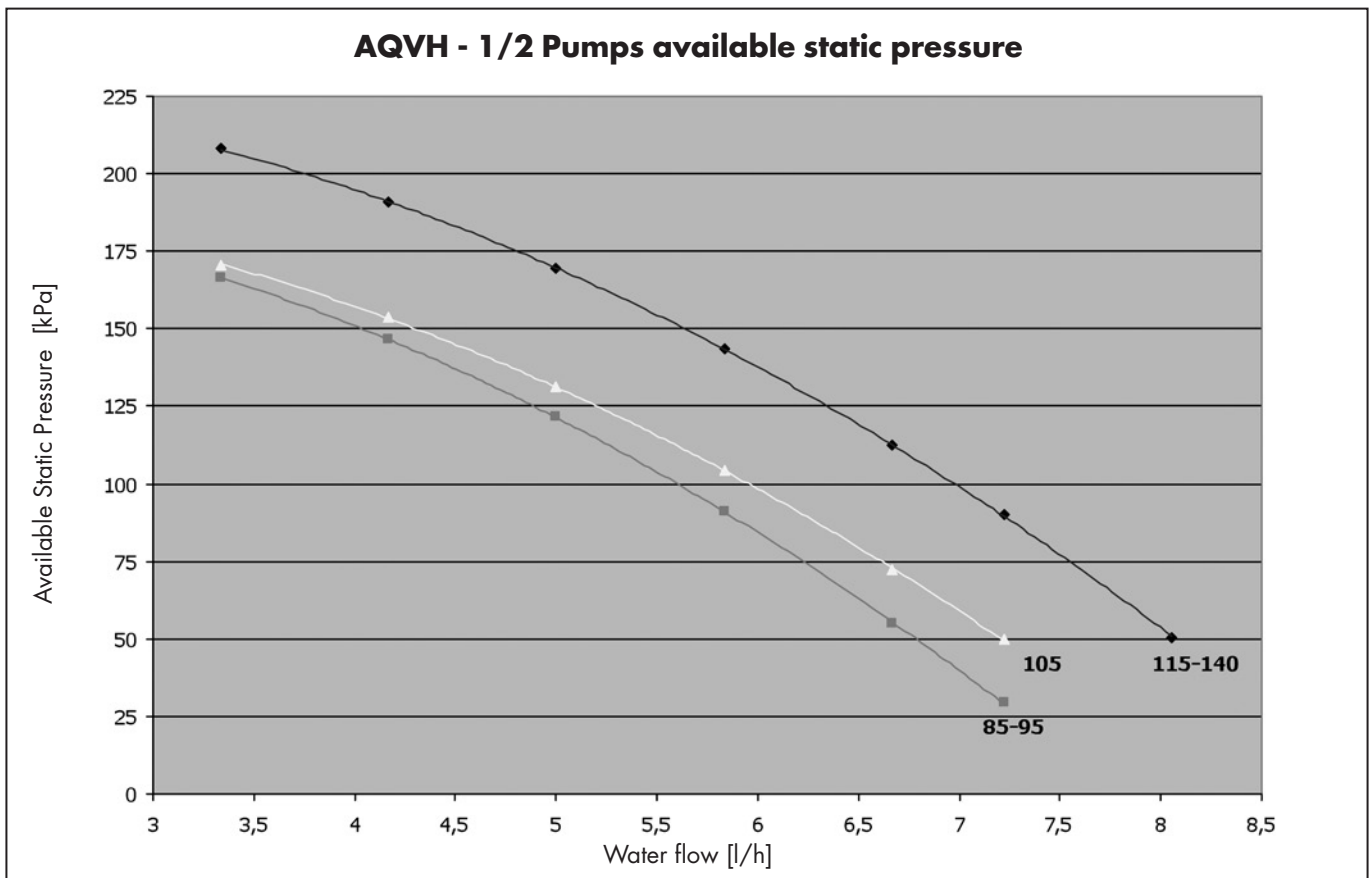
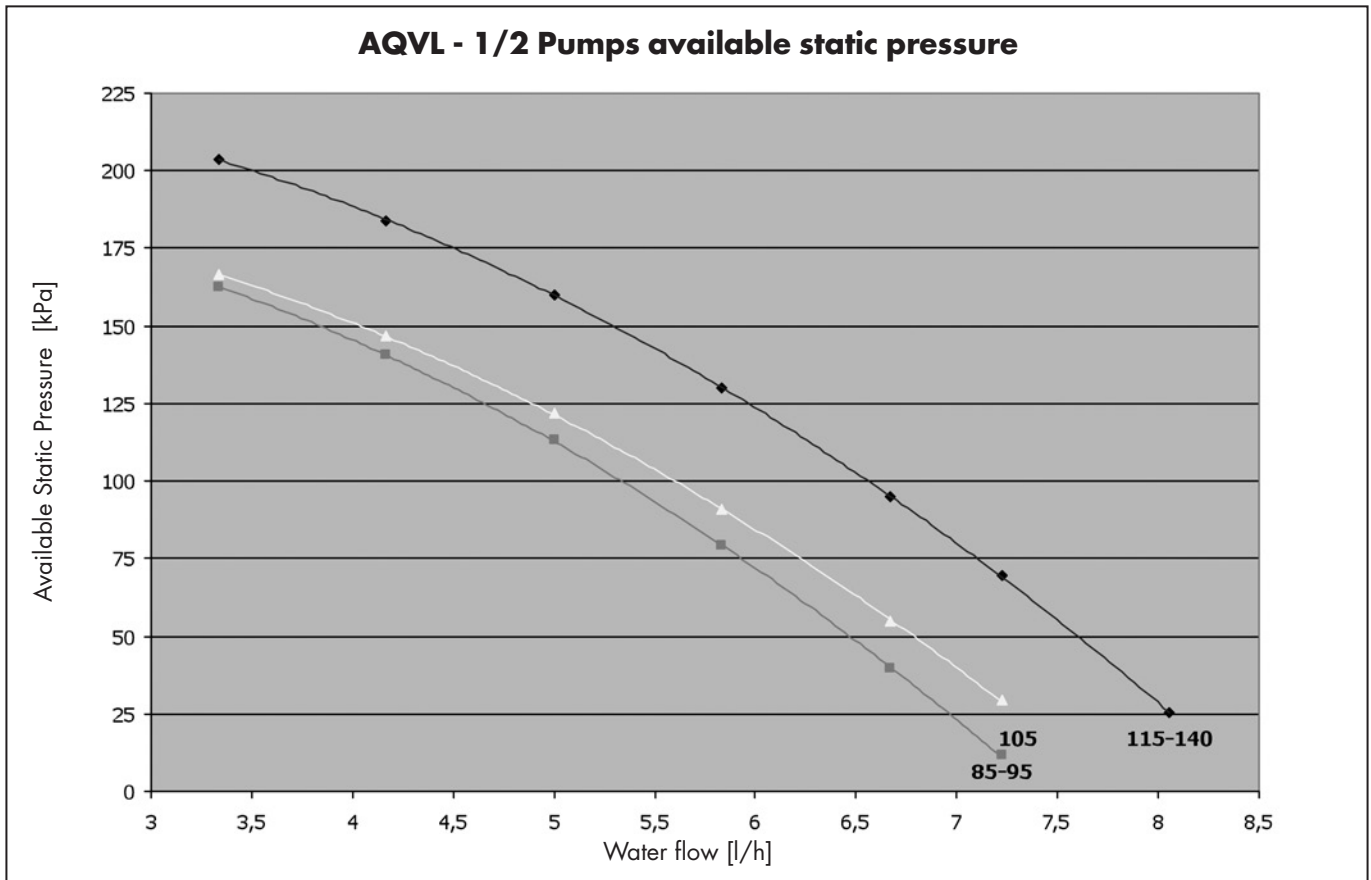

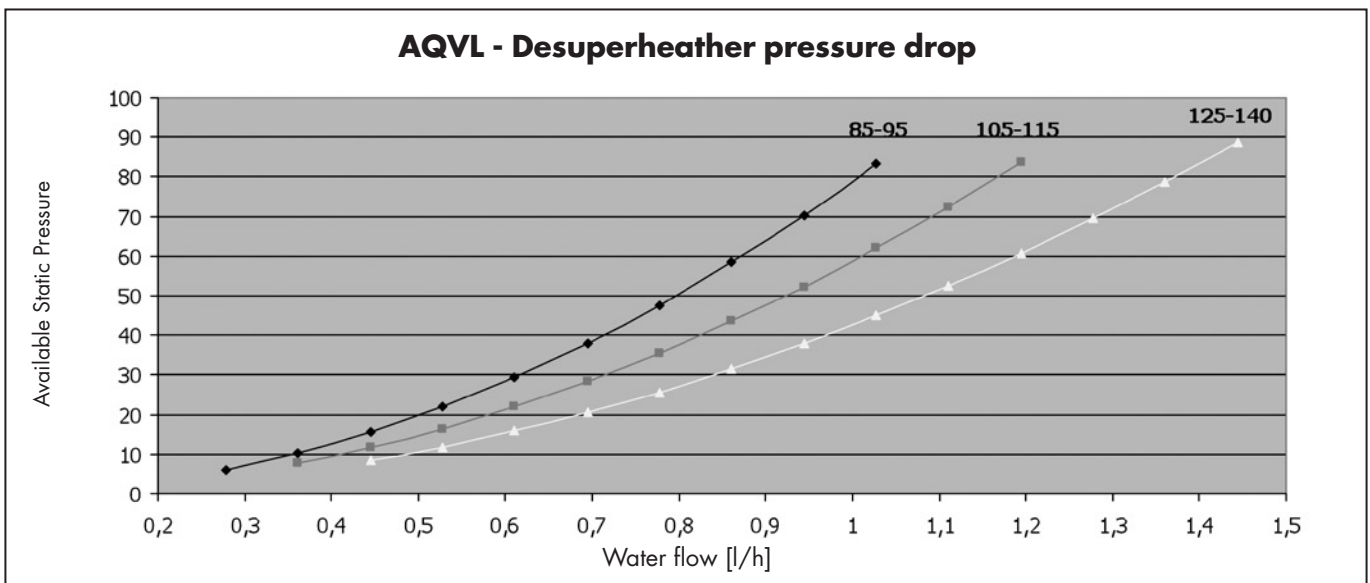
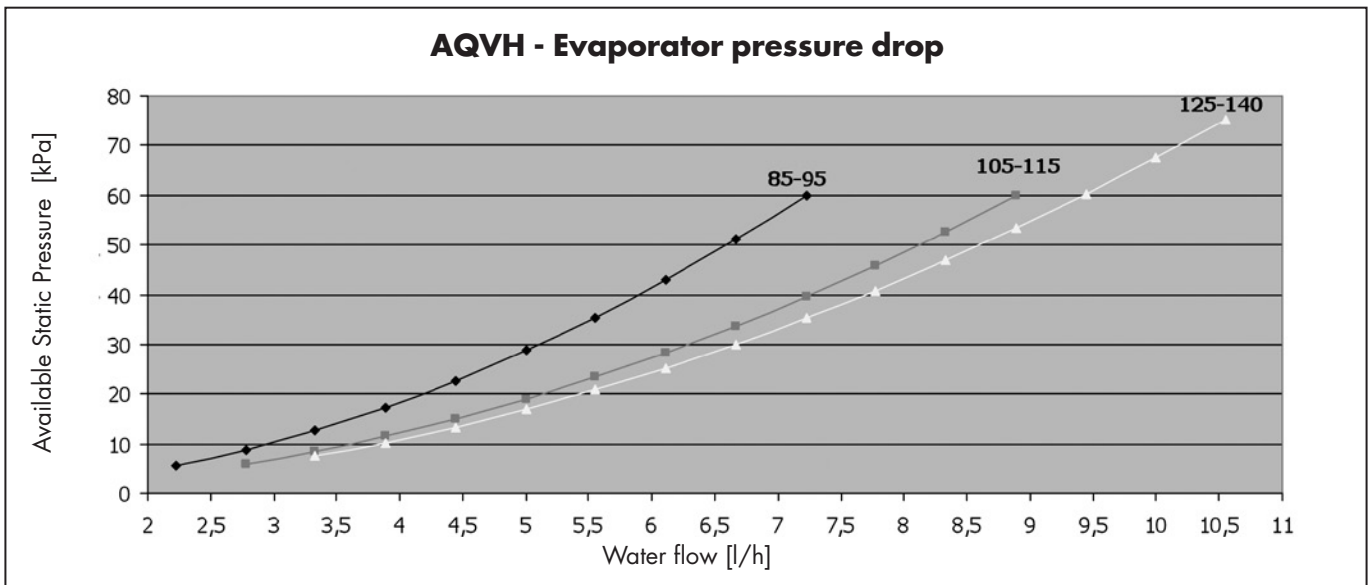
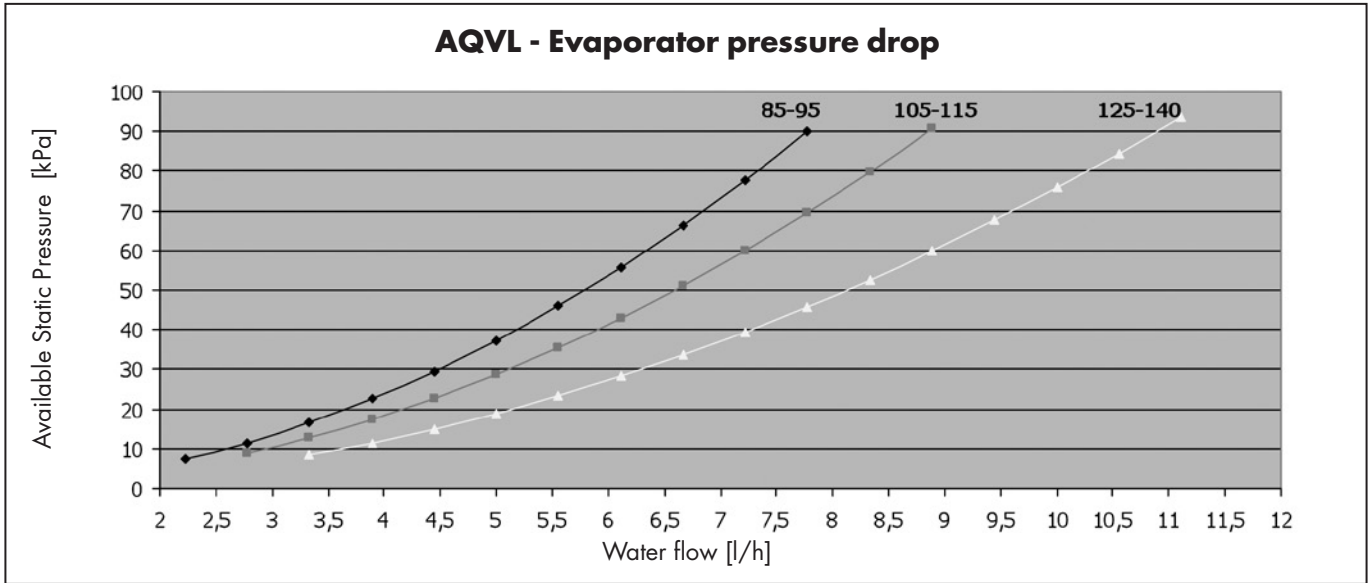

8.5 Position of shock adsorbers and weight distribution on supports

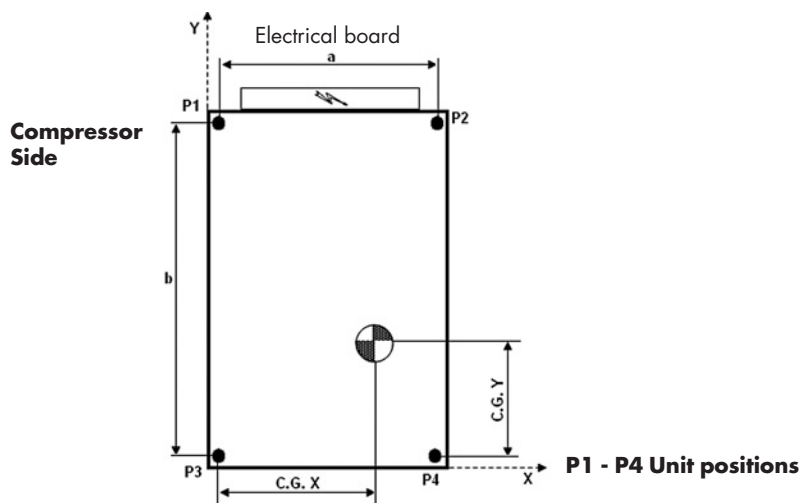

AQVL 85 - 140 Al/Cu Version BLN/ELN/HT

AQVL Al/Cu	Weight distribution				Operating weight kg	Shipping weight kg	P1-P4 coordinates*		CG coordinates	
	F1	F2	F3	F4			a	b	x	y
	kg	kg	kg	kg			mm	mm	mm	mm
85	417	408	121	111	1058	1033	1039	1382	538	1549
95	424	414	122	112	1072	1047	1039	1382	538	1552
105	432	429	127	124	1111	1084	1039	1382	545	1541
115	445	434	137	127	1143	1116	1039	1382	538	1533
125	425	415	176	166	1183	1151	1039	1982	539	1897
140	448	435	195	183	1262	1230	1039	1982	537	1877
85 1P	433	399	165	131	1128	1086	1039	1382	516	1485
95 1P	453	419	152	119	1143	1101	1039	1382	517	1523
105 1P	450	422	173	145	1190	1145	1039	1382	524	1478
115 1P	463	428	184	148	1222	1178	1039	1382	517	1472
125 1P	478	444	184	149	1255	1206	1039	1982	519	1945
140 1P	470	433	234	197	1334	1285	1039	1982	519	1831
85 2P	439	399	173	133	1145	1102	1039	1382	511	1478
95 2P	458	418	159	120	1155	1112	1039	1382	512	1517
105 2P	456	422	181	147	1206	1161	1039	1382	519	1471
115 2P	469	428	192	150	1239	1194	1039	1382	513	1465
125 2P	486	445	191	150	1272	1223	1039	1982	514	1939
140 2P	478	435	241	198	1352	1303	1039	1982	514	1826
85 3P	441	398	183	140	1162	1119	1039	1382	509	1462
95 3P	461	418	170	128	1177	1134	1039	1382	510	1499
105 3P	457	421	191	155	1223	1179	1039	1382	517	1456
115 3P	471	427	201	157	1256	1211	1039	1382	511	1451
125 3P	489	445	200	157	1292	1242	1039	1982	512	1923
140 3P	481	435	251	205	1371	1322	1039	1982	513	1813
85 1PT	429	404	269	243	1345	1138	1039	1382	528	1308
95 1PT	449	424	256	231	1360	1153	1039	1382	528	1342
105 1PT	446	427	276	258	1407	1197	1039	1382	534	1310
115 1PT	459	432	287	260	1439	1230	1039	1382	528	1308
125 1PT	489	471	344	327	1631	1274	1039	1982	536	1655
140 1PT	481	461	395	375	1710	1353	1039	1982	535	1580
85 2PT	436	404	278	246	1364	1156	1039	1382	523	1303
95 2PT	456	424	265	233	1379	1171	1039	1382	523	1336
105 2PT	453	427	286	260	1425	1216	1039	1382	529	1305
115 2PT	466	432	297	263	1458	1248	1039	1382	524	1303
125 2PT	497	472	353	328	1651	1294	1039	1982	532	1653
140 2PT	489	462	403	376	1731	1373	1039	1982	531	1578

* Dimensions are referred to unit with antivibration mounted isolators.

Technical data

AQVL 85 - 140 Cu/Cu Version BLN/ELN/HT

AQVL Cu/Cu	Weight distribution				Operating weight	Shipping weight	P1-P4 coordinates*		CG coordinates	
	F1	F2	F3	F4			a	b	x	y
	kg	kg	kg	kg			mm	mm	mm	mm
85	474	464	172	161	1270	1231	1039	1382	539	1486
95	481	470	172	162	1285	1260	1039	1382	539	1489
105	493	499	181	186	1359	1332	1039	1382	552	1474
115	521	509	204	193	1427	1400	1039	1382	539	1462
125	495	484	245	234	1458	1427	1039	1982	540	1819
140	541	527	288	274	1629	1598	1039	1982	539	1788
85 1P	490	455	215	181	1341	1299	1039	1382	521	1436
95 1P	532	497	181	146	1356	1313	1039	1382	521	1517
105 1P	511	492	227	208	1438	1393	1039	1382	534	1426
115 1P	539	502	251	214	1506	1461	1039	1382	522	1416
125 1P	548	512	253	217	1530	1481	1039	1982	524	1862
140 1P	563	525	326	288	1702	1653	1039	1982	524	1756
85 2P	496	455	223	183	1357	1315	1039	1382	516	1430
95 2P	537	496	188	147	1368	1325	1039	1382	517	1511
105 2P	517	492	235	210	1454	1409	1039	1382	530	1420
115 2P	545	502	259	216	1522	1477	1039	1382	519	1411
125 2P	555	513	260	219	1548	1499	1039	1982	519	1858
140 2P	570	526	334	289	1720	1670	1039	1982	521	1753
85 3P	498	454	233	190	1375	1332	1039	1382	515	1417
95 3P	539	496	199	155	1390	1347	1039	1382	515	1497
105 3P	519	491	245	217	1472	1427	1039	1382	528	1409
115 3P	546	501	269	223	1540	1495	1039	1382	517	1400
125 3P	559	514	270	225	1567	1518	1039	1982	518	1845
140 3P	574	526	343	295	1739	1699	1039	1982	519	1743
85 1PT	486	460	319	293	1558	1351	1039	1382	530	1290
95 1PT	528	502	285	258	1573	1365	1039	1382	530	1361
105 1PT	508	497	330	320	1655	1445	1039	1382	541	1290
115 1PT	535	507	354	326	1723	1513	1039	1382	531	1286
125 1PT	558	539	414	395	1906	1549	1039	1982	537	1630
140 1PT	573	552	487	465	2078	1721	1039	1982	537	1562
85 2PT	493	460	328	296	1577	1369	1039	1382	526	1285
95 2PT	535	502	294	261	1592	1384	1039	1382	526	1356
105 2PT	514	497	340	323	1674	1464	1039	1382	537	1285
115 2PT	542	507	364	329	1742	1532	1039	1382	527	1282
125 2PT	567	541	423	396	1926	1569	1039	1982	533	1628
140 2PT	582	553	496	467	2098	1741	1039	1982	533	1561

* Dimensions are referred to unit with antivibration mounted isolators.

AQVL 85 - 140 MCHX

AQVL MCHX	Weight distribution				Operating weight	Shipping weight	P1-P4 coordinates*		CG coordinates	
	F1	F2	F3	F4			a	b	x	y
	kg	kg	kg	kg			mm	mm	mm	mm
85	383	373	100	90	946	921	1039	1382	537	1593
95	481	470	172	162	1285	1260	1039	1382	539	1489
105	389	379	100	91	958	934	1039	1382	537	1596
115	392	383	102	92	969	942	1039	1382	538	1594
125	395	384	102	92	973	946	1039	1382	537	1595
140	388	378	139	130	1035	1004	1039	1982	538	1956
85 1P	397	363	147	114	1022	979	1039	1382	513	1517
95 1P	406	373	146	112	1037	994	1039	1382	514	1528
105 1P	410	376	153	119	1057	1012	1039	1382	514	1516
115 1P	413	378	154	119	1064	1019	1039	1382	514	1516
125 1P	443	409	149	115	1116	1067	1039	1982	516	2003
140 1P	418	382	182	146	1128	1079	1039	1982	514	1895
85 2P	403	363	156	116	1038	995	1039	1382	508	1509
95 2P	409	370	151	112	1041	999	1039	1382	508	1523
105 2P	415	376	161	121	1073	1029	1039	1382	509	1508
115 2P	418	378	162	122	1080	1035	1039	1382	508	1508
125 2P	451	411	156	116	1134	1085	1039	1982	511	1995
140 2P	426	383	189	147	1146	1096	1039	1982	509	1889
85 3P	404	361	166	124	1055	1013	1039	1382	506	1491
95 3P	413	371	164	122	1070	1028	1039	1382	507	1501
105 3P	416	374	172	129	1091	1046	1039	1382	507	1490
115 3P	419	376	173	129	1097	1053	1039	1382	506	1490
125 3P	454	411	166	122	1153	1104	1039	1982	509	1976
140 3P	429	384	199	153	1165	1116	1039	1982	507	1872
85 1PT	385	360	260	235	1239	1031	1039	1382	527	1319
95 1PT	394	369	258	233	1254	1046	1039	1382	527	1330
105 1PT	397	372	265	240	1274	1064	1039	1382	527	1324
115 1PT	401	374	266	240	1281	1071	1039	1382	526	1325
125 1PT	454	436	310	292	1492	1135	1039	1982	536	1671
140 1PT	429	409	343	323	1504	1147	1039	1982	534	1593
85 2PT	391	359	270	238	1257	1050	1039	1382	521	1313
95 2PT	400	368	268	236	1272	1064	1039	1382	522	1324
105 2PT	404	372	275	243	1293	1083	1039	1382	522	1318
115 2PT	407	374	276	243	1299	1090	1039	1382	521	1319
125 2PT	462	438	318	294	1512	1155	1039	1982	531	1668
140 2PT	437	410	352	325	1524	1167	1039	1982	529	1591

* Dimensions are referred to unit with antivibration mounted isolators.

Technical data

AQVH 85 - 140 Al/Cu Version BLN/ELN/HT

AQVH Al/Cu	Weight distribution				Operating weight	Shipping weight	P1-P4 coordinates*		CG coordinates	
	F1	F2	F3	F4			a	b	x	y
	kg	kg	kg	kg			mm	mm	mm	mm
85	416	412	132	129	1090	1065	1039	1382	544	1539
95	422	419	133	130	1105	1080	1039	1382	544	1542
105	431	434	141	143	1149	1122	1039	1382	550	1530
115	444	439	151	146	1180	1153	1039	1382	543	1523
125	435	432	182	179	1227	1196	1039	1982	545	1888
140	456	451	200	195	1301	1270	1039	1982	543	1870
85 1P	427	396	179	147	1150	1107	1039	1382	519	1479
95 1P	453	420	163	130	1165	1122	1039	1382	518	1524
105 1P	443	418	187	162	1209	1164	1039	1382	526	1473
115 1P	455	423	197	165	1240	1195	1039	1382	520	1467
125 1P	489	454	190	155	1289	1240	1039	1982	519	1940
140 1P	478	444	237	203	1363	1313	1039	1982	522	1830
85 2P	433	396	187	150	1166	1123	1039	1382	514	1472
95 2P	458	419	171	132	1181	1138	1039	1382	513	1516
105 2P	449	418	195	164	1225	1180	1039	1382	521	1466
115 2P	461	422	206	167	1256	1211	1039	1382	516	1461
125 2P	497	456	198	156	1307	1257	1039	1982	515	1934
140 2P	486	446	245	205	1380	1331	1039	1982	517	1826
85 3P	434	394	198	158	1183	1141	1039	1382	512	1456
95 3P	459	417	182	140	1198	1156	1039	1382	511	1500
105 3P	450	416	206	172	1243	1198	1039	1382	519	1451
115 3P	462	420	216	175	1273	1229	1039	1382	514	1447
125 3P	500	456	207	162	1326	1277	1039	1982	513	1919
140 3P	489	446	254	211	1399	1350	1039	1982	516	1813
85 1PT	415	392	291	268	1367	1159	1039	1382	530	1306
95 1PT	440	416	275	251	1382	1174	1039	1382	529	1345
105 1PT	431	414	299	282	1426	1216	1039	1382	535	1308
115 1PT	443	419	310	285	1457	1247	1039	1382	530	1307
125 1PT	500	481	351	333	1665	1308	1039	1982	536	1657
140 1PT	488	471	398	381	1739	1381	1039	1982	537	1583
85 2PT	421	392	301	271	1385	1178	1039	1382	525	1300
95 2PT	446	415	285	254	1400	1192	1039	1382	524	1340
105 2PT	437	414	309	285	1445	1235	1039	1382	531	1303
115 2PT	449	418	319	288	1475	1265	1039	1382	526	1302
125 2PT	508	483	360	334	1685	1328	1039	1982	532	1655
140 2PT	497	473	407	382	1759	1402	1039	1982	533	1582

* Dimensions are referred to unit with antivibration mounted isolators.

AQVH 85 - 140 Cu/Cu Version BLN/ELN/HT

AQVH Cu/Cu	Weight distribution				Operating weight	Shipping weight	P1-P4 coordinates*		CG coordinates	
	F1	F2	F3	F4			a	b	x	y
	kg	kg	kg	kg			mm	mm	mm	mm
85	469	465	186	182	1303	1278	1039	1382	544	1480
95	476	471	187	183	1317	1293	1039	1382	544	1483
105	489	500	199	210	1397	1370	1039	1382	556	1467
115	515	509	223	217	1463	1436	1039	1382	543	1455
125	504	500	251	247	1503	1471	1039	1982	545	1814
140	549	542	292	285	1668	1637	1039	1982	543	1785
85 1P	481	449	233	201	1363	1320	1039	1382	523	1432
95 1P	529	496	193	159	1377	1335	1039	1382	522	1517
105 1P	500	484	245	228	1457	1413	1039	1382	536	1422
115 1P	526	492	269	236	1523	1479	1039	1382	524	1413
125 1P	559	523	259	223	1564	1515	1039	1982	524	1859
140 1P	571	536	329	294	1730	1681	1039	1982	527	1756
85 2P	486	448	241	203	1379	1336	1039	1382	519	1426
95 2P	535	495	201	162	1393	1351	1039	1382	518	1511
105 2P	506	483	253	231	1473	1429	1039	1382	532	1417
115 2P	532	492	278	238	1539	1495	1039	1382	521	1408
125 2P	566	524	267	224	1582	1533	1039	1982	520	1855
140 2P	578	537	337	296	1748	1699	1039	1982	523	1754
85 3P	487	447	252	211	1396	1354	1039	1382	517	1413
95 3P	536	493	212	170	1411	1368	1039	1382	516	1497
105 3P	507	482	264	238	1491	1446	1039	1382	530	1405
115 3P	533	490	288	246	1557	1512	1039	1382	519	1397
125 3P	570	524	276	231	1601	1552	1039	1982	518	1843
140 3P	582	537	346	302	1767	1718	1039	1982	521	1744
85 1PT	468	445	345	321	1580	1372	1039	1382	532	1288
95 1PT	517	492	305	280	1594	1387	1039	1382	531	1364
105 1PT	488	480	357	349	1674	1465	1039	1382	542	1288
115 1PT	514	489	382	356	1740	1531	1039	1382	532	1285
125 1PT	569	550	420	401	1940	1583	1039	1982	537	1632
140 1PT	581	563	490	472	2106	1749	1039	1982	538	1566
85 2PT	475	444	355	324	1598	1390	1039	1382	528	1284
95 2PT	523	491	315	283	1613	1405	1039	1382	527	1358
105 2PT	494	479	367	352	1693	1483	1039	1382	538	1284
115 2PT	520	488	391	359	1759	1549	1039	1382	529	1281
125 2PT	578	551	429	402	1960	1603	1039	1982	533	1631
140 2PT	590	564	499	473	2126	1769	1039	1982	535	1565

* Dimensions are referred to unit with antivibration mounted isolators.

Technical data

AQVC 85 - 140 Al/Cu Version BLN/ELN/HT

AQVC Al/Cu	Weight distribution				Operating weight	Shipping weight	P1-P4 coordinates*		CG coordinates	
	F1	F2	F3	F4			a	b	x	y
	kg	kg	kg	kg			mm	mm	mm	mm
85	385	384	101	100	971	971	1039	1382	547	1584
95	391	390	101	101	983	983	1039	1382	547	1587
105	395	403	104	111	1013	1013	1039	1382	555	1578
115	408	407	114	114	1043	1043	1039	1382	547	1569
125	384	385	148	149	1066	1066	1039	1982	549	1920
140	406	405	166	165	1142	1142	1039	1982	547	1897

AQVC 85 - 140 Cu/Cu Version BLN/ELN/HT

AQVC Cu/Cu	Weight distribution				Operating weight	Shipping weight	P1-P4 coordinates*		CG coordinates	
	F1	F2	F3	F4			a	b	x	y
	kg	kg	kg	kg			mm	mm	mm	mm
85	438	437	155	154	1183	1183	1039	1382	546	1511
95	444	443	155	154	1196	1196	1039	1382	546	1514
105	453	468	162	178	1261	1261	1039	1382	560	1499
115	479	477	186	185	1326	1326	1039	1382	546	1484
125	454	454	217	217	1342	1342	1039	1982	548	1830
140	499	496	258	256	1509	1509	1039	1982	546	1796

AQVC 85 - 140 MCHX

AQVC MCHX	Weight distribution				Operating weight	Shipping weight	P1-P4 coordinates*		CG coordinates	
	F1	F2	F3	F4			a	b	x	y
	kg	kg	kg	kg			mm	mm	mm	mm
85	358	358	74	74	864	864	1039	1382	547	1635
95	364	364	74	74	876	876	1039	1382	547	1637
105	366	366	74	74	880	880	1039	1382	549	1639
115	368	368	74	74	884	884	1039	1382	547	1639
125	349	351	113	115	928	928	1039	1982	550	1985
140	354	354	114	114	935	935	1039	1982	547	1988

* Dimensions are referred to unit with antivibration mounted isolators.

AQVC Refrigerant Lines

AQVC	Line length	ø Suction line		ø Liquid line		R410A kg/m
	m	inch	mm	inch	mm	
85	10	1"3/8	34,93	7/8"	22,23	0,34
	20	1"3/8	34,93	7/8"	22,23	0,34
	30	1"3/8	34,93	7/8"	22,23	0,34
95	10	1"3/8	34,93	7/8"	22,23	0,34
	20	1"3/8	34,93	7/8"	22,23	0,34
	30	1"3/8	41,28	7/8"	22,23	0,35
105	10	1"3/8	34,93	7/8"	22,23	0,34
	20	1"3/8	34,93	7/8"	22,23	0,34
	30	1"5/8	41,28	7/8"	22,23	0,35
115	10	1"3/8	34,93	1"1/8	28,58	0,53
	20	1"3/8	34,93	1"1/8	28,58	0,53
	30	1"5/8	41,28	1"1/8	28,58	0,54
125	10	1"3/8	34,93	1"1/8	28,58	0,53
	20	1"3/8	34,93	1"1/8	28,58	0,53
	30	1"5/8	41,28	1"1/8	28,58	0,54
140	10	1"3/8	34,93	1"1/8	28,58	0,53
	20	1"5/8	41,28	1"1/8	28,58	0,54
	30	1"5/8	41,28	1"1/8	28,58	0,54

AQVC125: Max distance: consider 30mt. 30mt Suction line + 30mt Liquid line.

Each refrigerant circuit needed to add 0.53kg / mt of distance. In example in case of 30mt distance between AQVC and evaporator, for each circuit consider 30x0.53kg = 15.9kg per circuit.

8.6 Dimensional Drawings

Units AQVL/AQVH 85-115 R410A

BOTTOM VIEW

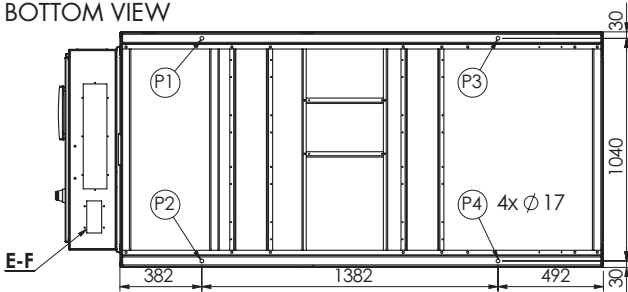

FRONT VIEW

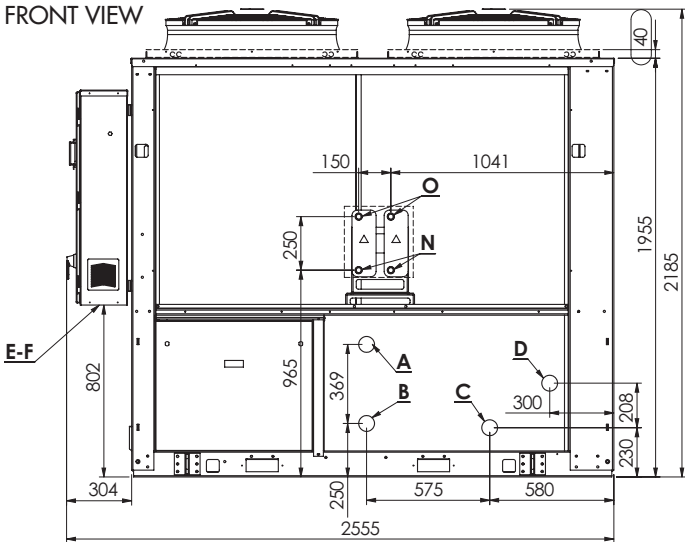

SIDE VIEW

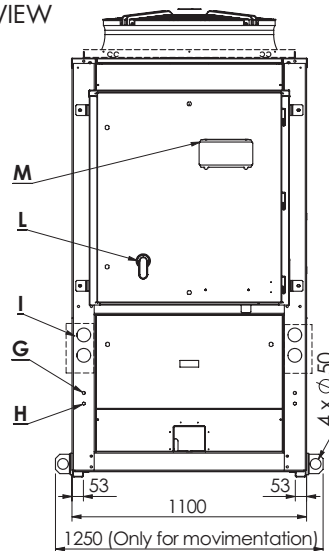

TOP VIEW

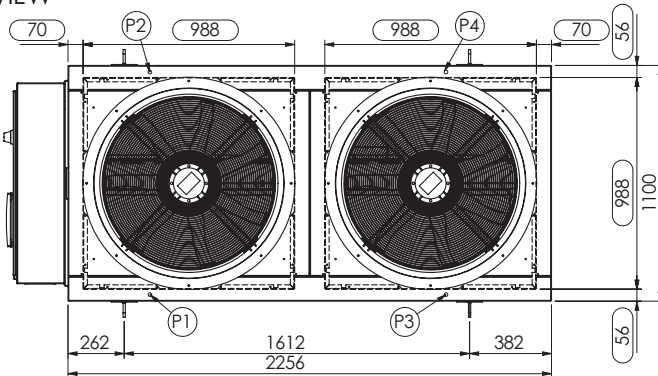

Notes:

- A B C D WATER CONNECTION 2 1/2" GAS M.
- E ELECTRICAL AUXILIARY LINES
- F ELECTRICAL POWER SUPPLY
- G HIGH PRESSURE TAP
- H LOW PRESSURE TAP
- I GAUGE KIT (ACCESSORY)
- L MAIN SWITCH
- M CONTROL KEYPAD / DISPLAY

Optional:

- N DESUPERHEATER WATER INLET 1" GAS M.
- O DESUPERHEATER WATER OUTLET 1" GAS M.

P1, P2, P3, P4 AVM POSITION

Hydraulic option	Water in	Water out
STD	A	B
1P/2P/3P	C	B
1P+T/2P+T	C	D

Technical data

Units AQVL/AQVH 125-140 R410A

BOTTOM VIEW

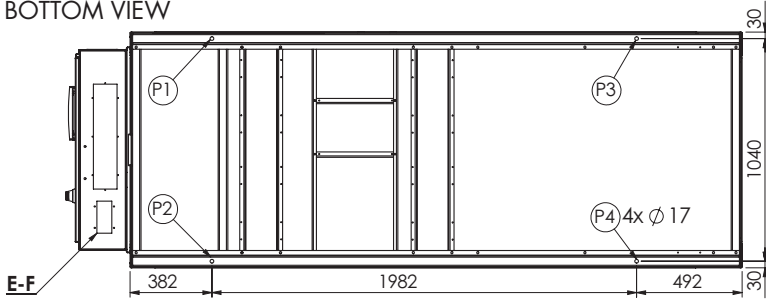

FRONT VIEW

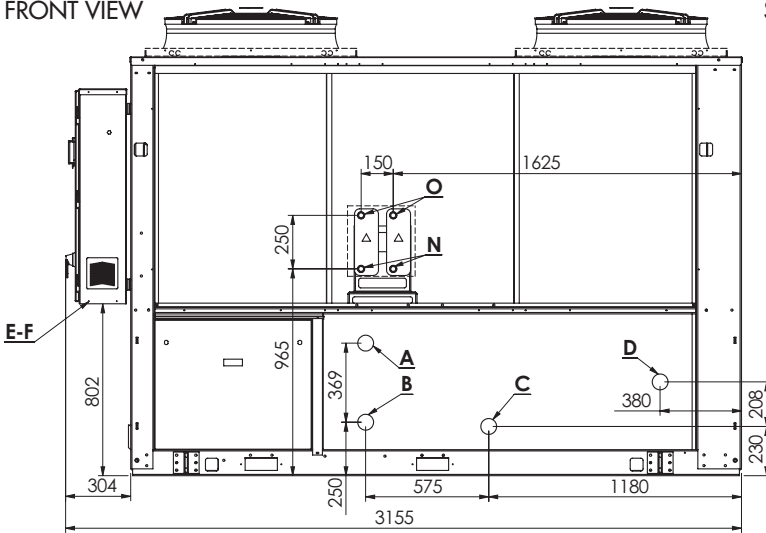

SIDE VIEW

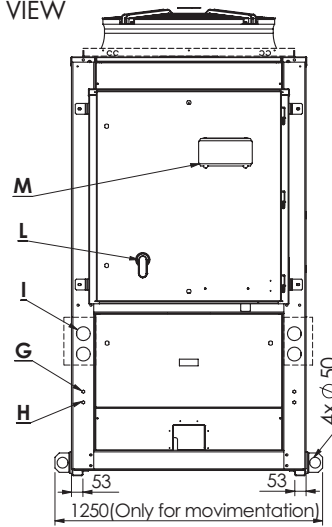

TOP VIEW

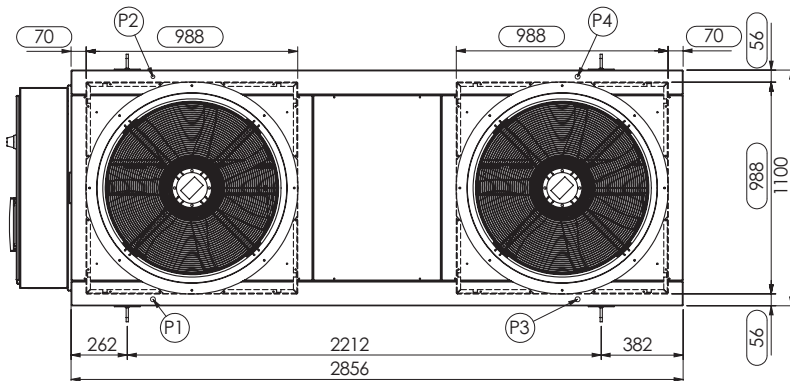

Notes:

- A B C D WATER CONNECTION 2 1/2" GAS M.
- E ELECTRICAL AUXILIARY LINES
- F ELECTRICAL POWER SUPPLY
- G HIGH PRESSURE TAP
- H LOW PRESSURE TAP
- I GAUGE KIT (ACCESSORY)
- L MAIN SWITCH
- M CONTROL KEYPAD / DISPLAY

Optional:

- N DESUPERHEATER WATER INLET 1" GAS M.
- O DESUPERHEATER WATER OUTLET 1" GAS M.

P1, P2, P3, P4 AVM POSITION

Hydraulic option	Water in	Water out
STD	A	B
1P/2P/3P	C	B
1P+T/2P+T	C	D

8.7 Service spaces

AQVL/AQVC/AQVH/AQVR All models

Installation of Single Units

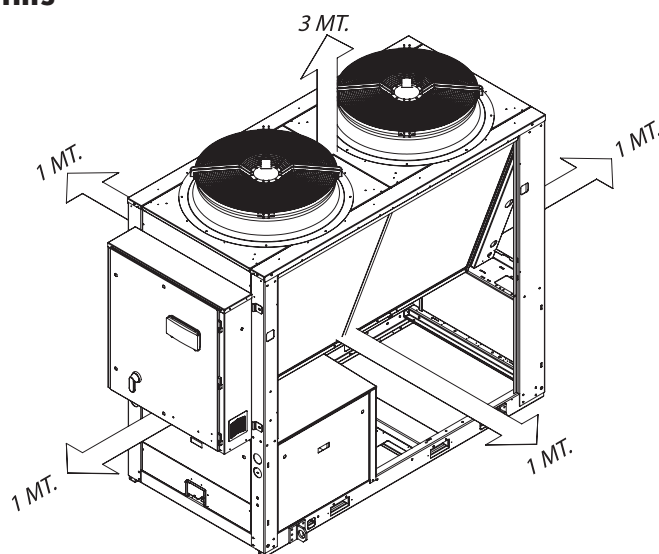

Installation of Several Units

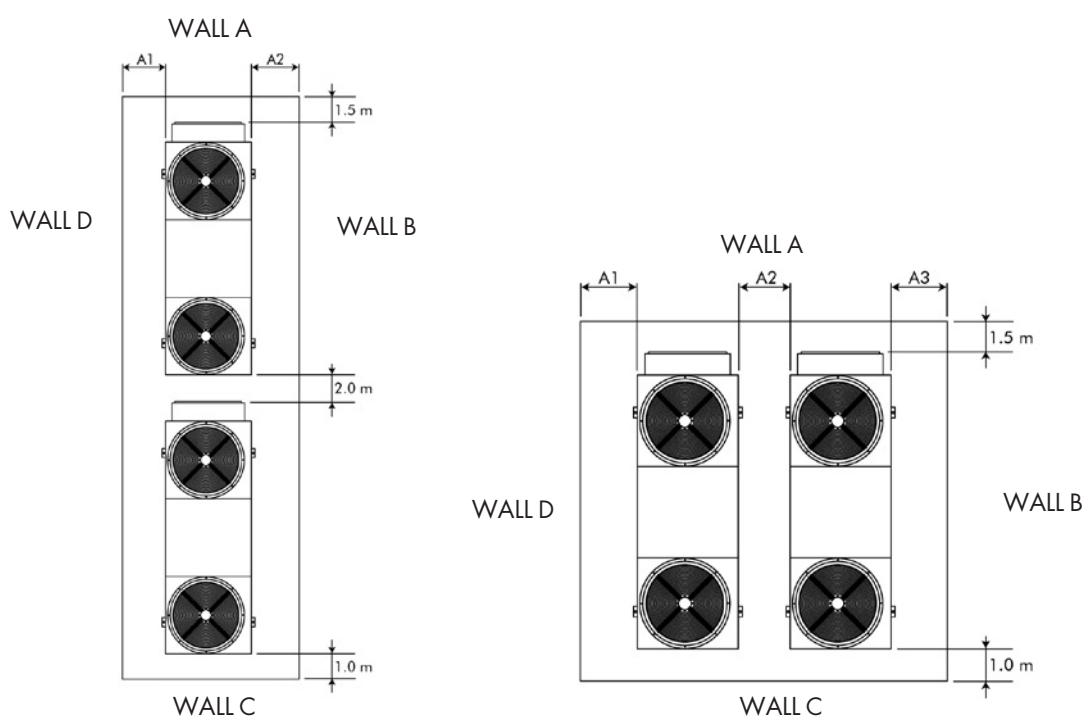

ARRANGEMENT 1

ARRANGEMENT 2

	A and C GRILLE B and D FULL			A and B FULL C and D FULL			A and C FULL B and D GRILLE			A and B GRILLE C and D FULL			A and D GRILLE B and C FULL		
	A1 (mm)	A2 (mm)	A3 (mm)	A1 (mm)	A2 (mm)	A3 (mm)	A1 (mm)	A2 (mm)	A3 (mm)	A1 (mm)	A2 (mm)	A3 (mm)	A1 (mm)	A2 (mm)	A3 (mm)
Arrangement 1 (m)	1000	1000		1000	1000		800	800		1000	800		800	1000	
Arrangement 2 (m)	1000	1500	1000	1000	2000	1000	800	2000	800	1000	1500	800	800	1500	1000

A wall only may be higher than the units.
The area between the walls must be kept free from any obstacle which may hinder the free air inflow towards the unit(s).

9 MAINTENANCE

Carefully read the “Safety” section of this manual before carrying out any maintenance operations.



Do not discharge the refrigerant into the atmosphere while the refrigeration circuits are being drained. Use appropriate recovery equipment. When the recovered refrigerant cannot be re-used, return it to the manufacturer.



Do not throw away the waste oil of the compressor, because it contains refrigerant in solution. The waste oil must be returned to the manufacturer.

Unless otherwise specified, the operations described below may be carried out only by a trained maintenance operator.

9.1 General requirements

Units have been designed for continuous operation, providing that they are subjected to regular maintenance, within the limits specified in this manual. Each unit must be serviced according to the programme by the User/Customer, and must be inspected at regular intervals by the personnel of one authorised Service Centers.

It is the responsibility of the User to meet these maintenance requirements and/or to enter into an agreement with one of authorised Service Centers, so as to properly safeguard the operation of the appliance.

During the warranty period, in case of damage or failures caused by improper maintenance, manufacturer will not refund the costs incurred to repair the appliance in its original state.

The provisions of this section apply only to standard units; according to the order requirements, other documentation may be added, concerning any modifications or supplementary accessories.

9.2 Planned maintenance

Maintenance inspections must be carried out according to the program below, by a qualified person. As a general rule, units cannot be repaired directly by the user, who shall not try to service or repair any failures or anomalies identified during daily inspections. If you are in doubt, please contact authorised Service Centre.

Planned maintenance

Operations	Daily	Weekly	Monthly	Beginning of season	End of season
Check the temperature of the leaving fluid	●				
Check the pressure drops in the heat exchanger		●			
Check for electric absorption		●			
Check suction pressure and temperature		●			
Check delivery pressure and temperature		●			
Check the oil level in the compressor		●			
Check that there are no gas bubbles in the liquid line		●			
Check that the fins of the external coil are clean (if any)			●		
Check the operation of the oil heaters			●		
Check the remote control switches			●		
Check the operation of the LP pressure switch				●	
Check the operation of the HP pressure switch				●	
Check the insulation of the heat exchanger				●	
Check that terminals are tightened				●	
Check that the terminals' screws are tightened				●	
Clean the exterior of the unit with water and soap				●	
Check the density of the antifreeze (if any)				●	●
Check the operation of the flow switches				●	
Check the operation of the solenoid valve				●	●

9.3 Refrigerant charge



Do not inject refrigerant liquid into the LP side of the circuit. Be very careful, and charge the circuit properly. If the charge is insufficient, the efficiency of the unit will be lower than expected. (In the worst of cases the LP transducer may stop the unit.)

In the presence of an excess charge, the condensing pressure will rise (in the worst of cases, the HP pressure switch may be activated, resulting in the stop of the equipment), and the consumption will increase as well.



It is strictly forbidden to use the compressor as a vacuum pump to drain the plant.

Fill the refrigeration circuit after it has been drained for maintenance purposes (leaks, replacement of the compressor etc.). The amount of the charge is indicated on the plate affixed to the unit.

Before refilling, it is important to drain and de-hydrate the circuit, thus obtaining a minimum abs. pressure value of 50 Pa.

Inject the refrigerant fluid before removing the vacuum, then fill the circuit up to 90% of the total gas requirement (in liquid form). The appliance must be filled through the filling valve on the liquid line, on the outlet side of the condenser.

It is recommended to connect the refrigerant cylinder to the filling valve on the liquid line, and to arrange it in such a way as to inject only liquid refrigerant.

9.4 Compressor

Compressors are delivered with the necessary charge of lubricating oil. During normal operation, this charge is sufficient for the whole life of the unit, providing that the efficiency of the refrigeration circuit is satisfactory and if it has not been overhauled.

If the compressor needs to be replaced (following a mechanical failure or if burnt), contact one of authorised Service Centers.



Compressors use polyester oil. During maintenance operations on the compressor, or if you have to open the refrigerant circuit in any point, remember that this type of oil is highly hygroscopic, and accordingly it is important that it is not left exposed to the weather for prolonged periods, as this

would require the replacement of the oil.

In a few cases, the polyester oil may be present also in R22 units (a refrigerant that can be used also in extra UE countries).

9.5 Condenser

The condenser's coils consist of copper pipes and aluminium fins. In the presence of leaks caused by any damage or shock, the coils shall be repaired or replaced by one of authorised Service Centers. To ensure the effective and correct operation of the condenser coils, it is important to keep the condenser's surface perfectly clean, and to check that there is no foreign matter, such as leaves, wires, insects, waste etc. If the coil becomes dirty, there is an increase in the absorption of electric energy. Furthermore, the maximum pressure alarm may be activated and may halt the unit.



Be careful not to damage the aluminium fins during cleaning.

The condenser must be cleaned with a LP compressed air jet, parallel to the aluminium fins, in the direction opposite to the air circulation.

To clean the coil you can use also a vacuum cleaner, or a jet of water and soap.

9.6 Fans

The fans of the condenser, of axial type, are complete with impeller with aerodynamic profile blades and a cylindrical nozzle. The motor's bearings are lubricated forever.

9.7 Dehydrating filter

The refrigeration circuits are provided with dehydrating filters.

The filter clogging is marked by the presence of air bubbles in the sight glass, or by the difference between the temperatures measured downstream from and upstream of the drying filter. If, once the cartridge has been cleaned, there are still some air bubbles, the appliance has lost a part of the refrigerant charge in one or more points, that must be identified and serviced.

9.8 Sight glass

The sight glass is used for inspecting the refrigerant

flow and the humidity % of the refrigerant. The presence of bubbles indicates that the dehydrating filter is clogged or the charge insufficient.

A colour indicator is positioned inside the sight glass. If you compare the colour of the indicator to the scale on the ring of the sight glass, you can calculate the percentage of humidity of the refrigerant. If it is excessive, replace the filter's cartridge, operate the appliance for 1 day and then check the humidity % again. When the humidity % is within the pre-determined range, no other operations are required. If the humidity % is still too high, replace the dehydrating filter again, start the unit and operate it for another day.

To obtain an effective heat exchange, the difference between the temperature of the leaving water and the saturated evaporating temperature must be in the 2 - 4°C range. A greater difference would indicate a low efficiency of the heat exchanger (i.e. the heat exchanger is dirty).

In this case, the heat exchanger must be subjected to chemical cleaning, an operation that shall be carried out by authorised engineers.

For other maintenance operations (extraordinary overhauling, replacement of the heat exchanger etc.), contact an authorised Service Centre.

9.9 Electronic expansion valve

The circuit of the unit is equipped with a electronic expansion valve, with external equalizer
The valve is factory calibrated for an overheating of 5°C.
Procedure to check for overheating:

- Measure the suction pressure with the pressure gauges on the board of the unit or using a pressure gauge connected to the service valve on the suction side.
- From the pressure gauge's temperature scale, measure the saturated suction temperature (T_{sa}) which corresponds to the pressure value.
- Using a contact pressure gauge affixed to the outlet fitting of the gas of the evaporator, measure the actual temperature (T_{se}).

Overheating calculation (S):

$$S = T_{se} - T_{sa}$$

Overheating is regulated through the electronic expansion valve.

Make the adjusting screw follow a complete turn, and operate the appliance for five minutes.
Check again and, if necessary, repeat the regulation.

If the expansion valve cannot be regulated, it is probably broken, and shall be replaced. The replacement must be carried out by a Service Centre.

9.10 Evaporator

Check at regular intervals that the water side of the heat exchanger is perfectly clean. To do this, measure the pressure drop, water side (see Section 8) or measure the temperature of the liquid leaving and entering the heat exchanger, and compare it to the evaporation temperature.

10 TROUBLESHOOTING

The table below lists the anomalies of operation of the unit, the relevant causes and the corrective measures. For anomalies of any other type or not listed, contact one of authorised Service Centre for technical assistance.

Anomaly	Cause	Operation
The unit continues to work, but without cooling.	Insufficient charge of refrigerant.	Refill.
	The dehydrating filter is clogged.	Replace.
Ice on the suction line.	Wrong calibration of overheating.	Increase overheating.
		Check the charge.
Excessive noise.	Vibration of lines.	Check the clamping brackets, if any.
	Whistler emitted by the thermostatic expansion valve.	Refill.
		Check the dehydrating filter.
	Noisy compressor.	Seized bearings; replace the compressor.
Check that the compressor's locknuts are tightened.		
Low oil level in the compressor.	One or more gas or oil leaks in the circuit.	Identify and remove leaks.
	Mechanical failure of the compressor.	Request the intervention of a Service Centre.
	Anomaly of the oil heater of the compressor's base.	Check the electric circuit and the resistor of the heater of the motor base, and replace defective components.
One or both compressors are not working.	Breaking of the electric circuit.	Check the electric circuit and detect any ground dispersions and short circuits. Check fuses.
	Intervention of the HP pressure switch.	Reset the pressure switch and the control panel and restart the appliance. Identify and remove the cause that enabled the pressure switch.
	The fuse of the control circuit is broken.	Check for ground dispersions and short circuits. Replace fuses.
	Loosened terminals.	Check and tighten.
	Halt caused by thermal overload of the electric circuit.	Check the operation of check and safety devices. Identify and remove the cause.
	Wrong wiring.	Check wiring of check and safety devices.
	The line voltage is too low.	Check voltage. If problems regard the system, solve them. If they are caused by the distribution network, inform the Energy Distributor.
	Short-circuit of the compressor's motor.	Check the continuity of the winding.
	Seized compressor.	Replace the compressor.
Activation of the LP alarm, stop of the unit.	Gas leak.	Identify and remove the leak.
	Insufficient charge.	Refill.
	Failure of the pressure switch.	Replace the pressure switch.

Troubleshooting

Anomaly	Cause	Operation
Activation of the HP alarm, stop of the unit.	Failure of the pressure switch.	Check the operation of the pressure switch, replace it if defective.
	The delivery valve is partially closed.	Open the valve and replace it, if faulty.
	Substances with condensable gases in the circuit.	Drain the circuit.
	The fan of the condenser is stopped.	Check cables and motor. If defective, repair or replace.
The liquid line is too hot.	Insufficient charge.	Identify and remove the cause of the loss of charge and refill.
Frosting of the liquid line.	The valve of the liquid line is partially closed.	Check that valves are open.
	The liquid filter is clogged.	Replace the cartridge or the filter.

Spare parts

11 SPARE PARTS

11.1 Spare part list

The table below shows the list of spare parts recommended during the first two years of operation.

Component	Number
Fan	2
Differential water pressure switch	1
High pressure transducer	2
Low pressure transducer	4
Electronic expansion valve	2
Gas filter	2
4 way valve	2
Electronic main board	1
Auxiliary circuit transformer	1
Compressor contactor	2
Pump contactor	1
Water sensor	4
Air sensor	1
Auxiliary contact	4
Driver EEV	2
Fuses	4

11.2 Oil for compressors

The compressors are lubricated with polyester oil (P.O.E.).

11.3 Wiring diagrams

The wiring diagrams are installed inside the doors of the electrical panels of the unit. Any request for wiring diagrams shall be forwarded to manufacturer's Service Centre.

12 DISMANTLING, DEMOLITION AND SCRAPPING



During the draining of the refrigeration circuits, do not let the refrigerant overflow in the surrounding atmosphere. The circuit must be drained using suitable recovery equipment.



Do not disperse the waste oil of the compressors in the environment, since it contains some dissolved refrigerant.

For the disposal, contact the competent authority for information.

Unless otherwise specified, the maintenance operations listed below may be carried out by any trained maintenance operator.

12.1 Generalities

Open each line that supplies the unit, including the ones of control circuits. Make sure that all disconnecting switches are secured in the off position. The power cables can be disconnected and disassembled. Refer to Chapter 4 for the position of connection points.

Remove all the refrigerant from the refrigeration circuits of the unit and store it in suitable containers, using a recovery unit. If its characteristics have remained the same, the refrigerant can be used again. Contact the competent authority to obtain information about disposal. In **NO** event shall the refrigerant be discharged into the atmosphere. The oil in each refrigeration circuit must be drained and collected into a suitable container; then it shall be disposed of in conformity with local regulations that apply to the disposal of waste lubricants. Any oil spillage must be recovered and disposed of in like manner.

Isolate the unit's heat exchangers from the external hydraulic circuits and drain the heat exchange sections of the plant.



If no shutoff valves have been provided, it may be necessary to drain the whole plant. If a glycoled solution or a similar fluid has been used in the hydraulic circuits, or if chemical additives have been added to the circulating water, the circulating fluid **MUST** be drained in a proper way. For **NO** reason shall a circuit containing glycoled water or a similar solution be discharged directly into the drains or surface waters.

After draining operations, the piping of the hydraulic networks can be disconnected and disassembled.

Once they have been disconnected as specified, the packaged units can be disassembled in a single piece. First of all, disassemble the anchoring screws and then lift the unit from the position of installation, and hook it to the lifting points provided, using suitable lifting equipment.

To this end, refer to Chapter 4 for the installation of these appliances, to Chapter 8 for their weights and Chapter 3 for handling.

The units that, once disconnected, cannot be removed in a single piece, must be dismantled on site; in this case, be very careful with the weight and handling of every single component.

It is always advisable to dismantle the units following the installation steps, but in reverse.



Some residues of oil, glycoled water or similar solutions may remain in certain parts of the unit. These residues must be recovered and disposed of according to the procedures specified above.

It is very important to ensure that, while a component of the unit is being removed, all the others are properly supported.



Use only lifting means of adequate capacity.

Once disassembled, the components of the unit can be disposed of in conformity with current regulations.

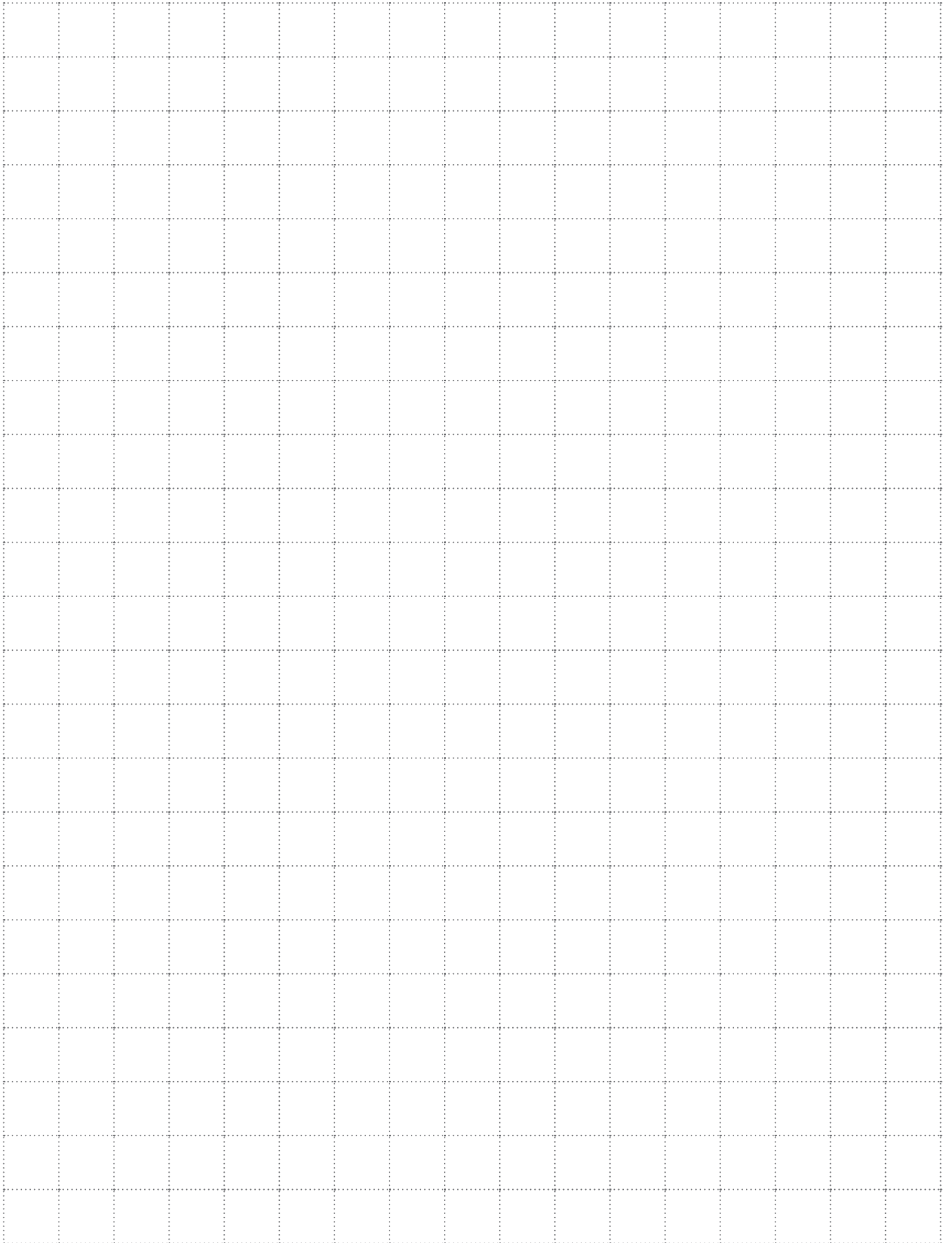

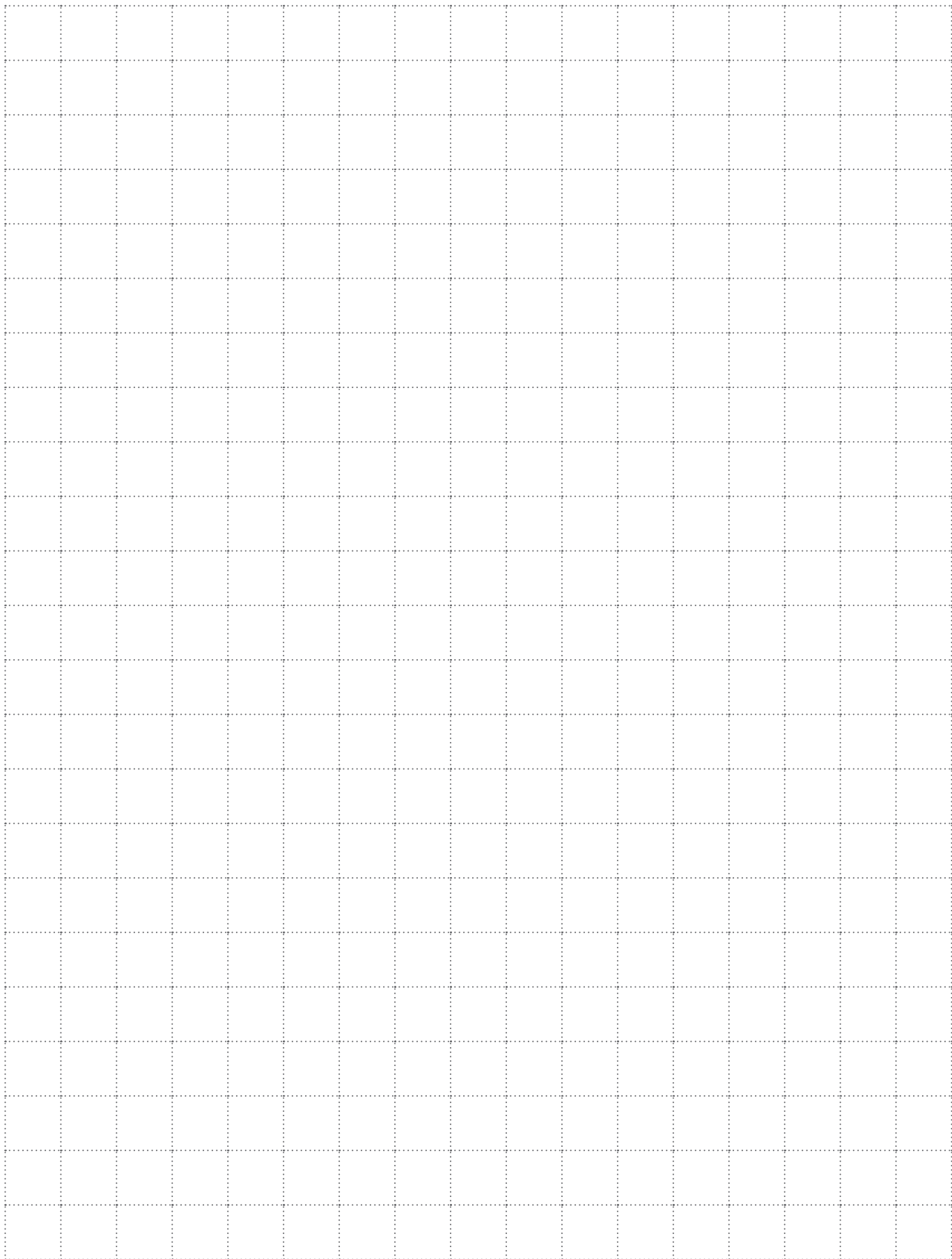

BUONE NORME DI MANUTENZIONE DEI DISPOSITIVI DI SICUREZZA MONTATI SUL GRUPPO FRIGORIFERO

Gentile Cliente,

Le ricordiamo alcune indicazioni circa le modalità di manutenzione dei dispositivi di sicurezza montati sul gruppo frigorifero da Lei acquistato.

I dispositivi di sicurezza montati sul gruppo sono stati verificati dal COSTRUTTORE a norma di legge.

È opportuno che l'utente provveda periodicamente (è consigliato ogni anno) a far verificare da personale qualificato la taratura ed il corretto intervento dei dispositivi di sicurezza montati sul gruppo.

In particolare la taratura della/e valvole di sicurezza dovrebbe essere verificata al banco intercettando opportunamente il circuito e/o il refrigerante e registrando l'avvenuta verifica sulla scheda di manutenzione del gruppo frigorifero (a disposizione dei tecnici CE/PED che eventualmente ne prenderanno visione).

L'utente avrà cura di conservare efficienti ed in buono stato l'evaporatore ed i suoi accessori e provvederà ad eventuali sostituzioni degli stessi con altri di tipo analogo.

In caso di sostituzione, la valvola di sicurezza e i pressostati di alta pressione dovranno avere caratteristiche equivalenti a quelle fornite e rilasciate con certificato CE/PED.

Si consiglia in occasione della verifica delle valvole di sicurezza di far controllare il corretto intervento dei pressostati di alta pressione.

Per informazioni circa le modalità operative, la strumentazione e la scelta di personale qualificato, è possibile contattare IL COSTRUTTORE.

IMPORTANT NOTICE – Maintenance instructions

Please read carefully the following instructions for the maintenance of safety devices fitted on this refrigeration machine.

All safety devices fitted on the machine by MANUFACTURE have been checked and tested in accordance with European Regulations.

The machine has been designed to operate continuously provided it is regularly maintained and operated within the limitations given in the "Installation, Commissioning, Operation and Maintenance Manual". The unit should be maintained in accordance with the schedule by the operator/customer, backed up regular service and maintenance visit by an authorised service Centre.

It is the responsibility of the owner to provide for these regular maintenance requirements by a competent person. If in any doubt contact your local Service Centre.

In particular, all safety valves where fitted and safety pressure switches should be tested and calibrated. Where necessary test certificate provided by a certified authority must be retained as a record together with the Maintenance Log.

Date: 18/01/2012

Nazareno Mantovani

Quality / Service Director



As part of our ongoing product improvement programme, our products are subject to change without prior notice. Non contractual photos.

Dans un souci d'amélioration constante, nos produits peuvent être modifiés sans préavis. Photos non contractuelles.

In dem Bemühen um ständige Verbesserung können unsere Erzeugnisse ohne vorherige Ankündigung geändert werden. Fotos nicht vertraglich bindend.

A causa della politica di continua miglioria posta in atto dal costruttore, questi prodotti sono soggetti a modifiche senza alcun obbligo di preavviso. Le foto pubblicate non danno luogo ad alcun vincolo contrattuale.

Con objeto de mejorar constantemente, nuestros productos pueden ser modificados sin previo aviso. Fotos no contractuales.

