

Installation and maintenance manual
Manuel d'installation et de maintenance
Installations- und Wartungshandbuch
Manuale di installazione e di manutenzione
Manual de instalación y de mantenimiento

SyScroll Air CO/RE/HP/TR

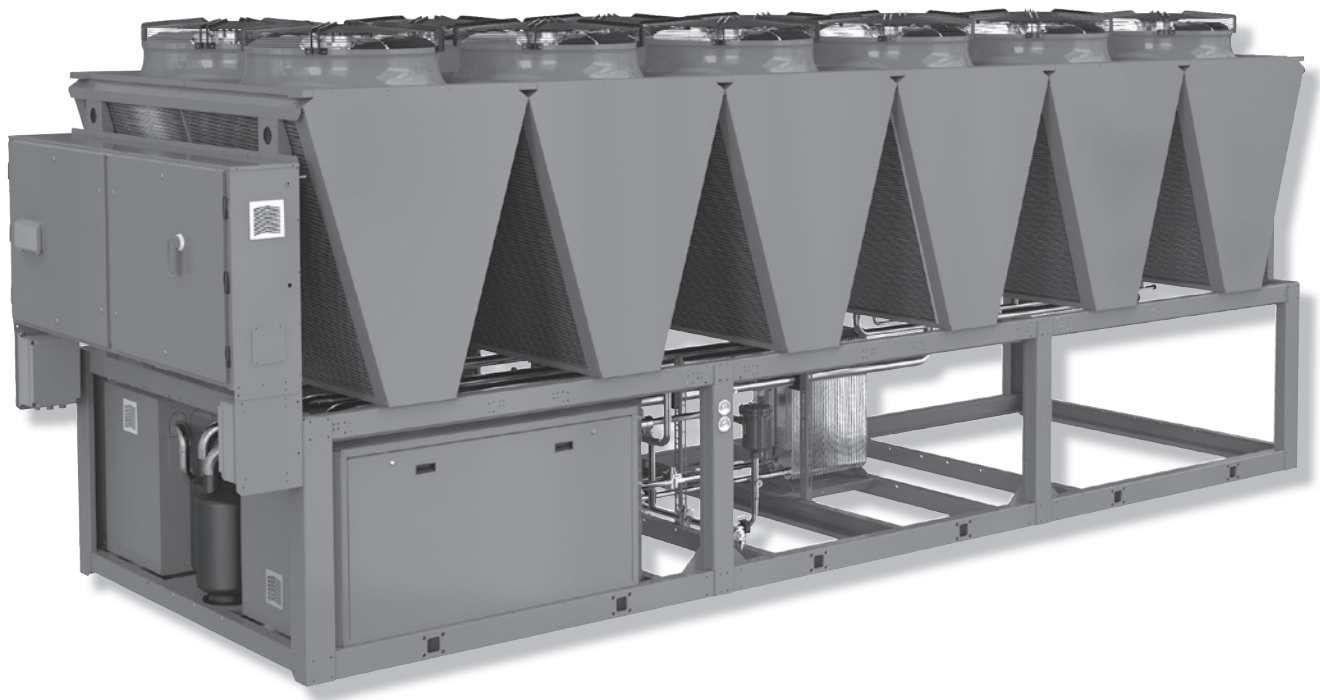

English

Français

Deutsch

Italiano

Español



238
↓
654 kW



256
↓
679 kW



Air Cooled Water Chillers and Heat Pumps

Refroidisseurs de liquide à condensation par air et pompes à chaleur air-eau

Luftgekühlte Flüssigkeitskühler und Wärmepumpen

Refrigeratori d'Acqua e Pompe di Calore Raffreddati ad Aria

Enfriadores de Agua y Bomba de Calor Condensadas con Aire

Part number / Code / Code / Codice / Código: **365088**

Supersedes / Annule et remplace / Annulliert und ersetzt / Annulla e sostituisce /

Anula y sustituye: **None / Aucun / Nicht / Nulla / Ninguno**

Notified Body / Organisme Notifié / Benannte Zertifizierungsstelle /

Organismo Notificato / Organismo Notificado N°. 1115 **PASCAL**



ISO 9001:2008 certified management system

Table of Contents

1 - FOREWORD

| | |
|---|---|
| 1.1 Introduction..... | 2 |
| 1.2 Warranty..... | 2 |
| 1.3 Emergency stop/Normal stop..... | 2 |
| 1.4 An introduction to this manual..... | 2 |

2 - SAFETY

| | |
|--|---------|
| 2.1 Foreword..... | 3 |
| 2.2 Definitions..... | 4 |
| 2.3 Access to the unit..... | 4 |
| 2.4 General precautions..... | 4 |
| 2.5 Precautions against residual risks..... | 4 |
| 2.6 Precautions during maintenance operations..... | 5 |
| 2.7 Safety labels..... | 6 & 7 |
| 2.8 Safety regulations..... | 8 to 10 |

3 - TRANSPORT, LIFTING AND POSITIONING

| | |
|---------------------|----|
| 3.1 Inspection..... | 11 |
| 3.2 Lifting..... | 11 |
| 3.3 Anchoring..... | 12 |
| 3.4 Storage..... | 12 |

4 - INSTALLATION

| | |
|--|----------|
| 4.1 Positioning of the unit..... | 13 |
| 4.2 Spring Isolator Installation..... | 13 |
| 4.3 External Water Circuit..... | 14 to 19 |
| 4.4 Water connections..... | 20 |
| 4.5 Defrost water drainage (only for HP units)..... | 20 |
| 4.6 Power supply..... | 20 |
| 4.7 Electrical connections..... | 21 |
| 4.8 Connecting plate-type evaporator temperature sensors..... | 21 & 22 |

5 - START-UP

| | |
|-----------------------------------|----|
| 5.1 Preliminary check..... | 23 |
| 5.2 Start-up..... | 23 |
| 5.3 Checking the operation..... | 23 |
| 5.4 Delivery to the customer..... | 23 |

6 - CONTROL

| | |
|--|----------|
| 6.1 The "Chiller Control" system..... | 24 |
| 6.2 Display..... | 25 |
| 6.3 Keyboard..... | 25 to 27 |
| 6.4 Protection and Safety Equipment..... | 28 |
| 6.5 HPF version configuration..... | 29 |

7 - PRODUCT DESCRIPTION

| | |
|---------------------------------------|----|
| 7.1 General Information..... | 30 |
| 7.2 Body and Frame..... | 30 |
| 7.3 Compressors..... | 30 |
| 7.4 Evaporators..... | 30 |
| 7.5 Condensing/evaporating coils..... | 30 |
| 7.6 Condenser Fans..... | 30 |
| 7.7 Fans Control..... | 30 |
| 7.8 Refrigerating Circuit..... | 30 |
| 7.9 Control Supply Panel..... | 30 |

8 - TECHNICAL DATA

| | |
|---|----------|
| 8.1 Pressure drops..... | 35 |
| 8.2 Technical data..... | 36 to 43 |
| 8.3 Unit electrical data..... | 44 & 45 |
| 8.4 Hydraulic Features..... | 46 to 50 |
| 8.5 Position of shock adsorbers and weight distribution on supports..... | 51 to 53 |
| 8.6 Dimensional Drawings..... | 54 to 57 |
| 8.7 Service requirements..... | 58 |

9 - MAINTENANCE

| | |
|-------------------------------------|----|
| 9.1 General requirements..... | 59 |
| 9.2 Planned maintenance..... | 59 |
| 9.3 Refrigerant charge..... | 60 |
| 9.4 Compressor..... | 60 |
| 9.5 Condenser..... | 60 |
| 9.6 Fans..... | 60 |
| 9.7 Dehydrating filter..... | 60 |
| 9.8 Sight glass..... | 60 |
| 9.9 Electronic expansion valve..... | 61 |
| 9.10 Evaporator..... | 61 |

10 - TROUBLESHOOTING

11 - SPARE PARTS

| | |
|-------------------------------|----|
| 11.1 Spare part list..... | 63 |
| 11.2 Oil for compressors..... | 63 |
| 11.3 Wiring diagrams..... | 63 |

12 - DISMANTLING, DEMOLITION AND SCRAPPING

| | |
|------------------------|----|
| 12.1 Generalities..... | 64 |
|------------------------|----|

1 - Foreword

1.1 Introduction

Units, manufactured to state-of-the-art design and implementation standards, ensure top performance, reliability and fitness to any type of air-conditioning systems.

These units are designed for cooling water or glycoled water (and for water heating in heat pump models) and are unfit for any purposes other than those specified in this manual.

This manual includes all the information required for a proper installation of the units, as well as the relevant operating and maintenance instructions.

It is therefore recommended to read this manual carefully before installation or any operation on the machine. The chiller installation and maintenance must be carried out by skilled personnel only (where possible, by one of Authorised Service Centers).

The manufacturer may not be held liable for any damage to people or property caused by improper installation, start-up and/or improper use of the unit and/or failure to implement the procedures and instructions included in this manual.

1.2 Warranty

These units are delivered complete, tested and ready for being operated. Any form of warranty will become null and void in the event that the appliance is modified without manufacturer's preliminary written authorisation.

This warranty shall apply providing that the installation instructions have been complied with (either issued by manufacturer, or deriving from the current practice), and the Form 1 ("Start-up") has been filled-in and mailed to manufacturer (attn. After-Sales Service).

In order for this warranty to be valid, the following conditions shall be met:

- The machine must be operated only by skilled personnel from Authorised After-Sales Service.
- Maintenance must be performed only by skilled personnel - from one of Authorised After-Sales Centers.
- Use only original spare parts.
- Carry out all the planned maintenance provided for by this manual in a timely and proper way.

Failure to comply with any of these conditions will automatically void the warranty.

1.3 Emergency stop / Normal stop

The emergency stop of the unit can be enabled using the master switch on the control panel (move down the lever).





For a normal stop, press the relevant push-buttons.

To restart the appliance, follow the procedure detailed in this manual.

1.4 An introduction to the manual

For safety reasons, it is imperative to follow the instructions given in this manual. In case of any damage caused by non-compliance with these instructions, the warranty will immediately become null and void.

Conventions used throughout the manual:

| | |
|---|--|
|  | The Danger sign recalls your attention to a certain procedure or practice which, if not followed, may result in serious damage to people and property. |
|  | The Warning sign precedes those procedures that, if not followed, may result in serious damage to the appliance. |
|  | The Notes contain important observations. |
|  | The Useful Tips provide valuable information that optimises the efficiency of the appliance. |

This manual and its contents, as well as the documentation which accompanies the unit, are and remain the property of manufacturer, which reserves any and all rights thereon. This manual may not be copied, in whole or in part, without manufacturer's written authorization.

2 - Safety

2.1 Foreword

These units must be installed in conformity with the provisions of Machinery Directive 2006/42/EC, Low Voltage Directive 2006/95/EC, Pressure Vessels Directive 97/23/EC, Electromagnetic Interference Directive 2004/108/EC, as well as with other regulations applicable in the country of installation. If these provisions are not complied with, the unit must not be operated.

| | |
|---|--|
|  | <p>The unit must be grounded, and no installation and/or maintenance operations may be carried out before deenergising the electrical panel of the unit.</p> |
|---|--|

Failure to respect the safety measures mentioned above may result in electrocution hazard and fire in the presence of any short-circuits.

| | |
|---|--|
|  | <p>Inside the heat exchangers, the compressors and the refrigeration lines, this unit contains liquid and gaseous refrigerant under pressure. The release of this refrigerant may be dangerous and cause injuries.</p> |
|---|--|

| | |
|---|---|
|  | <p>The units are not designed to be operated with natural refrigerants, such as hydrocarbons. Manufacturer may not be held liable for any problems deriving from the replacement of original refrigerant or the introduction of hydrocarbons.</p> |
|---|---|

Units are designed and manufactured according to the requirements of European Standard PED 97/23/EC (pressure vessels).

- The used refrigerants are included in group II (non-hazardous fluids).
- The maximum working pressure values are mentioned on the unit's data plate.
- Suitable safety devices (pressure switches and safety valves) have been provided, to prevent any anomalous overpressure inside the plant.
- The vents of the safety valves are positioned and oriented in such a way as to reduce the risk of contact with the operator, in the event that the valve is operated. Anyway, the installer will convey the discharge of the valves far from the unit.
- Dedicated guards (removable panels with tools) and danger signs indicate the presence of hot pipes or components (high surface temperature).

| | |
|---|---|
|  | <p>The guards of the fans (only for units provided with air heat exchangers) must be always mounted and must never be removed before de-energising the appliance.</p> |
|---|---|

| | |
|---|---|
|  | <p>It is the User's responsibility to ensure that the unit is fit for the conditions of intended use and that both installation and maintenance are carried out by experienced personnel, capable of respecting all the recommendations provided by this manual.</p> <p>It is important that the unit is adequately supported, as detailed in this manual. Non-compliance with these recommendations may create hazardous situations for the personnel.</p> |
|---|---|

| | |
|---|---|
|  | <p>The unit must rest on a base which meets the characteristics specified in this manual; a base with inadequate characteristics is likely to become a source of serious injury to the personnel.</p> |
|---|---|

| | |
|---|--|
|  | <p>The unit has not been design to withstand loads and/or stress that may be transmitted by adjacent units, piping and/or structures.</p> <p>Each external load or stress transmitted to the unit may break or cause breakdowns in the unit's structure, as well as serious dangers to people. In these cases, any form of warranty will automatically become null and void.</p> |
|---|--|

| | |
|---|--|
|  | <p>The packaging material must not be disposed of in the surrounding environment or burnt.</p> |
|---|--|

2 - Safety (continued)

2.2 Definitions

OWNER: means the legal representative of the company, body or individual who owns the plant where unit has been installed; he/she has the responsibility of making sure that all the safety regulations specified in this manual are complied with, along with the national laws in force.

INSTALLER: means the legal representative of the company who has been given by the owner the job of positioning and performing the hydraulic, electric and other connections of unit to the plant: he/she is responsible for handling and properly installing the appliance, as specified in this manual and according to the national regulations in force.

OPERATOR: means a person authorised by the owner to do on unit all the regulation and control operations expressly described in this manual, that must be strictly complied with, without exceeding the scope of the tasks entrusted to him.

ENGINEER: means a person authorised directly by manufacturer or, in all EC countries, excluding Italy, under his full responsibility, by the distributor of product, to perform any routine and extraordinary maintenance operations, as well as any regulation, control, servicing operations and the replacement of pieces, as may be necessary during the life of the unit.

2.3 Access to the unit

The unit must be placed in an area which can be accessed also by OPERATORS and ENGINEERS; otherwise the unit must be surrounded by a fence at not less than 2 meters from the external surface of the machine.

OPERATORS and ENGINEERS must enter the fenced area only after wearing suitable clothing (safety shoes, gloves, helmet etc.). The INSTALLER personnel or any other visitor must always be accompanied by an OPERATOR.

For no reason shall any unauthorised personnel be left alone in contact with the unit.

2.4 General precautions

The OPERATOR must simply use the controls of the unit; he must not open any panel, other than the one providing access to the control module.

The INSTALLER must simply work on the connections between plant and machine; he must not open any panels of the machine and he must not enable any control.

When you approach or work on the unit, follow the precautions listed below:

- do not wear loose clothing or jewellery or any other accessory that may be caught in moving parts
- wear suitable personal protective equipment (gloves, goggles etc.) when you have to work in the presence of free flames (welding operations) or with compressed air
- if the unit is placed in a closed room, wear ear protection devices
- cut off connecting pipes, drain them in order to balance the pressure to the atmospheric value before disconnecting them,

disassemble connections, filters, joints or other line items

- do not use your hands to check for any pressure drops
- use tools in a good state of repair; be sure to have understood the instructions before using them
- be sure to have removed all tools, electrical cables and any other objects before closing and starting the unit again

2.5 Precautions against residual risks

Prevention of residual risks caused by the control system

- be sure to have perfectly understood the operating instructions before carrying out any operation on the control panel
- when you have to work on the control panel, keep always the operating instructions within reach
- start the unit only after you have checked its perfect connection to the plant
- promptly inform the ENGINEER about any alarm involving the unit
- do not reset manual restoration alarms unless you have identified and removed their cause

Prevention of residual mechanical risks

- install the unit according to the instructions provided in this manual
- carry out all the periodical maintenance operations prescribed by this manual
- wear a protective helmet before accessing the interior of the unit
- before opening any panelling of the machine, make sure that it is secured to it by hinges
- do not touch air condensation coils without wearing protective gloves
- do not remove the guards from moving elements while the unit is running
- check the correct position of the moving elements' guards before restarting the unit

Prevention of residual electrical risks

- connect the unit to the mains according to the instructions provided in this manual
- periodically carry out all the maintenance operations specified by this manual
- disconnect the unit from the mains by the external disconnecting switch before opening the electrical board
- check the proper grounding of the unit before start-up
- check all the electrical connections, the connecting cables, and in particular the insulation; replace worn or damaged cables

2 - Safety (continued)

- periodically check the board's internal wiring
- do not use cables having an inadequate section or flying connections, even for limited periods of time or in an emergency

Prevention of other residual risks

- make sure that the connections to the unit conform to the instructions provided in this manual and on the unit's panelling
- if you have to disassemble a piece, make sure that it has been properly mounted again before restarting the unit
- do not touch the delivery pipes from the compressor, the compressor and any other piping or component inside the machine before wearing protective gloves
- keep a fire extinguisher for electrical appliances near the machine
- Wear proper protections near the safety valves. Each valve conveying through piping may change the real intervention value
- remove and leak of fluid inside and outside the unit
- collect the waste liquids and dry any oil spillage
- periodically clean the compressor compartment, to remove any fouling
- do not store flammable liquids near the unit
- do not disperse the refrigerant and the lubricating oil into the environment
- weld only empty pipes; do not approach flames or other sources of heat to refrigerant pipes
- do not bend/hit pipes containing fluids under pressure

2.6 Precautions during maintenance operations

Maintenance operations can be carried out by authorised technicians only.

Before performing any maintenance operations:

- disconnect the unit from the mains with the external disconnecting switch

- place a warning sign "do not turn on - maintenance in progress" on the external disconnecting switch
- make sure that on-off remote controls are inhibited
- wear suitable personal protective equipment (helmet, safety gloves, goggles and shoes etc.)

To carry out any measurements or checks which require the activation of the machine:

- work with the electrical board open only for the necessary time
- close the electrical board as soon as the measurement or check has been completed
- for outdoor units, do not carry out any operations in the presence of dangerous climatic conditions (rain, snow, mist etc.)

The following precautions must be always adopted:

- do not scatter the fluids of the refrigeration circuit in the surrounding environment
- when replacing an eprom or electronic cards, use always suitable devices (extractor, antistatic bracelet, etc.)
- to replace a compressor, the evaporator, the condensing coils or any other weighty element, make sure that the lifting equipment is consistent with the weight to be lifted
- in air units with independent compressor compartment, do not access the fan compartment unless you have disconnected the machine by the disconnecting switch on the board and you have placed a warning sign "do not turn on - maintenance in progress"
- contact manufacturer for any modifications to the refrigeration, hydraulic or wiring diagram of the unit, as well as to its control logics
- contact manufacturer if it is necessary to perform very difficult disassembly and assembly operations
- use only original spare parts purchased directly from manufacturer or the official retailers of the companies on the recommended spare parts list
- contact manufacturer if it is necessary to handle the unit one year after its positioning on site or if you wish to dismantle it.

2 - Safety (continued)

2.7 Safety labels

Identification of the refrigerant - External door



Identification of the unit Outside, on the right-hand front column

| | |
|---------------------------------|-----|
| COD. PRODOTTO | (A) |
| DESCRIZIONE | (B) |
| CE | (C) |
| MODELLO | (D) |
| ANNO DI COSTRUZIONE | (E) |
| CARICA REFR. (kg) | (F) |
| ALTA PRESSIONE (bar) | (G) |
| BASSA PRESSIONE (bar) | (H) |
| ALTA POTENZA (kW) | (I) |
| COMPRESORI SU PIANO (n°) | (L) |
| COMPRESORI A FREDDO CARICO (n°) | (M) |
| POTENZA ASSORBITA (kW) | (N) |
| PIÙ ALTE POTENZA (kW) | (O) |
| ALTA POTENZA (kW) | (P) |
| ALTA POTENZA (kW) | (Q) |
| ALTA POTENZA (kW) | (R) |
| ALTA POTENZA (kW) | (S) |
| ALTA POTENZA (kW) | (T) |
| ALTA POTENZA (kW) | (U) |
| ALTA POTENZA (kW) | (V) |
| ALTA POTENZA (kW) | (W) |
| ALTA POTENZA (kW) | (X) |
| ALTA POTENZA (kW) | (Y) |
| ALTA POTENZA (kW) | (Z) |

Pump operation - Outside, on the right-hand front column

LAS BOMBAS MONTADAS EN ESTA UNIDAD NO PUEDEN TRABAJAR SIN AGUA.
 DIE PUMPEN DIESES GERÄTES DÜRFE NICHT OHNE WASSER BE TREIBEN WERDEN.
 THE PUMPS ON BOARD OF THIS UNIT CAN NOT WORK WITHOUT WATER.
 LES POMPES A BORD DE CETTE UNITE NE PEUVENT PAS FONCTIONNER SANS EAU.
 LE POMPE A BORDO DI QUESTA UNITÀ NON POSSONO FUNZIONARE SENZA ACQUA.

Circuit drain - Outside, on the right-hand front column



ATTENTION! Don't leave the unit with water inside hydraulic circuit during winter or when it is in stand by.
ATTENZIONE! Non lasciare l'unità con acqua nel circuito idraulico durante l'inverno o quando non è funzionante.
ATTENTION! Ne laissez pas l'unité avec de l'eau dans le circuit hydraulique pendant l'hiver ou quand elle ne travaille pas.
WARNUNG! Entfernen Sie das Wasser aus dem hydraulischen Kreislauf bei einem Defekt und im Winter.
¡ATENCIÓN! No deje el agua en el circuito hidráulico durante el invierno o cuando no está trabajando.

Instruction for the lifting

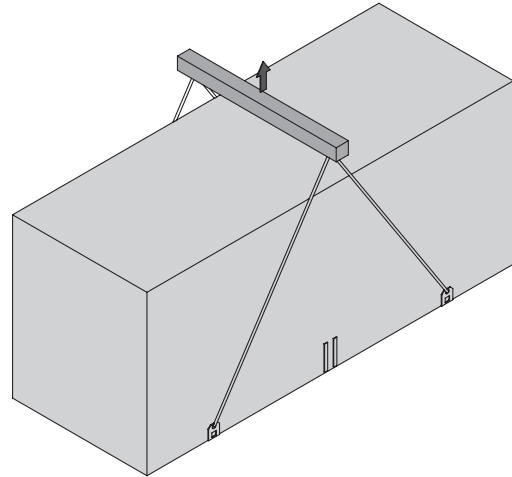

Sequence phase control on the electrical board

ATTENZIONE
 QUESTO COMPRESSORE RICHIEDE UN CORRETTO SENSO DI ROTAZIONE
 RISPETTARE LA CORRETTA SEQUENZA DELLE FASI
CAUTION
 THIS COMPRESSOR REQUIRES PROPER DIRECTION OF ROTATION
 CHECK PROPER ELECTRICAL PHASING
ACHTUNG
 KOMPRESSOREN BENÖTIGEN KORREKTES DREHFELD.
 ELEKTRISCHE ANSCHLÜSSE AUF DREHFELD ÜBERPRÜFEN
ATTENTION
 CES COMPRESSEURS NECESSITENT UN BON SENS DE ROTATION
 VÉRIFIER LE CABLAGE DES PHASES
ATENCIÓN
 ESTOS COMPRESORES DEBEN FUNCIONAR EN EL SENTIDO DE ROTACIÓN CORRECTO
 COMPROBAR EL CABLEADO DE LAS FASES

Gravity centre - Base

TENERE SU QUESTA LINEA
 GANCIO DI SOLLEVAMENTO

KEEP LIFT HOOK
 ON THIS LINE

Instruction for the lifting

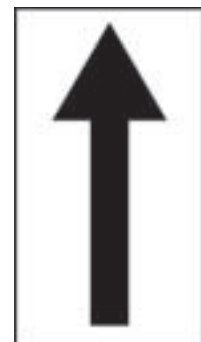

2 - Safety (continued)

Electrical warning Adjacent to the master switch

| | | |
|---|---|--|
|  | ATTENZIONE ! Prima di aprire togliere tensione | ATTENTION ! Enlever l'alimentation électrique avant d'ouvrir |
| | ACHTUNG ! Vor Öffnen des Gehäuses Hauptschalter betätigen | CAUTION ! Disconnect electrical supply before opening |

Start-up warning - Outside the door of the electrical board

ATTENZIONE

INSERIRE LE RESISTENZE DI RISCALDAMENTO OLIO ALMENO 12 ORE PRIMA DI OGNI AVVIAMENTO (SE PREVISTE) PRIMA DELLA MESSA IN TENSIONE ASSICURARSI CHE LE VITI DEI CIRCUITI ELETTRICI SIANO SERRATE COMPLETAMENTE

WARNING

ENERGIZE THE CRANCKCASE HEATER FOR AT LEAST 12 HOURS BEFORE EACH STARTING (IF FITTED) BEFORE TIGHTENING-UP, TO TIGHTEN ALL TERMINAL SCREWS ESPECIALLY THOSE IN MAIN CIRCUIT

WARNUNG

OLSUMPFFHEIZUNG (FALLS VORHANDEN) 12 STUNDEN VOR DEM START EINSCHALTEN VOR INBETRIEBNAHME ALLE SCHRAUBENVERBINDUNGEN NACHZIEHEN, BESONDERS DIE ELEKTRISCHEN ANSCHLUSSE

ATTENTION

ALIMENTER ELECTRIQUEMENT LA RESISTANCE DE CARTER AU MOINS 12 HEURES AVANT CHAQUE DEMARRAGE (SI MONTE SUR LE PRODUIT) AVANT DE DEMARRER LA MACHINE, VERIFIER LE SERRAGE DE TOUTES LES BORNES A VIS, SPECIALEMENT DANS LE BOITIER ELECTRIQUE

ATENCIÓN

ATENCIÓN ALIMENTAR ELÉCTRICAMENTE LA RESISTENCIA DE CARTER AL MENOS 12 HORAS ANTES DE CADA PUESTA EN MARCHA (SI ESTA EQUIPADA EN LA UNIDAD) ANTES DE LA PUESTA EN MARCHA, COMPROBAR QUE LOS BORNES ESTAN BIEN APRETADOS, ESPECIALMENTE EN EL CUADRO ELÉCTRICO

035B00057-000

MADE IN ITALY

Final Test Certificate - Inside the external door

| TEST NO. | DESCRIPTION OF TEST | RESULT |
|----------|--|--------|
| 1 | VERIFICA SERRAGGIO SCHEDE ELETTRICHE | |
| 2 | VERIFICA SERRAGGIO SCHEDE ELETTRICHE E CONNESSIONE SCHEDE MOTORI | |
| 3 | VERIFICA SERRAGGIO SCHEDE ELETTRICHE E CONNESSIONE SCHEDE MOTORI | |
| 4 | VERIFICA SERRAGGIO SCHEDE ELETTRICHE E CONNESSIONE SCHEDE MOTORI | |
| 5 | VERIFICA SERRAGGIO SCHEDE ELETTRICHE E CONNESSIONE SCHEDE MOTORI | |
| 6 | VERIFICA SERRAGGIO SCHEDE ELETTRICHE E CONNESSIONE SCHEDE MOTORI | |
| 7 | VERIFICA SERRAGGIO SCHEDE ELETTRICHE E CONNESSIONE SCHEDE MOTORI | |
| 8 | VERIFICA SERRAGGIO SCHEDE ELETTRICHE E CONNESSIONE SCHEDE MOTORI | |
| 9 | VERIFICA SERRAGGIO SCHEDE ELETTRICHE E CONNESSIONE SCHEDE MOTORI | |
| 10 | VERIFICA SERRAGGIO SCHEDE ELETTRICHE E CONNESSIONE SCHEDE MOTORI | |
| 11 | VERIFICA SERRAGGIO SCHEDE ELETTRICHE E CONNESSIONE SCHEDE MOTORI | |

Grounding connection on the electrical board, adjacent to the connection

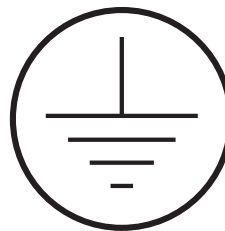

Read the instruction on the electrical board



Fan Danger

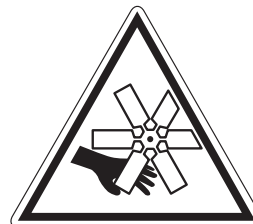

Fitting identification - Adjacent to fittings

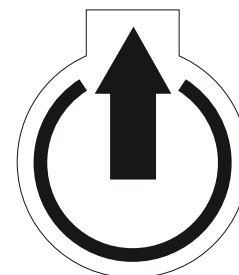
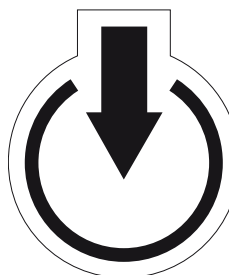

2 - Safety (continued)

2.8 Safety regulations

| REFRIGERANT DATA | SAFETY DATA: R410A |
|---|---|
| Toxicity | Low |
| Contact with skin | <p>If sprayed, the refrigerant is likely to cause frost burns. If absorbed by the skin, the danger is very limited; it may cause a slight irritation, and the liquid is degreasing. Unfreeze the affected skin with water. Remove the contaminated clothes with great care - in the presence of frost burns, the clothes may stick to the skin. Wash with plenty of warm water the affected skin.</p> <p>In the presence of symptoms such as irritation or blisters, obtain medical attention.</p> |
| Contact with eyes | <p>Vapours do not cause harmful effects. The spraying of refrigerant may cause frost burns. Wash immediately with a proper solution or with tap water for at least 10 minutes, and then obtain medical attention.</p> |
| Ingestion | <p>Very unlikely - should something happen, it will cause frost burns.</p> <p>Do not induce vomiting. Only if the patient is conscious, wash out mouth with water and give some 250 ml of water to drink. Then, obtain medical attention.</p> |
| Inhalation | <p>R410A: remarkable concentrations in the air may have an anaesthetic effect, up to fainting.</p> <p>The exposure to considerable amounts may cause irregular heartbeat, up to the sudden death of the patient. Very high concentrations may result in the risk of asphyxia, due to the reduction in the oxygen percentage in the atmosphere. Remove the patient to fresh air and keep warm and at rest.</p> <p>If necessary, give oxygen. In case of breathing difficulties or arrest, proceed with artificial respiration.</p> <p>In case of cardiac arrest, proceed with cardiac massage. Then, obtain medical attention.</p> |
| Recommendations | <p>Semiotics or support therapy is recommended. Cardiac sensitisation has been observed that, in the presence of circulating catecholamines such as adrenalin, may cause cardiac arrhythmia and accordingly, in case of exposure to high concentrations, cardiac arrest.</p> |
| Prolonged exposure | <p>R410A: a study on the effects of exposure to 50,000 ppm during the whole life of rats has identified the development of benign testicle tumour.</p> <p>This situation should therefore be negligible for personnel exposed to concentrations equal to or lower than professional levels.</p> |
| Professional levels | R410A: Recommended threshold: 1000 ppm v/v - 8 hours TWA. |
| Stability | R410A: Not specified |
| Conditions to avoid | Do not use in the presence of flames, burning surfaces and excess humidity. |
| Hazardous reactions | <p>May react with sodium, potassium, barium and other alkaline metals.</p> <p>Incompatible substances: magnesium and alloys with magnesium concentrations > 2%.</p> |
| Hazardous decomposition products | R410A: Halogen acids produced by thermal decomposition and hydrolysis. |

2 - Safety (continued)

2.8 Safety regulations (continued)

| REFRIGERANT DATA | SAFETY DATA: R410A |
|---|---|
| General precautions | Do not inhale concentrated vapours. Their concentration in the atmosphere should not exceed the minimum preset values and should be maintained below the professional threshold. Being more weighty than the air, the vapour concentrates on the bottom, in narrow areas. Therefore, the exhaust system must work at low level. |
| Respiratory system protection | If you are in doubt about the concentration in the atmosphere, it is recommended to wear a respirator approved by an accident-prevention Authority, of the independent or oxygen type. |
| Storage | Cylinders must be stored in a dry and fresh place, free from any fire hazard, far from direct sunlight or other sources of heat, radiators etc. Keep a temperature below 50 °C. |
| Protective clothing | Wear overalls, protective gloves and goggles or a mask. |
| Accidental release measures | It is important to wear protective clothing and a respirator. Stop the source of the leak, if you can do this without danger. Negligible leaks can be left evaporating under the sun, providing that the room is well ventilated. Considerable leaks: ventilate the room. Reduce the leak with sand, earth or other absorbing substances. Make sure that the liquid does not channelled into gutters, sewers or pits where the vapours are likely to create a stuffy atmosphere. |
| Disposal | The best method is recovery and recycling. If this method is not practicable, dispose according to an approved procedure, that shall ensure the absorption and neutralization of acids and toxic agents. |
| Fire fighting information | R410A: Not flammable in the atmosphere. |
| Cylinders | The cylinders, if exposed to fire, shall be cooled by water jets; otherwise, if heated, they may explode. |
| Protective fire fighting equipment | In case of fire, wear an independent respirator and protective clothing. |

2 - Safety (continued)

2.8 Safety regulations (continued)

| LUBRICANT OIL DATA | SAFETY DATA: POE/PVE OIL |
|---|---|
| Classification | Not harmful. |
| Contact with skin | May cause slight irritation. Does not require first aid measures. It is recommended to follow usual personal hygiene measures, including washing the exposed skin with soap and water several times a day. It is also recommended to wash your overalls at least once a week. |
| Contact with eyes | Wash thoroughly with a suitable solution or tap water. |
| Ingestion | Seek medical advice immediately. |
| Inhalation | Seek medical advice immediately. |
| Conditions to avoid | Strong oxidising substances, caustic or acid solutions, excess heat. May corrode some types of paint or rubber. |
| Protection of the respiratory system | Use in well ventilated rooms. |
| Protective clothing | Always wear protective goggles or a mask. Wearing protective gloves is not mandatory, but is recommended in case of prolonged exposure to refrigerant oil. |
| Accidental release measures | It is important to wear protective clothing and, especially, goggles. Stop the source of the leak. Reduce the leak with absorbing substances (sand, sawdust or any other absorbing material available on the market). |
| Disposal | The refrigerant oil and its waste will be disposed of in an approved incinerator, in conformity with the provisions and the local regulations applicable to oil waste. |
| Fire fighting information | In the presence of hot liquid or flames, use dry powder, carbon dioxide or foam. If the leak is not burning, use a water jet to remove any vapours and to protect the personnel responsible for stopping the leak. |
| Cylinders | The cylinders exposed to a fire will be cooled with water jets in case of fire. |
| Fire fighting protective equipment | In case of fire, wear an independent respirator. |

3 - Transport, Lifting and Positioning

Refrigerators are supplied assembled (apart from standard antivibrating rubber supports, that will be installed on site). The equipment are full of refrigerant and oil, in the quantity required for a proper operation.

3.1 Inspection

When the unit is delivered, it is recommended to check it carefully and to identify any damage occurred during transportation. The goods are shipped ex-factory, at the buyer's risk. Check that the delivery includes all the components listed in the order.

In case of damage, note it down on the carrier's delivery note and issue a claim according to the instructions provided in the delivery note.

In the presence of any serious damage, that does not affect the surface only, it is recommended to inform manufacturer immediately.

Please note that manufacturer may not be held liable for any damage to the equipment during transportation, even though the carrier has been appointed by the factory.

3.2 Lifting

The unit must be lifted by using the hooks inserted into the relevant eyebolts (see the figure).

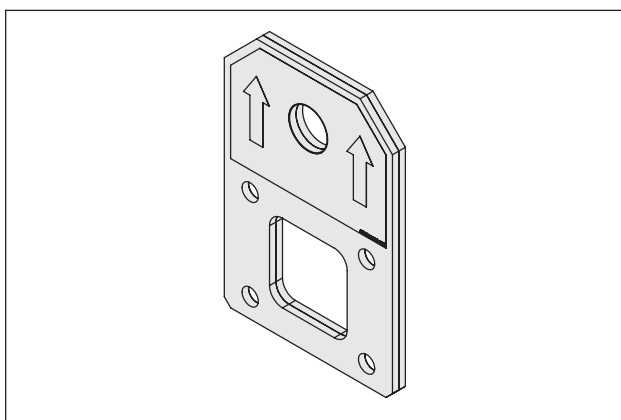

It is recommended to use a spacer to prevent cables from damaging the unit (see the figure).

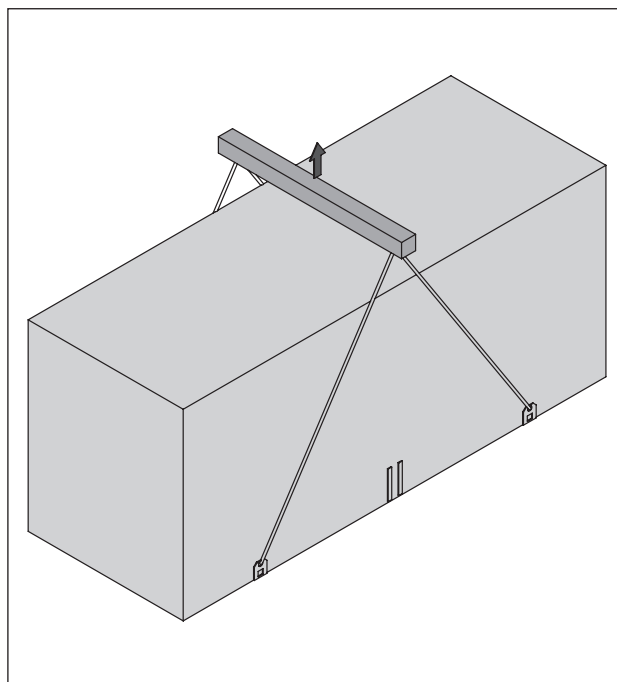

Before positioning the unit, make sure that the place of installation is appropriate and sturdy enough to hold the weight and to withstand the stress caused by the operation of the whole assembly.



Do not displace the unit on rollers, and do not lift it with a lift truck.

Unit must be lifted carefully.

To lift unit slowly and regularly.

To lift and displace the unit:

- Insert and secure eyebolts into the holes marked on the frame.
- Insert spacer between cables.
- Place the spacer in line with the center of gravity of the unit.
- The cables must be long enough to form, if tensioned, an angle of at least 45° with respect to the horizontal plane.



For lifting operations, use only tools and material fit for this purpose, in accordance with accident-prevention regulations.

3 - Transport, Lifting and Positioning (continued)



During the lifting and handling of the unit, be careful not to damage the finned pack of the coils positioned on the sides of the unit.

The sides of the unit must be protected by cardboard or plywood sheets.



It is recommended not to remove the protective plastic envelope, that should prevent scraps from penetrating into the appliance and any damage to the surfaces, until the unit is ready for operation.



The lifting eyebolts protrude from the base of the unit; it is therefore recommended to remove them once the unit has been lifted and positioned, if in your opinion they are likely to become a source of hazard and injury.

The eyebolts must be mounted on the unit whenever it shall be displaced and then lifted again.

3.3 Anchoring

It is not essential to secure the unit to the foundations, unless in areas where there is a serious risk of earthquake, or if the appliance is installed on the top of a steel frame.

3.4 Storage

When the unit is to be stored before installation, adopt a few precautions to prevent any damage or risk of corrosion or wear:

- plug or seal every single opening, such as water fittings
- do not store the appliance in a room where the temperature exceeds 50 °C for the units using R410A and, if possible, do not expose to direct sunlight
- minimum storage temperature is -25 °C
- it is recommended to store the unit in a roof where traffic is minimized, to prevent the risk of accidental damage
- the unit must not be washed with a steam jet
- take away and leave to the site manager all the keys providing access to the control board

Finally, it is recommended to carry out visual inspections at regular intervals.

4 - Installation

4.1 Positioning of the unit



Before installing the unit, make sure that the structure of the building and/or the supporting surface can withstand the weight of the appliance. The weights of the units are listed in Chapter 8 of this manual.

These units have been designed for outdoor installation on a solid surface. Standard accessories include antivibrating rubber supports, that must be positioned under the base.

When the unit is to be installed on the ground, it is necessary to provide a concrete base, to ensure a uniform distribution of the weights.

As a general rule, no special sub-bases are required. However, if the unit is to be installed on the top of inhabited rooms, it is advisable to rest it on spring shock absorbers (optional), that will minimise the transmission of any vibration to the structures.

To choose the place of installation of the unit, bear in mind that:

- the longitudinal axis of the unit must be parallel to the direction of prevailing winds, so as to ensure a uniform distribution of the air on finned exchangers
- the unit must not be installed near boilers' vent pipes
- the unit must not be installed leeward with respect to sources of air contaminated by greases, such as, for example, the outlets to kitchen exhaust hoods into the atmosphere. Otherwise, the grease is likely to deposit on the fins of the refrigerant /air exchangers, and would fix every type of atmospheric impurity, resulting in the quick clogging of the exchangers
- the unit must not be installed in areas subject to considerable snow falling
- the unit must not be installed in areas subject to flooding, under gutters etc.
- the unit must not be installed in air shafts, narrow courts or other small places, where the noise may be reflected by the walls or the air ejected by fans may short-circuit itself on refrigerant/air heat exchangers or condenser
- the place of installation must be have all the necessary spaces for air circulation and maintenance operations (see Chapter 8).

4.2 Spring Isolator Installation

- Prepare the base, that must be flat and plane.
- Lift the appliance and insert shock absorbers as follows:

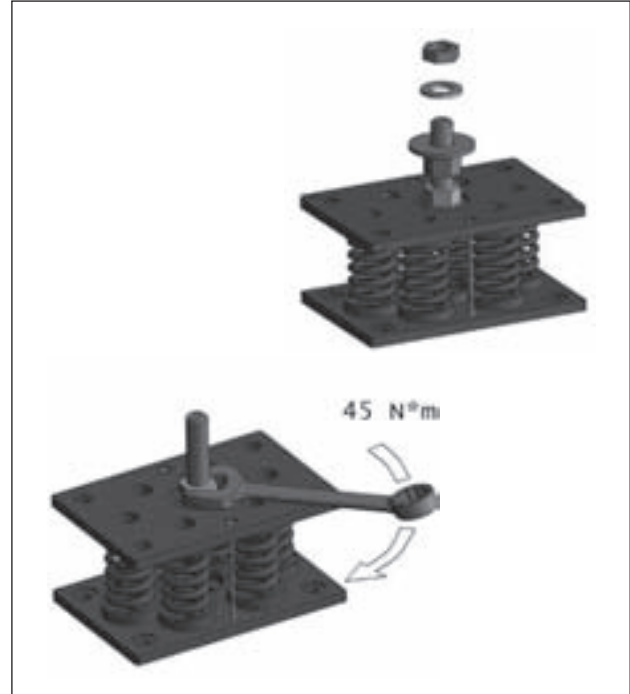

- 1) Proceed to assemble the jack components. Fit the jack in the threaded housing on the upper plate of the antivibration mount.

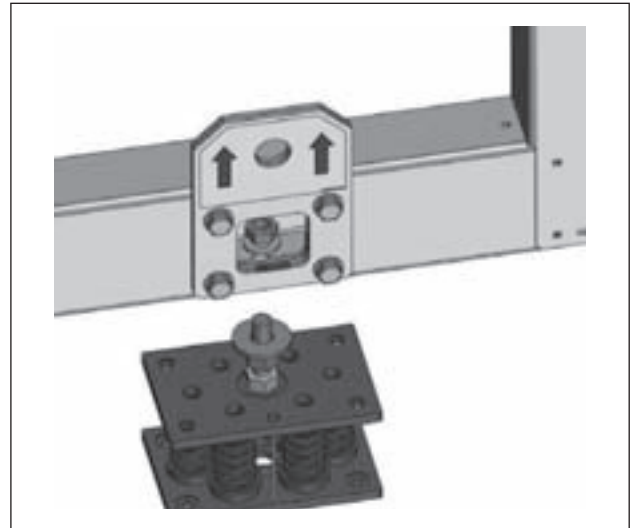

- 2) Fit the jack mounted on the antivibration mount in the hole in the machine base.

4 - Installation (continued)

4.3 External Water Circuit

The flow switch and the filter water, although not included in the supply, must always be fitted such as plant components. Their installation is mandatory for warranty.



The external water circuit shall guarantee a constant water flow rate through the circulating refrigerant/water heat exchanger (evaporator) under steady operating conditions and in case of a load variation.

The circuit shall be composed by the following elements:

- A circulation pump which can ensure the necessary flow rate and head.
- The total content of the primary water circuit shall never be lower than 3 l/kW in terms of refrigerating capacity. If the total water volume in the primary circuit should be unable to reach such a value, an additional heat-insulated storage tank should be installed. This tank is intended to avoid any repetitive start of the compressor.
- A membrane expansion tank complete with a safety valve and a drain which shall be visible.



The expansion tank shall be dimensioned in such a way that it can absorb a 2% expansion of the total volume of the water in the plant (exchanger, pipelines, uses and storage tank, if available).

The expansion tank shall never be insulated when the circulating fluid is not flowing through it.

A water flow switch is mounted as a standard. It will stop the unit whenever a flow rate problem occurs.

In addition:

- Install on/off valves (accessory) on the lines at the inlet and outlet of the manifolds of the exchangers (evaporator).
- Arrange a by-pass complete with an on/off valve between the manifolds of the heat exchangers.
- Arrange air vent valves at the high points of the water lines.
- Arrange drain points complete with plugs, cocks, etc. in the proximity of the low points of the water lines.
- Insulate the water lines to prevent the heat from blowing back into the unit.

4 - Installation (continued)

Hydraulic Circuit Diagram - Basic Unit

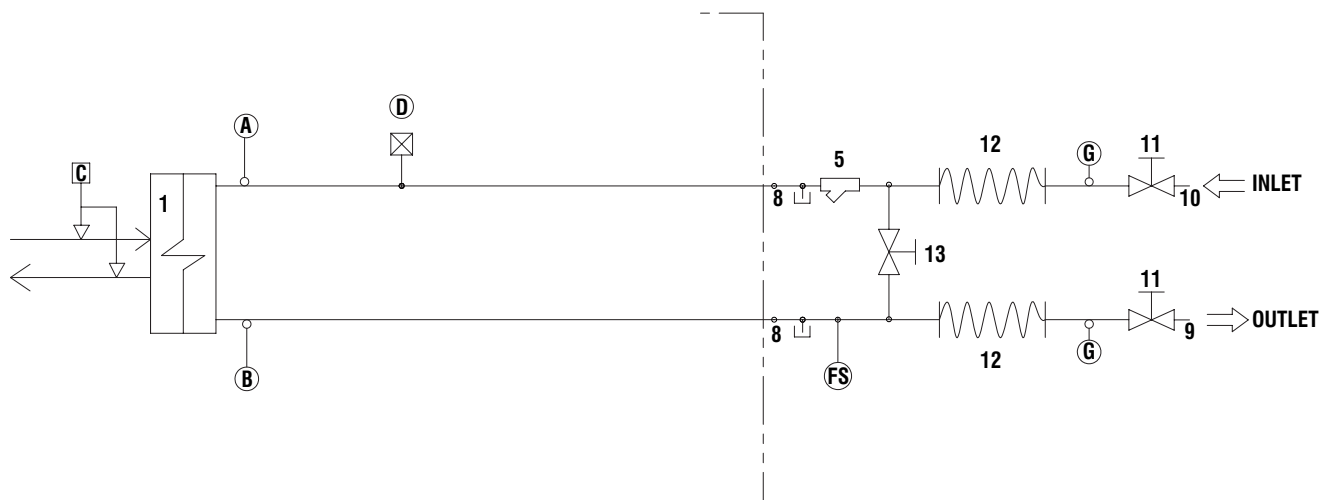

| COMPONENTS | |
|------------|-------------------------|
| 1 | Plate heat exchanger |
| 2 | Pump |
| 3 | Draining valve |
| 4 | Water buffer tank |
| 5 | Water filter |
| 6 | Non-return valve |
| 7 | Pressure expansion tank |
| 8 | Pressure point/drainage |
| 9 | Water outlet |
| 10 | Water inlet |
| 11 | Globe valve |
| 12 | Flexible pipes |
| 13 | By pass valve |

| SAFETY/CONTROL DEVICES | |
|------------------------|------------------------------------|
| A | Inlet water temperature sensor |
| B | Outlet water temperature sensor |
| C | Water differential pressure switch |
| D | Vent valve |
| E | Water safety valve.....(6Bar) |
| FS | Flow switch |
| G | Thermometer |
| ---- | Unit side |
| O | Probes |

4 - Installation (continued)

Hydraulic Circuit Diagram - 1P Unit

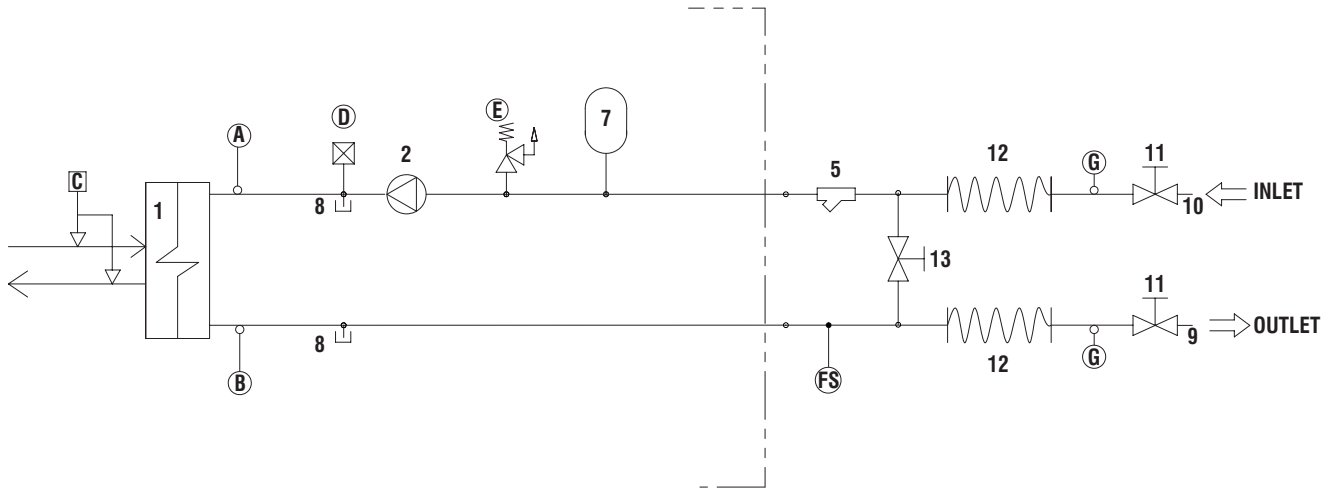

| COMPONENTS | |
|------------|-------------------------|
| 1 | Plate heat exchanger |
| 2 | Pump |
| 3 | Draining valve |
| 4 | Water buffer tank |
| 5 | Water filter |
| 6 | Non-return valve |
| 7 | Pressure expansion tank |
| 8 | Pressure point/drainage |
| 9 | Water outlet |
| 10 | Water inlet |
| 11 | Globe valve |
| 12 | Flexible pipes |
| 13 | By pass valve |

| SAFETY/CONTROL DEVICES | |
|------------------------|------------------------------------|
| A | Inlet water temperature sensor |
| B | Outlet water temperature sensor |
| C | Water differential pressure switch |
| D | Vent valve |
| E | Water safety valve.....(6Bar) |
| FS | Flow switch |
| G | Thermometer |
| ---- | Unit side |
| O | Probes |

4 - Installation (continued)

Hydraulic Circuit Diagram - 2P Unit

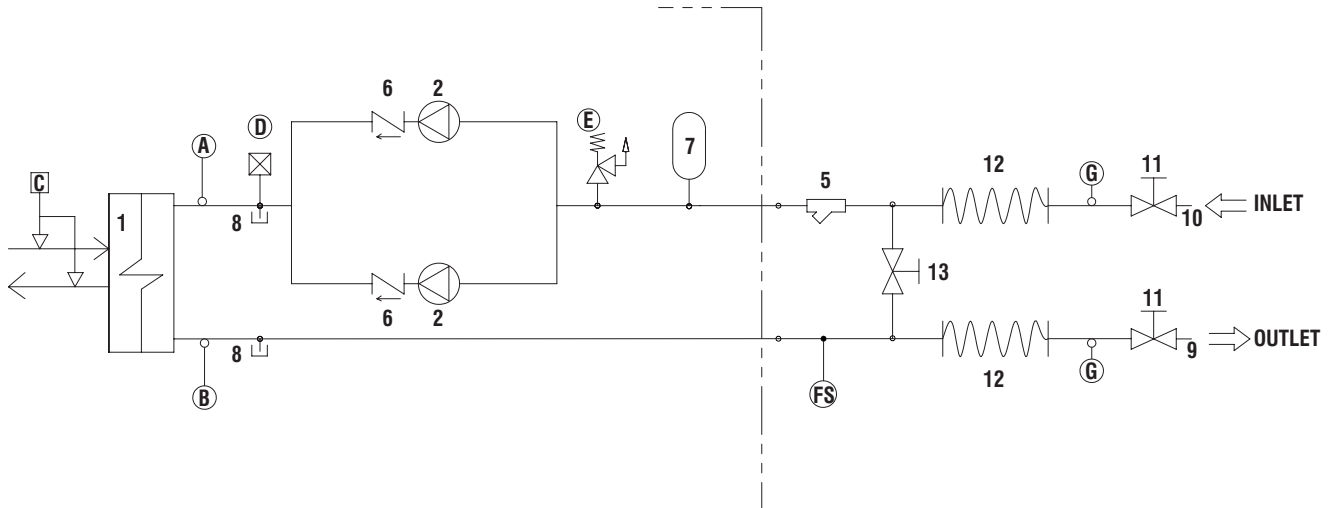

| COMPONENTS | |
|------------|-------------------------|
| 1 | Plate heat exchanger |
| 2 | Pump |
| 3 | Draining valve |
| 4 | Water buffer tank |
| 5 | Water filter |
| 6 | Non-return valve |
| 7 | Pressure expansion tank |
| 8 | Pressure point/drainage |
| 9 | Water outlet |
| 10 | Water inlet |
| 11 | Globe valve |
| 12 | Flexible pipes |
| 13 | By pass valve |

| SAFETY/CONTROL DEVICES | |
|------------------------|------------------------------------|
| A | Inlet water temperature sensor |
| B | Outlet water temperature sensor |
| C | Water differential pressure switch |
| D | Vent valve |
| E | Water safety valve.....(6Bar) |
| FS | Flow switch |
| G | Thermometer |
| ---- | Unit side |
| ○ | Probes |

4 - Installation (continued)

Hydraulic Circuit Diagram - 1P+T Unit

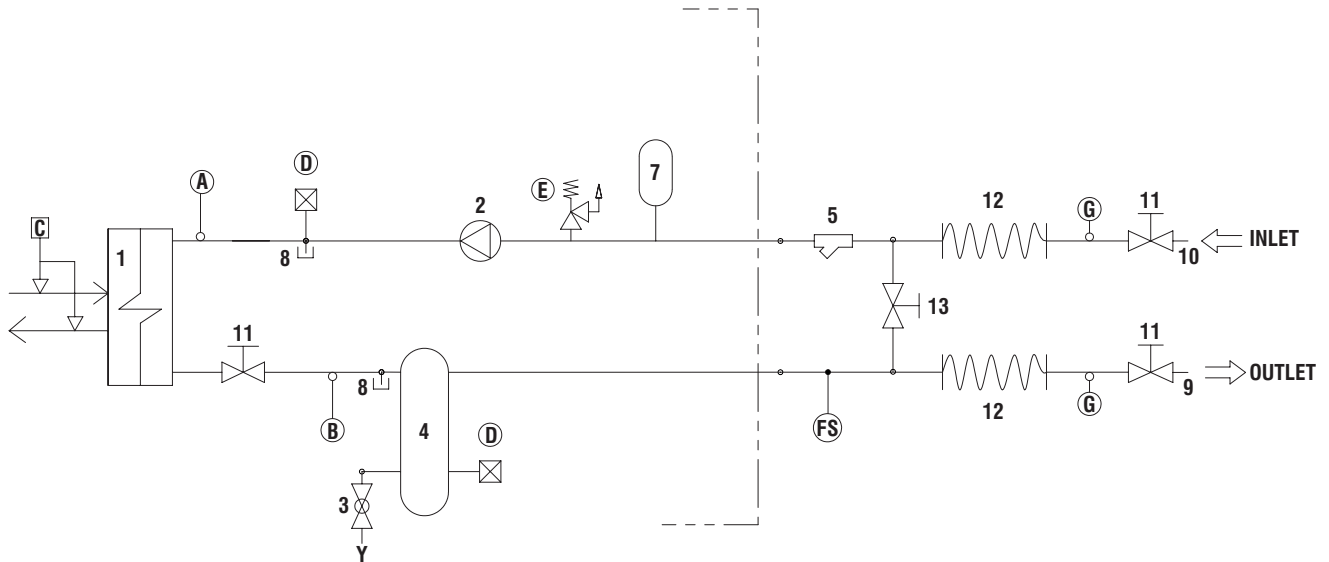

| COMPONENTS | |
|------------|-------------------------|
| 1 | Plate heat exchanger |
| 2 | Pump |
| 3 | Draining valve |
| 4 | Water buffer tank |
| 5 | Water filter |
| 6 | Non-return valve |
| 7 | Pressure expansion tank |
| 8 | Pressure point/drainage |
| 9 | Water outlet |
| 10 | Water inlet |
| 11 | Globe valve |
| 12 | Flexible pipes |
| 13 | By pass valve |

| SAFETY/CONTROL DEVICES | |
|------------------------|------------------------------------|
| A | Inlet water temperature sensor |
| B | Outlet water temperature sensor |
| C | Water differential pressure switch |
| D | Vent valve |
| E | Water safety valve.....(6Bar) |
| FS | Flow switch |
| G | Thermometer |
| ---- | Unit side |
| O | Probes |

4 - Installation (continued)

Hydraulic Circuit Diagram - 2P+T Unit

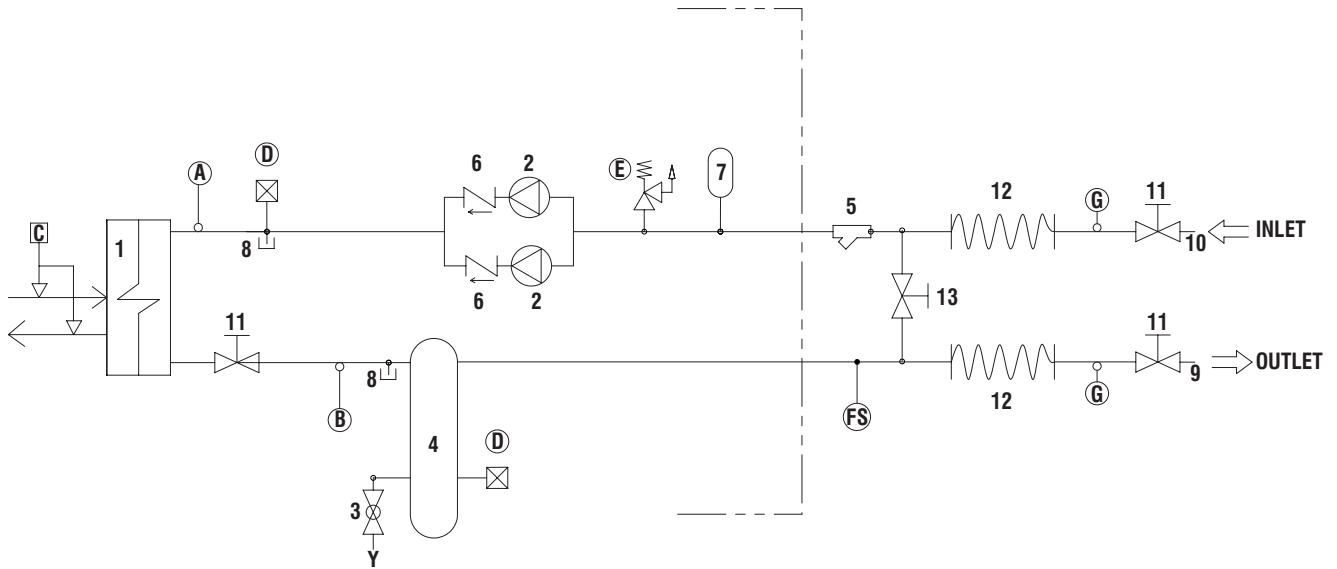

| COMPONENTS | |
|------------|-------------------------|
| 1 | Plate heat exchanger |
| 2 | Pump |
| 3 | Draining valve |
| 4 | Water buffer tank |
| 5 | Water filter |
| 6 | Non-return valve |
| 7 | Pressure expansion tank |
| 8 | Pressure point/drainage |
| 9 | Water outlet |
| 10 | Water inlet |
| 11 | Globe valve |
| 12 | Flexible pipes |
| 13 | By pass valve |

| SAFETY/CONTROL DEVICES | |
|------------------------|------------------------------------|
| A | Inlet water temperature sensor |
| B | Outlet water temperature sensor |
| C | Water differential pressure switch |
| D | Vent valve |
| E | Water safety valve.....(6Bar) |
| FS | Flow switch |
| G | Thermometer |
| ---- | Unit side |
| O | Probes |

4 - Installation (continued)

4.4 Water connections



The attachments at the water inlet and outlet shall be connected in compliance with the instructions which can be found on the labels in the proximity of the attachments.

Connect the water lines of the plants with the attachments of the unit whose diameters and positions are shown by Chapter 8.

4.5 Defrost water drainage (only for Heat Pump units)

When heat pump units work in heating mode, during defrosting cycles, they may discharge water from the base. This is why the units should be installed at least 200 mm above the floor level, so as to allow the free drainage of waste water, without the risk of producing ice banks.

The heat pump units must be installed in positions where the defrosting water cannot create any damage.

4.6 Power supply



Before carrying out any operations on the electrical system, make sure that the unit is deenergised.



It is important that the appliance is grounded.



The company in charge of the installation shall conform to the standards applicable to outdoor electrical connections.

The manufacturer may not be held liable for any damage and/or injury caused by failure to comply with these precautions.

The unit conforms to EN 60204-1.

The following connections shall be provided:

- A 3-phase and grounding connection for the power supply circuit.
- The electrical distribution system shall meet the power absorbed by the appliance.
- The disconnecting and magnetothermal switches must be sized to control the starting current of the unit.
- The power supply lines and the insulation devices must be designed in such a way that every line independent.
- It is recommended to install differential switches, to prevent any damage caused by phase drops.
- The fans and compressors are supplied through contactors controlled from the control panel.
- Each motor is provided with an internal safety thermal device and external fuses.
- The power supply cables must be inserted into dedicated openings on the front of the unit, and they will enter the electrical board through holes drilled on the bottom of the board.

4 - Installation (continued)

4.7 Electrical connections

The unit must be installed on site according to the Machinery Directive (2006/42/EC), the Low Voltage Directive (2006/95/EC), the Electromagnetic Interference Directive (2004/108/EC) and the usual procedures and standards applicable in the place of installation.

The unit must not be operated if its installation has not been carried out according to the instructions provided in this manual.

The power supply lines must consist of insulated copper conductors, dimensioned for the maximum absorbed current.

Connection to terminals must be performed according to the diagram of connections (User's Terminal Box) provided in this manual and according to the wiring diagram which accompanies the unit.



Before connecting the power supply lines, check that the available voltage value does not exceed the range specified in the Electric Data (Chapter 8).

For 3-phase systems, check also that the unbalance between the phases does not exceed 2%. To perform this check, measure the differences between the voltage of each phase couple and their mean value during operation.

The maximum % value of these differences (unbalance) must not exceed 2% of the mean voltage.

If the unbalance is unacceptable, contact the Energy Distributor to solve this problem.



Supplying the unit through a line whose unbalance exceeds the permissible value will automatically void the warranty.

4.8 Connecting plate-type evaporator temperature sensors

Only Cooling and Heat Pump units are provided with fittings for hydraulic connections between heat exchangers and plant.

Each fittings is complete with sensor well to fasten temperature sensor (BT-IN and BT-OUT). Fittings are supplied separate and must be mounted during the installation of the unit, as explained in the instruction below.

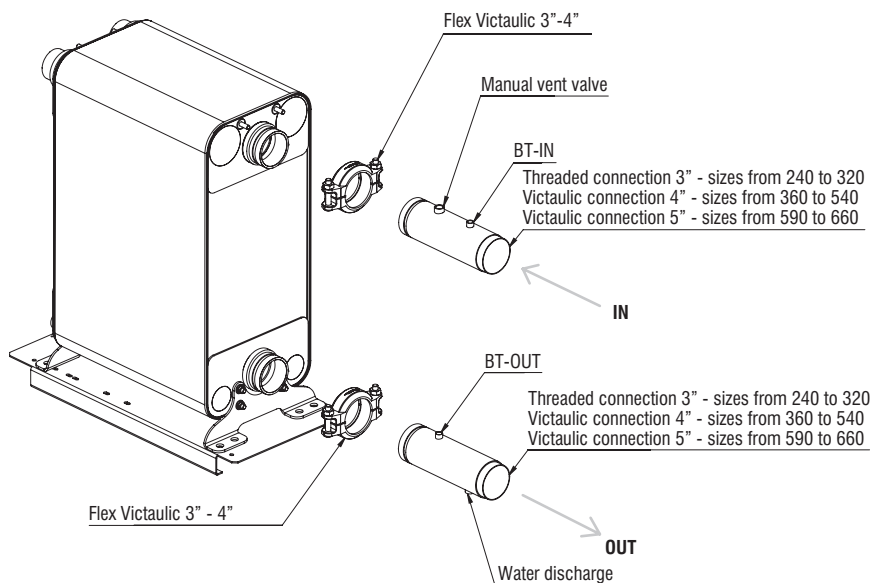

4 - Installation (continued)

Electrical Connections

QG - Y1

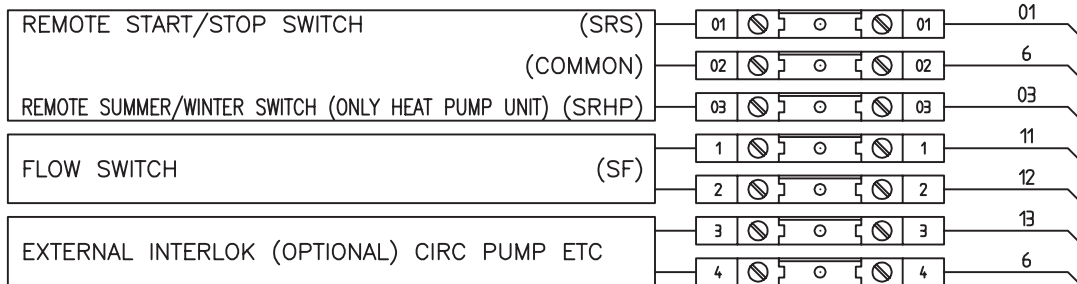

QG - Y2

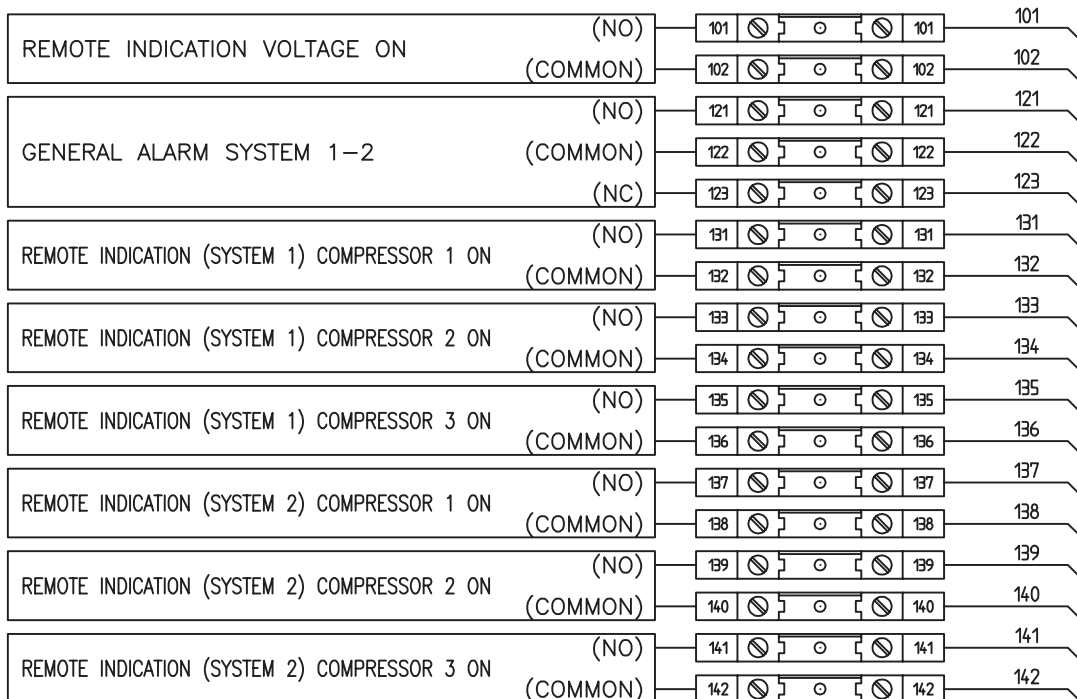

QG - Y3

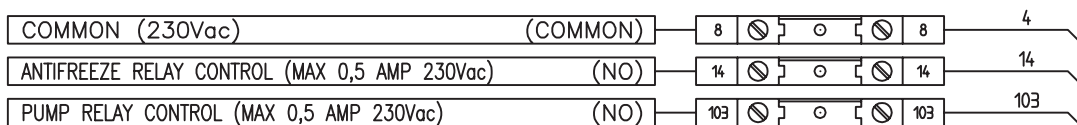

Note: For the other version refer to documentation attached to machine.

5 - Start-Up



The unit must be started for the first time by personnel suitably trained by one Authorised Service Centre. Failure to meet this requirement will immediately void the warranty.



The operations carried out by authorised personnel are limited to the start-up of the unit, and do not include any other operation on the plant, such as, for example, electrical and hydraulic connections etc.

All the other operations before start-up, including oil pre-heating for at least 12 hours, must be performed by the Installer.

5.1 Preliminary check

The checks listed below shall be performed before starting the unit and before the arrival of the personnel authorised.

- Check the section of power supply and grounding cables; make sure that terminals are tightened and check the correct operation of contactors, with the main switch open.
- Check that any voltage and phase variation in the power supply does not exceed the prefixed thresholds.
- Connect the contacts of the flow switch and the thermal relay of the pump and of the other devices (if any), to terminals 1-2 and 3-4, respectively.
- Check that the components of the external water circuit (pump, user equipment, filters, power supply tank and reservoir, if any) have been installed properly, and according to the manufacturer's instructions.
- Check the filling of the hydraulic circuits, and make sure that the fluid circulation is correct, without any trace of leaks and air bubbles. If you use ethylene glycol as antifreeze, check that its percentage is correct (do not exceed 35% glycol percentage).
- Check that the direction of rotation of the pumps is correct, and that fluids have been circulating for at least 12 hours for both pumps. Then, clean the filters on the suction side of the pumps.
- Adjust the liquid distribution network in such a way that the flow rate is within the specified range.
- Check that the water quality is up to the specifications.
- Check that oil heaters, if any, have been turned on at least 12 hours before.

5.2 Start-up

Start-up sequence:

- Turn on the Main switch (at least 12 hours before).
- Check that the oil in the compressor has reached the requested temperature (the minimum temperature outside the pan must be approx. 40°C) and that the auxiliary control circuit is energised.
- Check the operation of all the external equipment, and make sure that the control devices of the plant are properly calibrated.

- Start the pump and check that the water flow is correct.
- Set the desired fluid temperature on the control board.
- Start the appliance (see Chapter 6).
- Check the correct direction of rotation of compressors. Scroll compressors cannot compress the refrigerant when they rotate in the opposite direction. To make sure that they are rotating in the correct direction, simply check that, just after the start-up of the compressor, the pressure drops on the LP side and rises on the HP side. Furthermore, if a scroll compressor rotate in the opposite direction, there is a considerable rise in the sound level of the unit, as well as in a dramatic reduction of current absorption compared to normal values. In case of wrong rotation, the scroll compressor can be definitely damaged. Phase monitor is assembled in the unit as a standard to prevent wrong compressors rotation.
- After about 15 minutes of operation check that there are no bubbles, through the sight glass on the liquid line.



The presence of bubbles may indicate that a part of the refrigerant charge has been released in one or more points. It is important to remove these leaks before proceeding.

- Repeat the start-up procedure after removing the leaks.

5.3 Checking the operation

Check the following:

- The temperature of the water entering the evaporator.
- The temperature of the water leaving the evaporator.
- The level of the water flow rate in the evaporator, if possible.
- The current absorption upon the start of the compressor and in case of stabilised operation.
- The fan's current absorption.

Check that the condensing and evaporation temperatures, during operation at high and low pressure detected by the pressure gauges of the refrigerant, are within the following range:

(On the units not provided with HP/LP pressure gauges for the refrigerant, connect a pressure gauge to the Schrader valves on the refrigeration circuit).

| | |
|---------|---|
| HP side | Approx. 11 to 15 °C above the temperature of the air entering the condenser, for R410A units. |
| LP side | Approx. 2 to 4 °C below the temperature of the leaving chilled water, for R410A units. |

5.4 Delivery to the customer

- Train the user according to the instructions provided in Section 6.

6 - Control

6 General information

Introduction

This document contains the information and the operating instructions for units equipped with 3/4/5/6 compressors.

This information is for the after-sales service and the production operators, for the end-of-line testing.

Main characteristics

- Microprocessor control
- User-friendly keyboard
- Proportional and integral control of the return water temperature (RWT)
- Hysteresis control of the leaving water temperature (LWT)
- Access code to enter the Manufacturer's Level
- Access code to enter the Assistance Level
- Alarm and LED
- Backlighted LCD
- Pump-Down logic
- Rotation of the compressor operation
- Oil return function
- Night mode (or Low Noise) control
- Counting of the pump/compressors' hours of operation
- Display of discharge and suction pressure values
- Display of temperature sensor
- History of stored alarms (option)
- Built-in serial Communication RS485 Card; to connect the "Chiller Control" to a BMS network

The following accessories can be also connected:

- Remote Display Terminal
- Wire Remote Control.

6.1 The "CHILLER CONTROL" system

The machines are provided with a microprocessor card which is fully programmed by default for the control of a unit with 2 circuits, 1/2/3 compressors per circuit, a high and a low pressure transducer per circuit.

The control system consists of:

Keyboard & Display Terminal

General information

The figure shows the terminal with the front door open.

It is provided with a LCD 8 lines x 22 columns, keyboard and microprocessor-controlled LED's, so as to allow the programming of the control parameters (setpoint, differential bands, alarm thresholds) and themain operations to be carried out by the user.



Terminal & Key Board description







The terminal makes it possible to carry out the following operations:

- the initial configuration of the machine
- the change of all the main operating parameters
- the display of the detected alarms
- the display of all the measured quantities

The terminal and the card are connected by a 6-way phone cable.

The connection of the terminal to the basic card is not essential for the normal operation of the controller.

6 - Control (continued)

| | |
|--|--|
|  | Esc key: allows you to move from one mask to another. |
|  | Alarm key: used to display the alarms, to reset them in manual. Press it one to display the mask of the activated alarm, press it again to reset the alarm signal. |
|  | Prg+Esc keys: Pressing these keys at the same time, allows you to turn the unit on/off. |
|  | Up-down keys: allows you to set the control parameters' values and to move from one mask to another (not backlighted). |
|  | Enter key: used to move the cursor inside the masks and to save the values of the set parameters. |
|  | Alarm + Enter keys: press these keys at the same time to enter the "historical alarm" after 1' come back at status machine menu. |

6.2 Display



The display is an LCD 4 lines x 20 columns. The quantities and the information about the operation of the unit are alternated in the form of subsequent screens, named.

6.3 Keyboard

Arrows key - Up/Down/Enter

If the cursor is in the top left-hand corner (Home), press the UP/DOWN keys to access the subsequent masks associated to the selected branch. If a mask includes some value setting fields and you press the ENTER key, the cursor will reach these fields.

Once you have reached the quantity setting field, you can modify any value (within the expected limits) by pressing the UP/DOWN keys.

After you have selected the desired value, press the ENTER key again to store it.

6 - Control (continued)

Alarms

| Alarm code | Description | Notes |
|------------|---|-------|
| 1 | Main board - EPROM Failure | |
| 2 | Main board - Clock card Failure | |
| 3 | Main board - External air temperature sensor fault | |
| 4 | Main board - Return Water temperature sensor fault | |
| 5 | Main board - Leaving Water temperature sys 1 sensor fault | |
| 6 | Main board - Leaving Water temperature sys 2 sensor fault | |
| 7 | Main board - Low pressure sys 1 sensor fault | |
| 8 | Main board - Low pressure sys 2 sensor fault | |
| 9 | Main board - High pressure sys 1 sensor fault | |
| 10 | Main board - High pressure sys 2 sensor fault | |
| 11 | Main board - Discharge temperature sys 1 sensor fault | |
| 12 | Main board - Discharge temperature sys 2 sensor fault | |
| 13 | Main board - Coil Temperature sys 1 sensor fault | |
| 14 | Main board - Coil Temperature sys 2 sensor fault | |
| 15 | Flow switch / Interlock / Serious alarm (SQZ) | |
| 16 | Serious alarm (SQZ) | |
| 17 | Flow switch / Interlock | |
| 20 | High pressure switch Sys 1 | |
| 21 | High pressure switch Sys 2 | |
| 22 | Low pressure Sys 1 switch manual reset | |
| 23 | Low pressure Sys 2 switch manual reset | |
| 24 | Thermal protection compressor 1 Sys 1 manual reset | |
| 25 | Thermal protection compressor 2 Sys 1 manual reset | |
| 26 | Thermal protection compressor 3 Sys 1 manual reset | |
| 27 | Thermal protection compressor 1 Sys 2 manual reset | |
| 28 | Thermal protection compressor 2 Sys 2 manual reset | |
| 29 | Thermal protection compressor 3 Sys 2 manual reset | |
| 30 | Fan Thermal protection manual reset | |
| 31 | Fan Thermal protection Group 1 Sys 1 manual reset | |
| 32 | Fan Thermal protection Group 2 Sys 1 manual reset | |
| 33 | Fan Thermal protection Group 1 Sys 2 manual reset | |
| 34 | Fan Thermal protection Group 2 Sys 2 manual reset | |
| 35 | Low refrigerant cutout Sys 1 manual reset | |
| 36 | Low refrigerant cutout Sys 2 manual reset | |
| 37 | Low pressure alarm Sys 1 manual reset | |
| 38 | Low pressure alarm Sys 2 manual reset | |
| 39 | Out of envelope Sys 1 manual reset | |
| 40 | Out of envelope Sys 2 manual reset | |
| 41 | High pressure Sys 1 manual reset | |
| 42 | High pressure Sys 2 manual reset | |
| 43 | High limit discharge temperature Sys1 manual reset | |
| 44 | High limit discharge temperature Sys2 manual reset | |
| 45 | ΔT Water Too High Sys1 | |
| 46 | ΔT Water Too High Sys2 | |
| 47 | Wrong Water Trend Sys1 | |
| 48 | Wrong Water Trend Sys2 | |
| 49 | Antifreeze alarm Sys 1 manual reset | |
| 50 | Antifreeze alarm Sys 2 manual reset | |
| 51 | Antifreeze alarm Recovery manual reset | |
| 52 | Pump maintenance | |
| 53 | Compressor 1 Sys 1 maintenance | |
| 54 | Compressor 2 Sys 1 maintenance | |
| 56 | Compressor 1 Sys 2 maintenance | |
| 57 | Compressor 2 Sys 2 maintenance | |
| 59 | Driver 1 LAN disconnected | |
| 60 | Driver 2 LAN disconnected | |

6 - Control (continued)

| Alarm code | Description | Notes |
|------------|--|-------|
| 61 | EPROM Error Driver 1 | |
| 62 | EPROM Error Driver 2 | |
| 63 | Driver 1 S1 Sensor fault | |
| 64 | Driver 1 S3 Sensor fault | |
| 65 | Driver 1 S2 Sensor fault | |
| 66 | Driver 1 S4 Sensor fault | |
| 67 | Driver 2 S1 Sensor fault | |
| 68 | Driver 2 S3 Sensor fault | |
| 69 | EEV motor Error (Check wiring) Sys 1 | |
| 70 | EEV motor Error (Check wiring) Sys 2 | |
| 71 | Driver 1 Battery alarm | |
| 72 | Driver 2 Battery alarm | |
| 73 | Autotune alarm Sys 1 | |
| 74 | Autotune alarm Sys 2 | |
| 75 | Low suction alarm Sys 1 | |
| 76 | Low suction alarm Sys 2 | |
| 77 | Driver 1 Regulation Alarm | |
| 78 | Driver 2 Regulation Alarm | |
| 79 | Expansion board 1 OFF LINE | |
| 80 | Expansion board 2 OFF LINE | |
| 81 | Expansion board 1 - sensor 1 fault | |
| 82 | Expansion board 1 - sensor 2 fault | |
| 83 | Expansion board 1 - sensor 3 fault | |
| 84 | Expansion board 1 - sensor 4 fault | |
| 85 | Safety Extra Heater | |
| 86 | Recovery Flow switch | |
| 122 | Low pressure Sys 1 switch auto reset | |
| 123 | Low pressure Sys 2 switch auto reset | |
| 124 | Thermal protection compressor 1 Sys 1 auto reset | |
| 125 | Thermal protection compressor 2 Sys 1 auto reset | |
| 126 | Thermal protection compressor 3 Sys 1 auto reset | |
| 127 | Thermal protection compressor 1 Sys 2 auto reset | |
| 128 | Thermal protection compressor 2 Sys 2 auto reset | |
| 129 | Thermal protection compressor 3 Sys 2 auto reset | |
| 130 | Fan Thermal protection auto reset | |
| 131 | Fan Thermal protection Group 1 Sys 1 auto reset | |
| 132 | Fan Thermal protection Group 2 Sys 1 auto reset | |
| 133 | Fan Thermal protection Group 1 Sys 2 auto reset | |
| 134 | Fan Thermal protection Group 2 Sys 2 auto reset | |
| 135 | Low refrigerant cutout Sys 1 auto reset | |
| 136 | Low refrigerant cutout Sys 2 auto reset | |
| 137 | Low pressure alarm Sys 1 auto reset | |
| 138 | Low pressure alarm Sys 2 auto reset | |
| 139 | Out of envelope Sys 1 auto reset | |
| 140 | Out of envelope Sys 2 auto reset | |
| 141 | High pressure Sys 1 auto reset | |
| 142 | High pressure Sys 2 auto reset | |
| 143 | High limit discharge temperature Sys1 auto reset | |
| 144 | High limit discharge temperature Sys2 auto reset | |

6 - Control (continued)

6.4 Protection and Safety Equipment

Defrosting System (only for HP models)

The HP units are provided with an automatic defrosting system, which prevents the formation of excessive ice banks on coolant/air exchangers during heat pump operation.

This system, which is part of the electronic control system, is of the time/suction pressure type, and when the suction pressure detected by a sensor drops below a fixed limit, once the preset time is over, switches from heating to cooling the operation of the unit, with the fans stopped.

During the defrosting cycle the compressor works normally, but the coil's fans remain off. The defrosting cycle stops after the coil has been defrosted, and at this point the unit can work in heating mode again.

| | |
|---|---|
|  | <p>Both circuits are defrosted at the same time. For safety purposes, fans are started also during defrosting, if the discharge pressure reaches considerable values.</p> |
|---|---|

Frost Protection for the Chilled Fluid

These units are provided with frost protection for the chilled fluid. This protection consists of an electrical resistor positioned in contact with the coolant/circulating fluid exchanger, which is activated (although the unit is off) when the temperature of the fluid drops below 5 °C - the standard value for a non-glycol unit.

If the leaving water temperature drops below 4 °C (standard value for a non-glycol unit) the machine's antifreeze alarm is activated. If the circulating fluid is water, before the beginning of the cold season it is advisable to drain the circuit to prevent water frosting.

If the circuit cannot be drained, it is essential to avoid de-energizing the unit, so as to permit the activation, when necessary, of the frost protection.

Compressor protection

Compressors are equipped with a heating element to prevent oil dilution, which may result in remarkable risks of failure of compressors.

The windings of the compressors' motors are provided with a thermal protection.

For models an accessory kit for thermal protection is available, for any overcurrent of scroll compressors, which shall be shop-mounted.

Electrical flow switch

To ensure the correct operation of the unit, a electrical flow switch must be installed, to prevent the unit working in case of insufficient circulation of the chilled fluid.

| | |
|---|---|
|  | <p>The electrical flow switch must be carefully installed, according to the instructions given by the Manufacturer.</p> |
|---|---|

The electrical flow switch must be installed on the pressing side of the circulation pump for the fluid, just after the heat exchanger's inlet. The electrical flow switch must be installed in a horizontal straight length of piping, in a position reasonably far (both upstream and downstream) from localized pressure drops (curves, valves etc.).

Differential pressure switch

This pressure switch halts the operation of the unit in the event that it does not detect a sufficient pressure drop through the exchanger.

6 - Control (continued)

6.5 HPF version configuration

Units equipped with High pressure fan (HPF) can be set-up on the field to give the unit a specific static pressure.

By entering parameter in service level - Max Speed (Vdc) - it is

possible to modify high static pressure. The table below shows the correspondance between chiller model, fan RPM, high static pressure.

| Size | Fan Static Pressure (Pa) | Fan RPM | Parameter in Service Level: Max Speed (Vdc) |
|---------|--------------------------|---------|--|
| 240-660 | 0 | 900 | 8.1 |
| | 25 | 950 | 8.5 |
| | 56 | 1.000 | 9.0 |
| | 88 | 1.050 | 9.4 |
| | 124 | 1.100 | 10.0 |

7 - Product Description

7.1 General Information

Units are one-block type with double refrigerant circuit. They are intended to cool down the water required for any air-conditioning application as well as any other fluid, such as for example glycol water. These units are completely assembled at works. They are equipped with all the refrigerating connections and the internal electrical wiring required for a rapid installation on the field. An operation test is performed after assembly, with water flowing through the refrigerant/water exchanger in order to make sure that the refrigerating circuit is properly working. The refrigerating circuit of every unit is pressure tested before inspection, drained and charged with R410A. A low noise level is the result of a careful study. It is achieved on chillers by using technologically advanced components without negatively affecting the operation performances and limits of the units.

7.2 Body and Frame

The base and frame of these units are made with galvanized steel elements, assembled with stainless steel screws. All panels can be removed to ensure easy access to internal components. All galvanized steel parts are protected by epoxy powder paint.

7.3 Compressors

The models are equipped with SCROLL hermetic compressors with an internal motor protection. The compressors of all models are assembled on rubber shock absorbers. Their motors can be directly started. They are cooled down by the aspirated refrigerant gas and equipped with internal thermistor protections against overloads. Overload protections are automatically reset after having tripped. The compressor terminal box has an IP21/54 protection degree. Compressors are powered on and off by the microprocessor of the unit control system which is intended to control the delivery of the thermal refrigerating capacity.

7.4 Evaporators

Evaporators are made of stainless steel plates. They are thermally insulated by means of a thick flexible insulating mattress with closed cells. The maximum operating pressures correspond to 10 bar for the water side and to 45 bar for the refrigerant side. Antifreeze protection for the water in the exchangers is ensured by electrical heaters and differential pressure switches.

7.5 Condensing/evaporating coils

Coils are of reversible type and are made of copper tubes arranged in staggered rows and mechanically expanded inside an aluminium finned pack. The maximum operating pressure on the refrigerant side of the condensing coils is 45 bar. The condensing coils mounted on cooling only units are of microchannel type.

7.6 Condenser Fans

The condenser fans are of a helical type. They are directly coupled and have an impeller with wing contoured aluminium blades. Each fan is equipped with a galvanised steel accident-prevention protection which is painted after manufacture. The fans motors are completely closed. They have an IP54 protection degree and a protection thermostat embedded in the windings.

7.7 Fans Control

All models have a step speed controller as a standard. It will act according to the condensing pressure and allow the operation down to an Air temperature operation of +10°C.

7.8 Refrigerating Circuit

Each unit has double refrigerating circuit equipped with external service valves intended to measure the refrigerant pressure and charge, sight glass with a humidity indicator, dryer filter and thermal expansion valve. Refrigerating circuit is also complete with high and low pressure switch as well as high and low transducer.

7.9 Control Supply Panel

All components of the control system and those necessary to start the motors are shop connected and tested. The control compartment contains an electronic card and a control board with an external keyboard and display, to show the operational functions, as well as the intervention of the alarms and the working blocks.

7 - Product Description (continued)

Refrigerant flow diagram - SyScroll Air CO

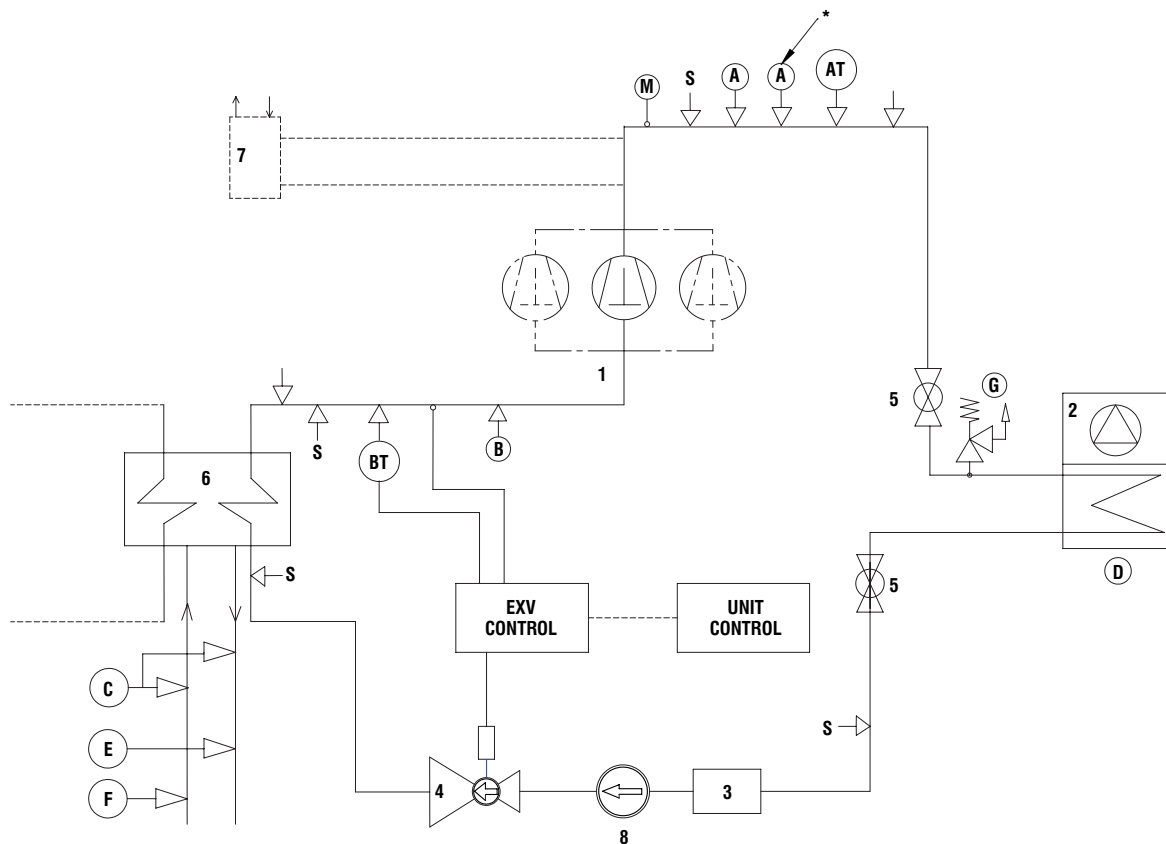

| COMPONENTS | |
|------------|----------------------------|
| 1 | Scroll type compressor |
| 2 | Air cooled condenser |
| 3 | Filter drier |
| 4 | Electronic expansion valve |
| 5 | Globe valve |
| 6 | Heat exchanger |
| 7 | Desuperheater (optional) |
| 8 | Sight glass |

| SAFETY / CONTROL DEVICES | |
|--------------------------|--|
| A | High pressure switch |
| AT | High pressure trasducer |
| B | Low pressure switch |
| BT | Low pressure trasducer |
| C | Water differential pressure switch |
| D | Air temperature sensor |
| E | Outlet water temperature sensor |
| F | Inlet water temperature sensor |
| G | PED pressure relief valve (45 bar) |
| M | Discharge temperature sensor |
| S | 5/16" Schrader connection (service only) |
| ↓ | Pipe connection with Schrader valve |

| SIZE | N° COMPRESSORS | | N° HP SWITCH (*) | |
|------|----------------|--------|------------------|--------|
| | CIRC.1 | CIRC.2 | CIRC.1 | CIRC.2 |
| 240 | 1 | 2 | NO | YES |
| 270 | 1 | 2 | NO | YES |
| 290 | 1 | 2 | NO | YES |
| 320 | 1 | 2 | NO | YES |
| 360 | 2 | 2 | YES | YES |
| 420 | 2 | 2 | YES | YES |
| 470 | 2 | 3 | YES | YES |
| 540 | 2 | 3 | YES | YES |
| 590 | 3 | 3 | YES | YES |
| 660 | 3 | 3 | YES | YES |

7 - Product Description (continued)

Refrigerant flow diagram - SyScroll Air HP

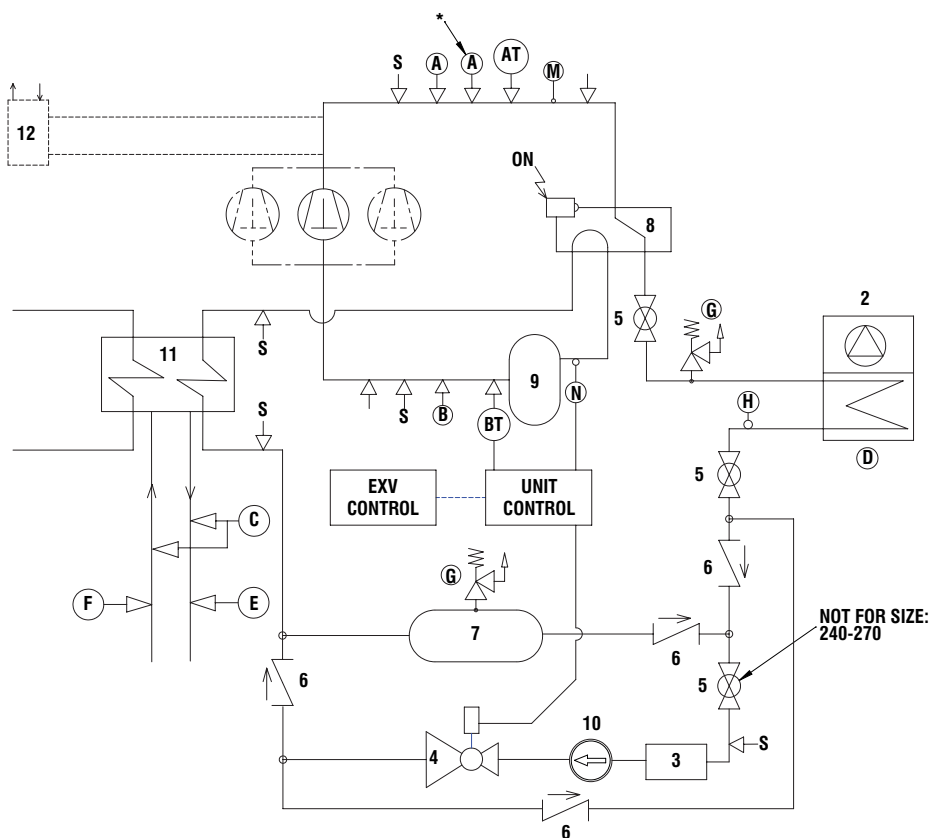

| COMPONENTS | |
|------------|----------------------------|
| 1 | Scroll type compressor |
| 2 | Air cooled condenser |
| 3 | Filter drier |
| 4 | Electronic expansion valve |
| 5 | Globe valve |
| 6 | Check valve |
| 7 | Liquid receiver |
| 8 | Four-way valve |
| 9 | Suction accumulator |
| 10 | Sight glass |
| 11 | Heat exchanger |
| 12 | Desuperheater (option) |

| SAFETY/CONTROL DEVICES | |
|------------------------|---------------------------------------|
| A | High pressure switch |
| AT | High pressure trasducer |
| B | Low pressure switch |
| BT | Low pressure trasducer |
| C | Water differential pressure switch |
| D | Air temperature sensor |
| E | Outlet water temperature sensor |
| F | Inlet water temperature sensor |
| G | PED pressure relief valve |
| H | Defrost temperature sensor |
| M | Discharge temperature sensor |
| N | Suction temperature sensor |
| S | 5/16" valve connection (service only) |
| ↓ | Pipe connection with Shrader valve |

| SIZE | N° COMPRESSORS | | N° HP SWITCH (*) | |
|------|----------------|--------|------------------|--------|
| | CIRC.1 | CIRC.2 | CIRC.1 | CIRC.2 |
| 240 | 1 | 2 | NO | YES |
| 270 | 1 | 2 | NO | YES |
| 290 | 1 | 2 | NO | YES |
| 320 | 1 | 2 | NO | YES |
| 360 | 2 | 2 | YES | YES |
| 420 | 2 | 2 | YES | YES |
| 470 | 2 | 3 | YES | YES |
| 540 | 2 | 3 | YES | YES |
| 590 | 3 | 3 | YES | YES |
| 660 | 3 | 3 | YES | YES |

7 - Product Description (continued)

Refrigerant flow diagram - SyScroll Air RE

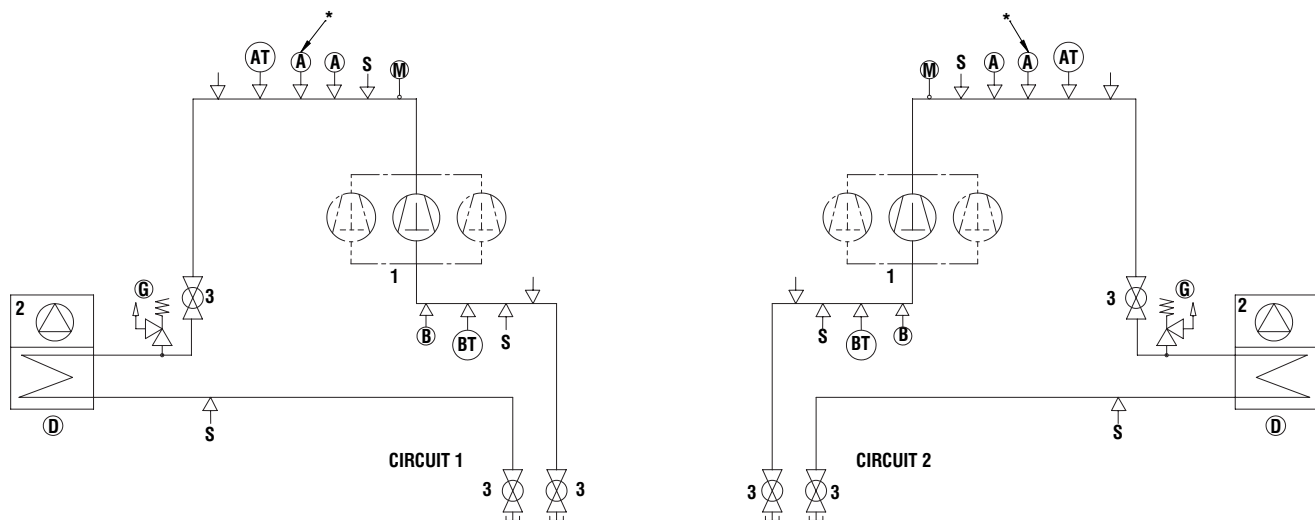

| COMPONENTS | |
|------------|------------------------|
| 1 | Scroll type compressor |
| 2 | Air cooled condenser |
| 3 | Globe valve |

| SAFETY / CONTROL DEVICES | |
|--------------------------|--|
| A | High pressure switch (40,5 bar) |
| AT | High pressure trasducer |
| AF | Access fitting sae flare 1/4" |
| B | Low pressure switch (1,5 bar) |
| BT | Low pressure trasducer |
| D | Air temperature sensor |
| G | PED pressure relief valve (45 bar) |
| M | Discharge temperature sensor |
| S | 5/16" Schrader connection (service only) |
| ↓ | Pipe connection with Schrader valve |

| SIZE | N° COMPRESSORS | | N° HP SWITCH (*) | |
|------|----------------|--------|------------------|--------|
| | CIRC.1 | CIRC.2 | CIRC.1 | CIRC.2 |
| 240 | 1 | 2 | NO | SI |
| 270 | 1 | 2 | NO | SI |
| 290 | 1 | 2 | NO | SI |
| 320 | 1 | 2 | NO | SI |
| 360 | 2 | 2 | SI | SI |
| 420 | 2 | 2 | SI | SI |
| 470 | 2 | 3 | SI | SI |
| 540 | 2 | 3 | SI | SI |
| 590 | 3 | 3 | SI | SI |
| 660 | 3 | 3 | SI | SI |

7 - Product Description (continued)

Refrigerant flow diagram - SyScroll Air TR

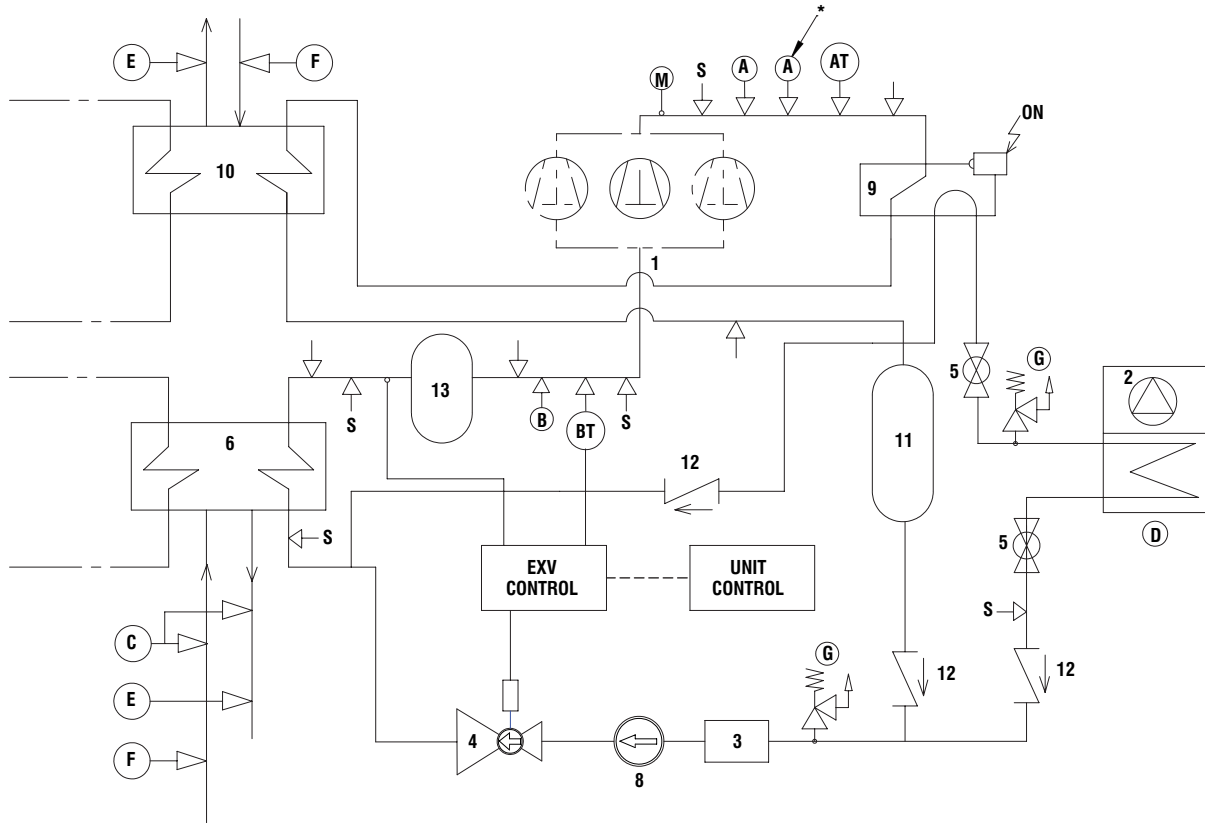

| COMPONENTS | |
|------------|----------------------------|
| 1 | Scroll type compressor |
| 2 | Air cooled condenser |
| 3 | Filter drier |
| 4 | Electronic expansion valve |
| 5 | Globe valve |
| 6 | Heat exchange |
| 7 | Desuperheaters (optional) |
| 8 | Sight glass |
| 9 | Four-way valve |
| 10 | Heat recover |
| 11 | Liquid receiver |
| 12 | Check valve |
| 13 | Suction |

| SAFETY/CONTROL DEVICES | |
|------------------------|---|
| A | High pressure switch (40.5 bar) |
| AT | High pressure trasducer |
| B | Low pressure switch (1.5 bar) |
| BT | Low pressure trasducer |
| C | Water differential pressure switch (105 mbar) |
| D | Air temperature sensor |
| E | Outlet water temperature sensor |
| F | Inlet water temperature sensor |
| G | PED pressure relief valve (45 bar) |
| M | Discharge temperature sensor |
| N | Suction temperature sensor |
| S | 5/16" shradet connection (service only) |
| ↓ | Pipe connection with Shrader valve |

| SIZE | N° COMPRESSORS | | N° HP SWITCH (*) | |
|------|----------------|--------|------------------|--------|
| | CIRC.1 | CIRC.2 | CIRC.1 | CIRC.2 |
| 240 | 1 | 2 | NO | YES |
| 270 | 1 | 2 | NO | YES |
| 290 | 1 | 2 | NO | YES |
| 320 | 1 | 2 | NO | YES |
| 360 | 2 | 2 | YES | YES |
| 420 | 2 | 2 | YES | YES |
| 470 | 2 | 3 | YES | YES |
| 540 | 2 | 3 | YES | YES |
| 590 | 3 | 3 | YES | YES |
| 660 | 3 | 3 | YES | YES |

8 - Technical Data

8.1 Pressure drops

| EVAPORATOR PRESSURE DROP - SYSCROLL Air CO | | 240 | 270 | 290 | 320 | 360 | 420 | 470 | 540 | 590 | 660 |
|---|-----|------------|------------|------------|------------|------------|------------|------------|------------|------------|------------|
| Minimum flow rate | l/s | 8.2 | 9.2 | 9.9 | 10.8 | 12.4 | 14.2 | 16.1 | 18.3 | 20.2 | 22.4 |
| Nominal flow rate | l/s | 11.4 | 12.8 | 13.8 | 15.1 | 17.4 | 19.9 | 22.5 | 25.6 | 28.3 | 31.4 |
| Maximum flow rate | l/s | 19.0 | 21.4 | 23.0 | 25.2 | 28.9 | 33.1 | 37.5 | 42.7 | 47.1 | 52.3 |
| Minimum pressure drop | kPa | 26 | 33 | 38 | 18 | 24 | 31 | 23 | 30 | 28 | 35 |
| Nominal pressure drop | kPa | 50 | 62 | 72 | 35 | 45 | 58 | 44 | 57 | 54 | 66 |
| Maximum pressure drop | kPa | 134 | 168 | 194 | 92 | 120 | 156 | 118 | 152 | 145 | 179 |

| EVAPORATOR PRESSURE DROP - SYSCROLL Air HP | | 240 | 270 | 290 | 320 | 360 | 420 | 470 | 540 | 590 | 660 |
|---|-----|------------|------------|------------|------------|------------|------------|------------|------------|------------|------------|
| Minimum flow rate | l/s | 7.4 | 8.6 | 9.0 | 9.8 | 11.3 | 13.0 | 14.9 | 16.5 | 18.2 | 19.9 |
| Nominal flow rate | l/s | 10.4 | 12.1 | 12.7 | 13.8 | 15.8 | 18.3 | 20.9 | 23.1 | 25.4 | 27.9 |
| Maximum flow rate | l/s | 17.3 | 20.1 | 21.1 | 22.9 | 26.4 | 30.4 | 34.8 | 38.5 | 42.4 | 46.4 |
| Minimum pressure drop | kPa | 22 | 29 | 32 | 15 | 20 | 26 | 20 | 24 | 23 | 28 |
| Nominal pressure drop | kPa | 42 | 55 | 61 | 29 | 38 | 50 | 38 | 46 | 44 | 53 |
| Maximum pressure drop | kPa | 111 | 149 | 164 | 77 | 100 | 132 | 102 | 125 | 119 | 141 |

| CONDENSER PRESSURE DROP - SYSCROLL Air HP | | 240 | 270 | 290 | 320 | 360 | 420 | 470 | 540 | 590 | 660 |
|--|-----|------------|------------|------------|------------|------------|------------|------------|------------|------------|------------|
| Minimum flow rate | l/s | 8.7 | 9.8 | 10.6 | 11.3 | 13.0 | 15.1 | 16.7 | 18.9 | 20.6 | 23.1 |
| Nominal flow rate | l/s | 12.2 | 13.7 | 14.9 | 15.9 | 18.2 | 21.1 | 23.4 | 26.5 | 28.8 | 32.3 |
| Maximum flow rate | l/s | 20.3 | 22.9 | 24.8 | 26.4 | 30.3 | 35.2 | 39.0 | 44.1 | 48.0 | 53.8 |
| Minimum pressure drop | kPa | 30 | 37 | 43 | 20 | 26 | 34 | 25 | 32 | 29 | 37 |
| Nominal pressure drop | kPa | 56 | 71 | 83 | 38 | 49 | 65 | 48 | 60 | 56 | 70 |
| Maximum pressure drop | kPa | 151 | 192 | 224 | 101 | 131 | 175 | 128 | 162 | 151 | 189 |

| DESUPERHEATER PRESSURE DROP | | 240 | 270 | 290 | 320 | 360 | 420 | 470 | 540 | 590 | 660 |
|------------------------------------|-----|------------|------------|------------|------------|------------|------------|------------|------------|------------|------------|
| Minimum flow rate | l/s | 2.1 | 2.4 | 2.6 | 2.8 | 3.3 | 3.7 | 4.2 | 4.8 | 5.2 | 5.8 |
| Nominal flow rate | l/s | 3.0 | 3.4 | 3.6 | 4.0 | 4.6 | 5.2 | 5.9 | 6.7 | 7.3 | 8.2 |
| Maximum flow rate | l/s | 5.0 | 5.7 | 6.1 | 6.6 | 7.6 | 8.7 | 9.8 | 11.2 | 12.2 | 13.6 |
| Minimum pressure drop | kPa | 8 | 10 | 11 | 14 | 11 | 14 | 13 | 17 | 16 | 20 |
| Nominal pressure drop | kPa | 15 | 20 | 22 | 27 | 21 | 28 | 26 | 34 | 32 | 40 |
| Maximum pressure drop | kPa | 42 | 54 | 61 | 74 | 58 | 77 | 72 | 94 | 90 | 111 |

8 - Technical Data (continued)

8.2 Technical data

| SyScroll Air CO _ | | 240 | 270 | 290 | 320 | 360 | 420 | 470 | 540 | 590 | 660 |
|--|---------|----------------------|-----------|-----------|-----------|--------------|--------------|-----------------|------------------|--------------------|--------------------|
| Power supply | V/ph/Hz | 400 (± 10%) / 3 / 50 | | | | | | | | | |
| Total capacity steps | % | 31-62-100 | 33-67-100 | 30-60-100 | 27-64-100 | 23-46-69-100 | 25-50-75-100 | 24-47-65-82-100 | 20-40-60-800-100 | 14-29-43-62-81-100 | 17-33-50-67-83-100 |
| REFRIGERANT | | | | | | | | | | | |
| Type | | R410A | | | | | | | | | |
| COMPRESSOR | | | | | | | | | | | |
| Number | | 3 | 3 | 3 | 3 | 4 | 4 | 5 | 5 | 6 | 6 |
| Type | | Scroll | | | | | | | | | |
| N° of loading stages | | 0/100 | 0/100 | 0/100 | 0/100 | 0/100 | 0/100 | 0/100 | 0/100 | 0/100 | 0/100 |
| EVAPORATOR | | | | | | | | | | | |
| Number | | 1 | 1 | 1 | 1 | 1 | 1 | 1 | 1 | 1 | 1 |
| Type | | Plate | | | | | | | | | |
| Water flow | m³/h | 41.1 | 46.2 | 49.7 | 54.5 | 62.5 | 71.6 | 81.1 | 92.2 | 101.7 | 113.1 |
| Pressure drop | kPa | 50 | 62 | 72 | 35 | 45 | 58 | 44 | 57 | 54 | 66 |
| Water volume | l | 14 | 14 | 14 | 24 | 24 | 24 | 32 | 32 | 39 | 39 |
| Antifreeze Heater | W | 130 | 130 | 130 | 130 | 130 | 130 | 130 | 130 | 130 | 130 |
| AIR COOLED CONDENSER | | | | | | | | | | | |
| Number of coils | | 5 | 5 | 6 | 6 | 7 | 8 | 9 | 10 | 11 | 12 |
| Total coil face area per coil | m² | 2.4 | 2.4 | 2.4 | 2.4 | 2.4 | 2.4 | 2.4 | 2.4 | 2.4 | 2.4 |
| FANS | | | | | | | | | | | |
| Number of fans | | 5 | 5 | 6 | 6 | 7 | 8 | 9 | 10 | 11 | 12 |
| Nominal speed | rpm | 900 | 900 | 900 | 900 | 900 | 900 | 900 | 900 | 900 | 900 |
| Total airflow | m³/h | 112.500 | 112.500 | 135.000 | 135.000 | 157.500 | 180.000 | 202.500 | 225.000 | 247.500 | 270.000 |
| Total input power | kW | 8.5 | 8.5 | 10.2 | 10.2 | 11.9 | 13.6 | 15.3 | 17.0 | 18.7 | 20.4 |
| Total input power(*) | kW | 7.5 | 7.5 | 9.0 | 9.0 | 10.5 | 12.0 | 13.5 | 15.0 | 16.5 | 18.0 |
| Total input power(**) | kW | 13.0 | 13.0 | 15.6 | 15.6 | 18.2 | 20.8 | 23.4 | 26.0 | 28.6 | 31.2 |
| External static pressure | Pa | 0 or 120 Pa (**) | | | | | | | | | |
| WATER CONNECTIONS (EVAPORATOR) | | | | | | | | | | | |
| Type | | Male GAS Threaded | | | | | Victaulic | | | | |
| Inlet Diameter | inch | 3" | 3" | 3" | 3" | 4" | 4" | 4" | 4" | 5" | 5" |
| Outlet Diameter | inch | 3" | 3" | 3" | 3" | 4" | 4" | 4" | 4" | 5" | 5" |
| WATER CONNECTIONS (DESUPERHEATER) | | | | | | | | | | | |
| Type | | Male GAS Threaded | | | | | | | | | |
| Inlet Diameter / Outlet Diameter | inch | 1" / 1" | | | | | | | | | |
| WEIGHT | | | | | | | | | | | |
| Shipping | kg | 1.772 | 1.773 | 1.865 | 1.921 | 2.306 | 2.417 | 2.897 | 3.009 | 3.412 | 3.509 |
| Operating | kg | 1.786 | 1.787 | 1.879 | 1.945 | 2.330 | 2.441 | 2.934 | 3.047 | 3.456 | 3.553 |
| DIMENSIONS | | | | | | | | | | | |
| Length | mm | 3.500 | 3.500 | 3.500 | 3.500 | 4.550 | 4.550 | 5.600 | 5.600 | 6.650 | 6.650 |
| Width | mm | 2.150 | 2.150 | 2.150 | 2.150 | 2.150 | 2.150 | 2.150 | 2.150 | 2.150 | 2.150 |
| Height | mm | 2.600 | 2.600 | 2.600 | 2.600 | 2.600 | 2.600 | 2.600 | 2.600 | 2.600 | 2.600 |

(*) High temperature version (HT).

(**) HPF Units with high static pressure fans.

8 - Technical Data (continued)

| SyScroll Air CO _ L | | 240 | 270 | 290 | 320 | 360 | 420 | 470 | 540 | 590 | 660 |
|--|-------------------|----------------------|-----------|-----------|-----------|--------------|--------------|-----------------|------------------|--------------------|--------------------|
| Power supply | V/ph/Hz | 400 (± 10%) / 3 / 50 | | | | | | | | | |
| Total capacity steps | % | 31-62-100 | 33-67-100 | 30-60-100 | 27-64-100 | 23-46-69-100 | 25-50-75-100 | 24-47-65-82-100 | 20-40-60-800-100 | 14-29-43-62-81-100 | 17-33-50-67-83-100 |
| REFRIGERANT | | | | | | | | | | | |
| Type | | R410A | | | | | | | | | |
| COMPRESSOR | | | | | | | | | | | |
| Number | | 3 | 3 | 3 | 3 | 4 | 4 | 5 | 5 | 6 | 6 |
| Type | | Scroll | | | | | | | | | |
| N° of loading stages | | 0/100 | 0/100 | 0/100 | 0/100 | 0/100 | 0/100 | 0/100 | 0/100 | 0/100 | 0/100 |
| EVAPORATOR | | | | | | | | | | | |
| Number | | 1 | 1 | 1 | 1 | 1 | 1 | 1 | 1 | 1 | 1 |
| Type | | Plate | | | | | | | | | |
| Water flow | m ³ /h | 39.7 | 44.4 | 48.0 | 52.4 | 60.2 | 68.9 | 78.0 | 88.6 | 97.8 | 108.6 |
| Pressure drop | kPa | 47 | 58 | 67 | 32 | 42 | 54 | 41 | 52 | 50 | 61 |
| Water volume | l | 14 | 14 | 14 | 24 | 24 | 24 | 32 | 32 | 39 | 39 |
| Antifreeze Heater | W | 130 | 130 | 130 | 130 | 130 | 130 | 130 | 130 | 130 | 130 |
| AIR COOLED CONDENSER | | | | | | | | | | | |
| Number of coils | | 5 | 5 | 6 | 6 | 7 | 8 | 9 | 10 | 11 | 12 |
| Total coil face area per coil | m ² | 2.4 | 2.4 | 2.4 | 2.4 | 2.4 | 2.4 | 2.4 | 2.4 | 2.4 | 2.4 |
| FANS | | | | | | | | | | | |
| Number of fans | | 5 | 5 | 6 | 6 | 7 | 8 | 9 | 10 | 11 | 12 |
| Nominal speed | rpm | 700 | 700 | 700 | 700 | 700 | 700 | 700 | 700 | 700 | 700 |
| Total airflow | m ³ /h | 92.500 | 92.500 | 111.000 | 111.000 | 129.500 | 148.000 | 166.500 | 185.000 | 203.500 | 222.000 |
| Total input power | kW | 6.0 | 6.0 | 7.2 | 7.2 | 8.4 | 9.6 | 10.8 | 12.0 | 13.2 | 14.4 |
| WATER CONNECTIONS (EVAPORATOR) | | | | | | | | | | | |
| Type | | Male GAS Threaded | | | | | Victaulic | | | | |
| Inlet Diameter | inch | 3" | 3" | 3" | 3" | 4" | 4" | 4" | 4" | 5" | 5" |
| Outlet Diameter | inch | 3" | 3" | 3" | 3" | 4" | 4" | 4" | 4" | 5" | 5" |
| WATER CONNECTIONS (DESUPERHEATER) | | | | | | | | | | | |
| Type | | Male GAS Threaded | | | | | | | | | |
| Inlet Diameter | inch | 1" | | | | | | | | | |
| Outlet Diameter | inch | 1" | | | | | | | | | |
| WEIGHT | | | | | | | | | | | |
| Shipping | kg | 1.772 | 1.773 | 1.865 | 1.921 | 2.306 | 2.417 | 2.897 | 3.009 | 3.412 | 3.509 |
| Operating | kg | 1.786 | 1.787 | 1.879 | 1.945 | 2.330 | 2.441 | 2.934 | 3.047 | 3.456 | 3.553 |
| DIMENSIONS | | | | | | | | | | | |
| Length | mm | 3.500 | 3.500 | 3.500 | 3.500 | 4.550 | 4.550 | 5.600 | 5.600 | 6.650 | 6.650 |
| Width | mm | 2.150 | 2.150 | 2.150 | 2.150 | 2.150 | 2.150 | 2.150 | 2.150 | 2.150 | 2.150 |
| Height | mm | 2.600 | 2.600 | 2.600 | 2.600 | 2.600 | 2.600 | 2.600 | 2.600 | 2.600 | 2.600 |

8 - Technical Data (continued)

| SyScroll Air CO _ S | | 240 | 270 | 290 | 320 | 360 | 420 | 470 | 540 | 590 | 660 |
|--|---------|-------------------|-----------|-----------|-----------|--------------|--------------|-----------------|------------------|--------------------|--------------------|
| Power supply | V/ph/Hz | 400V/3/50Hz | | | | | | | | | |
| Total capacity steps | % | 31-62-100 | 33-67-100 | 30-60-100 | 27-64-100 | 23-46-69-100 | 25-50-75-100 | 24-47-65-82-100 | 20-40-60-800-100 | 14-29-43-62-81-100 | 17-33-50-67-83-100 |
| REFRIGERANT | | | | | | | | | | | |
| Type | | R410A | | | | | | | | | |
| COMPRESSOR | | | | | | | | | | | |
| Number | | 3 | 3 | 3 | 3 | 4 | 4 | 5 | 5 | 6 | 6 |
| Type | | Scroll | | | | | | | | | |
| N° of loading stages | | 0/100 | 0/100 | 0/100 | 0/100 | 0/100 | 0/100 | 0/100 | 0/100 | 0/100 | 0/100 |
| EVAPORATOR | | | | | | | | | | | |
| Number | | 1 | 1 | 1 | 1 | 1 | 1 | 1 | 1 | 1 | 1 |
| Type | | Plate | | | | | | | | | |
| Water flow | m³/h | 37.0 | 40.9 | 44.8 | 48.4 | 55.7 | 63.7 | 72.2 | 81.9 | 90.5 | 100.3 |
| Pressure drop | kPa | 41 | 49 | 59 | 28 | 36 | 47 | 35 | 45 | 43 | 53 |
| Water volume | l | 14 | 14 | 14 | 24 | 24 | 24 | 32 | 32 | 39 | 39 |
| Antifreeze Heater | W | 130 | 130 | 130 | 130 | 130 | 130 | 130 | 130 | 130 | 130 |
| AIR COOLED CONDENSER | | | | | | | | | | | |
| Number of coils | | 5 | 5 | 6 | 6 | 7 | 8 | 9 | 10 | 11 | 12 |
| Total coil face area per coil | m² | 2.4 | 2.4 | 2.4 | 2.4 | 2.4 | 2.4 | 2.4 | 2.4 | 2.4 | 2.4 |
| FANS | | | | | | | | | | | |
| Number of fans | | 5 | 5 | 6 | 6 | 7 | 8 | 9 | 10 | 11 | 12 |
| Nominal speed | rpm | 550 | 550 | 550 | 550 | 550 | 550 | 550 | 550 | 550 | 550 |
| Total airflow | m³/h | 72.500 | 72.500 | 87.000 | 87.000 | 101.500 | 116.000 | 130.500 | 145.000 | 159.500 | 174.000 |
| Total input power | kW | 4.5 | 4.5 | 5.4 | 5.4 | 6.3 | 7.2 | 8.1 | 9.0 | 9.9 | 10.8 |
| WATER CONNECTIONS (EVAPORATOR) | | | | | | | | | | | |
| Type | | Male GAS Threaded | | | | | Victaulic | | | | |
| Inlet Diameter | inch | 3" | 3" | 3" | 3" | 4" | 4" | 4" | 4" | 5" | 5" |
| Outlet Diameter | inch | 3" | 3" | 3" | 3" | 4" | 4" | 4" | 4" | 5" | 5" |
| WATER CONNECTIONS (DESUPERHEATER) | | | | | | | | | | | |
| Type | | Male GAS Threaded | | | | | | | | | |
| Inlet Diameter | inch | 1" | | | | | | | | | |
| Outlet Diameter | inch | 1" | | | | | | | | | |
| WEIGHT | | | | | | | | | | | |
| Shipping | kg | 1.772 | 1.773 | 1.865 | 1.921 | 2.306 | 2.417 | 2.897 | 3.009 | 3.412 | 3.509 |
| Operating | kg | 1.786 | 1.787 | 1.879 | 1.945 | 2.330 | 2.441 | 2.934 | 3.047 | 3.456 | 3.553 |
| DIMENSIONS | | | | | | | | | | | |
| Length | mm | 3.500 | 3.500 | 3.500 | 3.500 | 4.550 | 4.550 | 5.600 | 5.600 | 6.650 | 6.650 |
| Width | mm | 2.150 | 2.150 | 2.150 | 2.150 | 2.150 | 2.150 | 2.150 | 2.150 | 2.150 | 2.150 |
| Height | mm | 2.600 | 2.600 | 2.600 | 2.600 | 2.600 | 2.600 | 2.600 | 2.600 | 2.600 | 2.600 |

8 - Technical Data (continued)

| SyScroll Air HP | | 240 | 270 | 290 | 320 | 360 | 420 | 470 | 540 | 590 | 660 |
|--|---------|----------------------|------------|------------|------------|--------------|--------------|-----------------|-----------------|--------------------|--------------------|
| Power supply | V/ph/Hz | 400 (± 10%) / 3 / 50 | | | | | | | | | |
| Total capacity steps | % | 31-62-100 | 33-67-100 | 30-60-100 | 27-64-100 | 23-46-69-100 | 25-50-75-100 | 24-47-65-82-100 | 20-40-60-80-100 | 14-29-43-62-81-100 | 17-33-50-67-83-100 |
| REFRIGERANT | | | | | | | | | | | |
| Type | | R410A | | | | | | | | | |
| COMPRESSOR | | | | | | | | | | | |
| Number | | 3 | 3 | 3 | 3 | 4 | 4 | 5 | 5 | 6 | 6 |
| Type | | Scroll | | | | | | | | | |
| N° of loading stages | | 0/100 | 0/100 | 0/100 | 0/100 | 0/100 | 0/100 | 0/100 | 0/100 | 0/100 | 0/100 |
| EVAPORATOR | | | | | | | | | | | |
| Number | | 1 | 1 | 1 | 1 | 1 | 1 | 1 | 1 | 1 | 1 |
| Type | | Plate | | | | | | | | | |
| Water flow cooling | m³/h | 37.4 | 43.5 | 45.6 | 49.5 | 57.0 | 65.8 | 75.1 | 83.2 | 91.6 | 100.3 |
| Pressure drop cooling | kPa | 42 | 55 | 61 | 29 | 38 | 50 | 38 | 46 | 44 | 53 |
| Water flow heating | m³/h | 43.8 | 49.4 | 53.5 | 57.1 | 65.5 | 76.0 | 84.2 | 95.3 | 103.6 | 116.2 |
| Pressure drop heating | kPa | 56 | 71 | 83 | 38 | 49 | 65 | 48 | 60 | 56 | 70 |
| Water volume | l | 14 | 14 | 14 | 24 | 24 | 24 | 32 | 32 | 39 | 39 |
| Antifreeze Heater | W | 130 | 130 | 130 | 130 | 130 | 130 | 130 | 130 | 130 | 130 |
| AIR COOLED CONDENSER | | | | | | | | | | | |
| Number of coils | | 5 | 5 | 6 | 6 | 7 | 8 | 9 | 10 | 11 | 12 |
| Total coil face area per coil | m² | 2.4 | 2.4 | 2.4 | 2.4 | 2.4 | 2.4 | 2.4 | 2.4 | 2.4 | 2.4 |
| FANS | | | | | | | | | | | |
| Number of fans | | 5 | 5 | 6 | 6 | 7 | 8 | 9 | 10 | 11 | 12 |
| Nominal speed | rpm | 900 | 900 | 900 | 900 | 900 | 900 | 900 | 900 | 900 | 900 |
| Total airflow | m³/h | 107.500 | 107.500 | 129.000 | 129.000 | 150.500 | 172.000 | 193.500 | 215.000 | 236.500 | 258.000 |
| Total input power | kW | 8.5 | 8.5 | 10.2 | 10.2 | 11.9 | 13.6 | 15.3 | 17.0 | 18.7 | 20.4 |
| Total input power (*) | kW | 7.5 | 7.5 | 9.0 | 9.0 | 10.5 | 12.0 | 13.5 | 15.0 | 16.5 | 18.0 |
| Total input power (**) | kW | 13.0 | 13.0 | 15.6 | 15.6 | 18.2 | 20.8 | 23.4 | 26.0 | 28.6 | 31.2 |
| External static pressure | Pa | 0 or 120 Pa (**) | | | | | | | | | |
| WATER CONNECTIONS (EVAPORATOR) | | | | | | | | | | | |
| Type | | Male GAS Threaded | | | | | Victaulic | | | | |
| Inlet Diameter | inch | 3" | 3" | 3" | 3" | 4" | 4" | 4" | 4" | 5" | 5" |
| Outlet Diameter | inch | 3" | 3" | 3" | 3" | 4" | 4" | 4" | 4" | 5" | 5" |
| WATER CONNECTIONS (DESUPERHEATER) | | | | | | | | | | | |
| Tipó | | Male GAS Threaded | | | | | | | | | |
| Inlet Diameter / Outlet Diameter | inch | 1" / 1" | | | | | | | | | |
| WEIGHT | | | | | | | | | | | |
| Shipping | kg | 1.934 | 1.935 | 2.041 | 2.098 | 2.509 | 2.634 | 3.151 | 3.278 | 3.718 | 3.829 |
| Operating | kg | 1.948 | 1.949 | 2.055 | 2.122 | 2.534 | 2.659 | 3.189 | 3.316 | 3.762 | 3.873 |
| DIMENSIONS | | | | | | | | | | | |
| Length | mm | 3.500 | 3.500 | 3.500 | 3.500 | 4.550 | 4.550 | 5.600 | 5.600 | 6.650 | 6.650 |
| Width | mm | 2.150 | 2.150 | 2.150 | 2.150 | 2.150 | 2.150 | 2.150 | 2.150 | 2.150 | 2.150 |
| Height | mm | 2.600 | 2.600 | 2.600 | 2.600 | 2.600 | 2.600 | 2.600 | 2.600 | 2.600 | 2.600 |

(*) High temperature version (HT).

(**) HPF Units with high static pressure fans.

8 - Technical Data (continued)

| SyScroll Air HP_L | | 240 | 270 | 290 | 320 | 360 | 420 | 470 | 540 | 590 | 660 |
|--|---------|----------------------|-----------|-----------|-----------|--------------|--------------|-----------------|------------------|--------------------|--------------------|
| Power supply | V/ph/Hz | 400 (± 10%) / 3 / 50 | | | | | | | | | |
| Total capacity steps | % | 31-62-100 | 33-67-100 | 30-60-100 | 27-64-100 | 23-46-69-100 | 25-50-75-100 | 24-47-65-82-100 | 20-40-60-800-100 | 14-29-43-62-81-100 | 17-33-50-67-83-100 |
| REFRIGERANT | | | | | | | | | | | |
| Type | | R410A | | | | | | | | | |
| COMPRESSOR | | | | | | | | | | | |
| Number | | 3 | 3 | 3 | 3 | 4 | 4 | 5 | 5 | 6 | 6 |
| Type | | Scroll | | | | | | | | | |
| N° of loading stages | | 0/100 | 0/100 | 0/100 | 0/100 | 0/100 | 0/100 | 0/100 | 0/100 | 0/100 | 0/100 |
| EVAPORATOR | | | | | | | | | | | |
| Number | | 1 | 1 | 1 | 1 | 1 | 1 | 1 | 1 | 1 | 1 |
| Type | | Plate | | | | | | | | | |
| Water flow cooling | m³/h | 35.4 | 40.8 | 43.2 | 46.5 | 53.7 | 61.9 | 70.7 | 78.2 | 86.2 | 94.2 |
| Water pressure drop cooling | kPa | 37 | 49 | 55 | 26 | 34 | 44 | 34 | 41 | 39 | 47 |
| Water flow heating | m³/h | 43.3 | 48.8 | 52.9 | 56.4 | 64.7 | 75.1 | 83.2 | 92.4 | 102.4 | 114.8 |
| Water pressure drop heating | kPa | 55 | 69 | 81 | 37 | 48 | 64 | 46 | 57 | 55 | 68 |
| Water volume | l | 14 | 14 | 14 | 24 | 24 | 24 | 32 | 32 | 39 | 39 |
| Antifreeze Heater | W | 130 | 130 | 130 | 130 | 130 | 130 | 130 | 130 | 130 | 130 |
| AIR COOLED CONDENSER | | | | | | | | | | | |
| Number of coils | | 5 | 5 | 6 | 6 | 7 | 8 | 9 | 10 | 11 | 12 |
| Total coil face area per coil | m² | 2.4 | 2.4 | 2.4 | 2.4 | 2.4 | 2.4 | 2.4 | 2.4 | 2.4 | 2.4 |
| FANS | | | | | | | | | | | |
| Number of fans | | 5 | 5 | 6 | 6 | 7 | 8 | 9 | 10 | 11 | 12 |
| Nominal speed | rpm | 700 | 700 | 700 | 700 | 700 | 700 | 700 | 700 | 700 | 700 |
| Total airflow | m³/h | 85.000 | 85.000 | 102.000 | 102.000 | 119.000 | 136.000 | 153.000 | 170.000 | 187.000 | 204.000 |
| Total input power | kW | 6.0 | 6.0 | 7.2 | 7.2 | 8.4 | 9.6 | 10.8 | 12.0 | 13.2 | 14.4 |
| WATER CONNECTIONS (EVAPORATOR) | | | | | | | | | | | |
| Type | | Male GAS Threaded | | | | | Victaulic | | | | |
| Inlet Diameter | inch | 3" | 3" | 3" | 3" | 4" | 4" | 4" | 4" | 5" | 5" |
| Outlet Diameter | inch | 3" | 3" | 3" | 3" | 4" | 4" | 4" | 4" | 5" | 5" |
| WATER CONNECTIONS (DESUPERHEATER) | | | | | | | | | | | |
| Type | | Male GAS Threaded | | | | | | | | | |
| Inlet Diameter | inch | 1" | | | | | | | | | |
| Outlet Diameter | inch | 1" | | | | | | | | | |
| WEIGHT | | | | | | | | | | | |
| Shipping | kg | 1.934 | 1.935 | 2.041 | 2.098 | 2.509 | 2.634 | 3.151 | 3.278 | 3.718 | 3.829 |
| Operating | kg | 1.948 | 1.949 | 2.055 | 2.122 | 2.534 | 2.659 | 3.189 | 3.316 | 3.762 | 3.873 |
| DIMENSIONS | | | | | | | | | | | |
| Length | mm | 3.500 | 3.500 | 3.500 | 3.500 | 4.550 | 4.550 | 5.600 | 5.600 | 6.650 | 6.650 |
| Width | mm | 2.150 | 2.150 | 2.150 | 2.150 | 2.150 | 2.150 | 2.150 | 2.150 | 2.150 | 2.150 |
| Height | mm | 2.600 | 2.600 | 2.600 | 2.600 | 2.600 | 2.600 | 2.600 | 2.600 | 2.600 | 2.600 |

8 - Technical Data (continued)

| SyScroll Air HP_S | | 240 | 270 | 290 | 320 | 360 | 420 | 470 | 540 | 590 | 660 |
|--|---------|----------------------|-----------|-----------|-----------|--------------|--------------|-----------------|------------------|--------------------|--------------------|
| Power supply | V/ph/Hz | 400 (± 10%) / 3 / 50 | | | | | | | | | |
| Total capacity steps | % | 31-62-100 | 33-67-100 | 30-60-100 | 27-64-100 | 23-46-69-100 | 25-50-75-100 | 24-47-65-82-100 | 20-40-60-800-100 | 14-29-43-62-81-100 | 17-33-50-67-83-100 |
| REFRIGERANT | | | | | | | | | | | |
| Type | | R410A | | | | | | | | | |
| COMPRESSOR | | | | | | | | | | | |
| Number | | 3 | 3 | 3 | 3 | 4 | 4 | 5 | 5 | 6 | 6 |
| Type | | Scroll | | | | | | | | | |
| N° of loading stages | | 0/100 | 0/100 | 0/100 | 0/100 | 0/100 | 0/100 | 0/100 | 0/100 | 0/100 | 0/100 |
| EVAPORATOR | | | | | | | | | | | |
| Number | | 1 | 1 | 1 | 1 | 1 | 1 | 1 | 1 | 1 | 1 |
| Type | | Plate | | | | | | | | | |
| Water flow cooling | m³/h | 32.2 | 36.7 | 39.5 | 42.0 | 48.6 | 55.9 | 63.9 | 70.6 | 77.9 | 85.0 |
| Water pressure drop cooling | kPa | 31 | 40 | 46 | 21 | 28 | 36 | 28 | 34 | 32 | 38 |
| Water flow heating | m³/h | 42.6 | 48.0 | 52.1 | 55.4 | 63.6 | 73.8 | 81.8 | 92.6 | 100.6 | 112.9 |
| Water pressure drop heating | kPa | 53 | 67 | 79 | 36 | 47 | 62 | 45 | 57 | 53 | 66 |
| Water volume | l | 14 | 14 | 14 | 24 | 24 | 24 | 32 | 32 | 39 | 39 |
| Antifreeze Heater | W | 130 | 130 | 130 | 130 | 130 | 130 | 130 | 130 | 130 | 130 |
| AIR COOLED CONDENSER | | | | | | | | | | | |
| Number of coils | | 5 | 5 | 6 | 6 | 7 | 8 | 9 | 10 | 11 | 12 |
| Total coil face area per coil | m² | 2.4 | 2.4 | 2.4 | 2.4 | 2.4 | 2.4 | 2.4 | 2.4 | 2.4 | 2.4 |
| FANS | | | | | | | | | | | |
| Number of fans | | 5 | 5 | 6 | 6 | 7 | 8 | 9 | 10 | 11 | 12 |
| Nominal speed | rpm | 550 | 550 | 550 | 550 | 550 | 550 | 550 | 550 | 550 | 550 |
| Total airflow | m³/h | 67.500 | 67.500 | 81.000 | 81.000 | 94.500 | 108.000 | 121.500 | 135.000 | 148.500 | 162.000 |
| Total input power | kW | 4.5 | 4.5 | 5.4 | 5.4 | 6.3 | 7.2 | 8.1 | 9.0 | 9.9 | 10.8 |
| WATER CONNECTIONS (EVAPORATOR) | | | | | | | | | | | |
| Type | | Male GAS Threaded | | | | Victaulic | | | | | |
| Inlet Diameter | inch | 3" | 3" | 3" | 3" | 4" | 4" | 4" | 4" | 5" | 5" |
| Outlet Diameter | inch | 3" | 3" | 3" | 3" | 4" | 4" | 4" | 4" | 5" | 5" |
| WATER CONNECTIONS (DESUPERHEATER) | | | | | | | | | | | |
| Type | | Male GAS Threaded | | | | | | | | | |
| Inlet Diameter | inch | 1" | | | | | | | | | |
| Outlet Diameter | inch | 1" | | | | | | | | | |
| WEIGHT | | | | | | | | | | | |
| Shipping | kg | 1.934 | 1.935 | 2.041 | 2.098 | 2.509 | 2.634 | 3.151 | 3.278 | 3.718 | 3.829 |
| Operating | kg | 1.948 | 1.949 | 2.055 | 2.122 | 2.534 | 2.659 | 3.189 | 3.316 | 3.762 | 3.873 |
| DIMENSIONS | | | | | | | | | | | |
| Length | mm | 3.500 | 3.500 | 3.500 | 3.500 | 4.550 | 4.550 | 5.600 | 5.600 | 6.650 | 6.650 |
| Width | mm | 2.150 | 2.150 | 2.150 | 2.150 | 2.150 | 2.150 | 2.150 | 2.150 | 2.150 | 2.150 |
| Height | mm | 2.600 | 2.600 | 2.600 | 2.600 | 2.600 | 2.600 | 2.600 | 2.600 | 2.600 | 2.600 |

8 - Technical Data (continued)

| SyScroll Air TR | | 240 | 270 | 290 | 320 | 360 | 420 | 470 | 540 | 590 | 660 |
|---|---------|----------------------|-----------|-----------|-----------|--------------|--------------|-----------------|------------------|--------------------|--------------------|
| Power supply | V/ph/Hz | 400 (± 10%) / 3 / 50 | | | | | | | | | |
| Total capacity steps | % | 31-62-100 | 33-67-100 | 30-60-100 | 27-64-100 | 23-46-69-100 | 25-50-75-100 | 24-47-65-82-100 | 20-40-60-800-100 | 14-29-43-62-81-100 | 17-33-50-67-83-100 |
| REFRIGERANT | | | | | | | | | | | |
| Tipo | | R410A | | | | | | | | | |
| COMPRESSOR | | | | | | | | | | | |
| Number | | 3 | 3 | 3 | 3 | 4 | 4 | 5 | 5 | 6 | 6 |
| Type | | Scroll | | | | | | | | | |
| N° of loading stages | | 0/100 | 0/100 | 0/100 | 0/100 | 0/100 | 0/100 | 0/100 | 0/100 | 0/100 | 0/100 |
| EVAPORATOR | | | | | | | | | | | |
| Number | | 1 | 1 | 1 | 1 | 1 | 1 | 1 | 1 | 1 | 1 |
| Type | | Plate | | | | | | | | | |
| Water flow | m³/h | 40.4 | 46.0 | 48.5 | 55.4 | 63.1 | 71.5 | 82.0 | 92.4 | 103.0 | 113.9 |
| Water pressure | kPa | 48 | 62 | 68 | 36 | 46 | 58 | 45 | 57 | 55 | 67 |
| Water volume | l | 14 | 14 | 14 | 24 | 24 | 24 | 32 | 32 | 39 | 39 |
| Tipo Connessioni | | Male GAS Threaded | | | | | Victaulic | | | | |
| Inlet Diameter/Diametro uscita | pollici | 3" | 3" | 3" | 3" | 4" | 4" | 4" | 4" | 5" | 5" |
| CONDENSATORE DI RECUPERO | | | | | | | | | | | |
| Numero | | 1 | 1 | 1 | 1 | 1 | 1 | 1 | 1 | 1 | 1 |
| Type | | Plate | | | | | | | | | |
| Portata acqua | m³/h | 53.5 | 61.4 | 65.2 | 72.3 | 82.6 | 94.5 | 106.4 | 120.7 | 132.9 | 147.6 |
| Perdite di carico | kPa | 83 | 108 | 121 | 59 | 77 | 99 | 74 | 95 | 91 | 111 |
| Volume acqua | l | 14 | 14 | 14 | 24 | 24 | 24 | 32 | 32 | 39 | 39 |
| Tipo Connessioni | | Male GAS Threaded | | | | | Victaulic | | | | |
| Diametro ingresso/Outlet Diameter | inch | 3" | 3" | 3" | 3" | 4" | 4" | 4" | 4" | 5" | 5" |
| CONNESSIONI IDRAULICHE (EVAPORATORE) | | | | | | | | | | | |
| Type | | Male GAS Threaded | | | | | Victaulic | | | | |
| Inlet Diameter | inch | 3" | 3" | 3" | 3" | 4" | 4" | 4" | 4" | 5" | 5" |
| Outlet Diameter | inch | 3" | 3" | 3" | 3" | 4" | 4" | 4" | 4" | 5" | 5" |
| WEIGHT | | | | | | | | | | | |
| Shipping | kg | 1.918 | 1.919 | 2.011 | 2.111 | 2.506 | 2.616 | 3.143 | 3.256 | 3.705 | 9.801 |
| Operating | kg | 1.946 | 1.947 | 2.039 | 2.160 | 2.554 | 2.665 | 3.218 | 3.331 | 3.793 | 9.889 |
| DIMENSIONS | | | | | | | | | | | |
| Length | mm | 3.500 | 3.500 | 3.500 | 3.500 | 4.550 | 4.550 | 5.600 | 5.600 | 6.650 | 6.650 |
| Width | mm | 2.150 | 2.150 | 2.150 | 2.150 | 2.150 | 2.150 | 2.150 | 2.150 | 2.150 | 2.150 |
| Height | mm | 2.600 | 2.600 | 2.600 | 2.600 | 2.600 | 2.600 | 2.600 | 2.600 | 2.600 | 2.600 |

8 - Technical Data (continued)

| SyScroll Air RE_ | | 240 | 270 | 290 | 320 | 360 | 420 | 470 | 540 | 590 | 660 |
|-----------------------------|------|--------------------|--------------------|--------------------|--------------------|--------------------|------------|--------------------|--------------------|------------|------------|
| Refrigerant In connections | inch | 1 5/8" - 2 1/8" | 1 5/8" - 2 1/8" | 1 5/8" - 2 1/8" | 1 5/8" - 2 1/8" | 2 1/8" | 2 1/8" | 2 1/8" - 2 5/8" | 2 1/8" - 2 5/8" | 2 5/8" | 2 5/8" |
| Refrigerant Out connections | inch | 7/8" - 1 1/8" | 7/8" - 1 1/8" | 7/8" - 1 3/8" | 7/8" - 1 3/8" | 1 1/8" - 1 3/8" | 1 3/8" | 1 3/8" | 1 3/8" | 1 3/8" | 1 3/8" |
| SyScroll Air RE_L | | | | | | | | | | | |
| Refrigerant In connections | inch | 1 5/8" - 2 1/8" | 1 5/8" - 2 1/8" | 1 5/8" - 2 1/8" | 1 5/8" - 2 1/8" | 2 1/8" | 2 1/8" | 2 1/8" - 2 5/8" | 2 1/8" - 2 5/8" | 2 5/8" | 2 5/8" |
| Refrigerant Out connections | inch | 7/8" - 1 1/8" | 7/8" - 1 1/8" | 7/8" - 1 3/8" | 7/8" - 1 3/8" | 1 1/8" - 1 3/8" | 1 3/8" | 1 3/8" | 1 3/8" | 1 3/8" | 1 3/8" |
| SyScroll Air RE_S | | | | | | | | | | | |
| Refrigerant In connections | inch | 1 5/8" - 2 1/8" | 1 5/8" - 2 1/8" | 1 5/8" - 2 1/8" | 1 5/8" - 2 1/8" | 2 1/8" | 2 1/8" | 2 1/8" - 2 5/8" | 2 1/8" - 2 5/8" | 2 5/8" | 2 5/8" |
| Refrigerant Out connections | inch | 7/8" - 1 1/8" | 7/8" - 1 1/8" | 7/8" - 1 3/8" | 7/8" - 1 3/8" | 1 1/8" - 1 3/8" | 1 3/8" | 1 3/8" | 1 3/8" | 1 3/8" | 1 3/8" |
| WEIGHT | | | | | | | | | | | |
| Shipping | kg | 1.670 | 1.671 | 1.790 | 1.802 | 2.185 | 2.296 | 2.747 | 2.860 | 3.237 | 3.333 |
| DIMENSIONS | | | | | | | | | | | |
| Length | mm | 3.500 | 3.500 | 3.500 | 3.500 | 4.550 | 4.550 | 5.600 | 5.600 | 6.650 | 6.650 |
| Width | mm | 2.150 | 2.150 | 2.150 | 2.150 | 2.150 | 2.150 | 2.150 | 2.150 | 2.150 | 2.150 |
| Height | mm | 2.600 | 2.600 | 2.600 | 2.600 | 2.600 | 2.600 | 2.600 | 2.600 | 2.600 | 2.600 |

8 - Technical Data (continued)

8.3 Unit electrical data

| SyScroll Air - | | 240 | 270 | 290 | 320 | 360 | 420 | 470 | 540 | 590 | 660 |
|---|-----------------|----------------------|------------|------------|------------|------------|------------|------------|------------|------------|------------|
| Rated voltage | V/ph/Hz | 400 (± 10%) / 3 / 50 | | | | | | | | | |
| Max. absorbed power | kW | 114 | 128 | 140 | 150 | 181 | 213 | 217 | 246 | 266 | 295 |
| Rated Current | A | 131 | 150 | 165 | 175 | 212 | 248 | 280 | 318 | 343 | 381 |
| Max. current FLA | A | 193 | 219 | 238 | 253 | 308 | 357 | 398 | 454 | 489 | 545 |
| Max. start-up current LRA | A | 414 | 440 | 455 | 470 | 525 | 574 | 796 | 851 | 887 | 942 |
| External fuses | A | 250 | 250 | 315 | 315 | 400 | 400 | 500 | 500 | 630 | 630 |
| Max. cable section (*) | mm ² | 120 | 120 | 185 | 185 | 240 | 240 | 2x185 | 2x185 | 2x185 | 2x185 |
| Exchanger resistance - Rated voltage | V/ph/Hz | 230 (± 10%) / 1 / 50 | | | | | | | | | |
| Exchanger resistance - Max. absorbed power | W | 130 | | | | | | | | | |

| SyScroll Air L_S | | 240 | 270 | 290 | 320 | 360 | 420 | 470 | 540 | 590 | 660 |
|---|-----------------|----------------------|------------|------------|------------|------------|------------|------------|------------|------------|------------|
| Rated voltage | V/ph/Hz | 400 (± 10%) / 3 / 50 | | | | | | | | | |
| Max. absorbed power | kW | 109 | 123 | 134 | 144 | 174 | 205 | 209 | 237 | 256 | 284 |
| Rated Current | A | 121 | 140 | 153 | 164 | 198 | 232 | 262 | 299 | 322 | 358 |
| Max. current FLA | A | 183 | 209 | 226 | 241 | 294 | 342 | 381 | 435 | 468 | 522 |
| Max. start-up current LRA | A | 404 | 430 | 443 | 458 | 511 | 559 | 779 | 832 | 866 | 919 |
| External fuses | A | 250 | 250 | 315 | 315 | 400 | 400 | 500 | 500 | 630 | 630 |
| Max. cable section (*) | mm ² | 120 | 120 | 185 | 185 | 240 | 240 | 2x185 | 2x185 | 2x185 | 2x185 |
| Exchanger resistance - Rated voltage | V/ph/Hz | 230 (± 10%) / 1 / 50 | | | | | | | | | |
| Exchanger resistance - Max. absorbed power | W | 130 | | | | | | | | | |

| SyScroll Air HT-HPF | | 240 | 270 | 290 | 320 | 360 | 420 | 470 | 540 | 590 | 660 |
|---|-----------------|----------------------|------------|------------|------------|------------|------------|------------|------------|------------|------------|
| Rated voltage | V/ph/Hz | 400 (± 10%) / 3 / 50 | | | | | | | | | |
| Max. absorbed power | kW | 119 | 133 | 146 | 156 | 188 | 221 | 226 | 256 | 277 | 307 |
| Rated Current | A | 134 | 153 | 169 | 179 | 217 | 253 | 286 | 325 | 351 | 390 |
| Max. current FLA | A | 196 | 222 | 242 | 257 | 313 | 362 | 405 | 461 | 497 | 553 |
| Max. start-up current LRA | A | 417 | 443 | 459 | 474 | 530 | 579 | 802 | 858 | 894 | 951 |
| External fuses | A | 250 | 250 | 315 | 315 | 400 | 400 | 500 | 500 | 630 | 630 |
| Max. cable section (*) | mm ² | 120 | 120 | 185 | 185 | 240 | 240 | 2x185 | 2x185 | 2x185 | 2x185 |
| Exchanger resistance - Rated voltage | V/ph/Hz | 230 (± 10%) / 1 / 50 | | | | | | | | | |
| Exchanger resistance - Max. absorbed power | W | 130 | | | | | | | | | |

(*) The dimensioning of the unit's power cables is the responsibility of the installer, who shall consider: the rating, the maximum working temperature in the room, the type of insulation and the cable laying, the maximum length of the power supply line.

Pump electrical data

| Low Pressure | | 240 | 270 | 290 | 320 | 360 | 420 | 470 | 540 | 590 | 660 |
|---------------------|---------|----------------------|------------|------------|------------|------------|------------|------------|------------|------------|------------|
| Rated voltage | V/ph/Hz | 400 (± 10%) / 3 / 50 | | | | | | | | | |
| Max. absorbed power | kW | 4.0 | 4.0 | 4.0 | 4.0 | 7.5 | 7.5 | 7.5 | 11.0 | 11.0 | 11.0 |
| Max. current FLA | A | 7.63 | 7.63 | 7.63 | 7.63 | 14.00 | 14.00 | 14.00 | 20.30 | 20.30 | 20.30 |

| High Pressure | | 240 | 270 | 290 | 320 | 360 | 420 | 470 | 540 | 590 | 660 |
|----------------------|---------|----------------------|------------|------------|------------|------------|------------|------------|------------|------------|------------|
| Rated voltage | V/ph/Hz | 400 (± 10%) / 3 / 50 | | | | | | | | | |
| Max. absorbed power | kW | 5.5 | 5.5 | 7.5 | 7.5 | 11.0 | 11.0 | 11.0 | 15.0 | 15.0 | 15.0 |
| Max. current FLA | A | 10.40 | 10.40 | 14.00 | 14.00 | 20.30 | 20.30 | 20.30 | 26.00 | 26.00 | 26.00 |

8 - Technical Data (continued)

Compressors electrical data

| Syscroll Air | 240 | 270 | 290 | 320 | 360 | 420 | 470 | 540 | 590 | 660 | |
|---------------------|-------------|----------------|------|------|------|------|------|------|-------|------|------|
| Number | 3 | 3 | 3 | 3 | 4 | 4 | 5 | 5 | 6 | 6 | |
| Rated power | kW | 26.7 | 26.7 | 26.7 | 26.7 | 26.7 | 32.7 | 32.5 | 32.5 | 25.6 | 32.5 |
| | | 21.1 | 26.7 | 26.7 | 32.7 | 26.7 | 32.7 | 32.5 | 32.50 | 25.6 | 32.5 |
| | | 21.1 | 26.7 | 32.7 | 32.7 | 26.7 | 32.7 | 25.6 | 32.5 | 25.6 | 32.5 |
| | | | | | | 32.7 | 32.7 | 25.6 | 32.5 | 32.5 | 32.5 |
| | | | | | | | | 25.6 | 32.5 | 32.5 | 32.5 |
| Max. absorbed power | kW | 39.0 | 39.0 | 39.0 | 39.0 | 39.0 | 49.0 | 45.0 | 45.0 | 36.1 | 45.0 |
| | | 32.0 | 39.0 | 39.0 | 49.0 | 39.0 | 49.0 | 45.0 | 45.0 | 36.1 | 45.0 |
| | | 32.0 | 39.0 | 49.0 | 49.0 | 39.0 | 49.0 | 36.1 | 45.0 | 36.1 | 45.0 |
| | | | | | | 49.0 | 49.0 | 36.1 | 45.0 | 45.0 | 45.0 |
| | | | | | | | | 36.1 | 45.0 | 45.0 | 45.0 |
| Rated current | A | 43.1 | 43.1 | 43.1 | 43.1 | 43.1 | 53.7 | 55.3 | 55.3 | 44.0 | 55.3 |
| | | 33.6 | 43.1 | 43.1 | 53.7 | 43.1 | 53.7 | 55.3 | 55.3 | 44.0 | 55.3 |
| | | 33.6 | 43.1 | 53.7 | 53.7 | 43.1 | 53.7 | 44.0 | 55.3 | 44.0 | 55.3 |
| | | | | | | 53.7 | 53.7 | 44.0 | 55.3 | 55.3 | 55.3 |
| | | | | | | | | 44.0 | 55.3 | 55.3 | 55.3 |
| Max current | A | 66.0 | 66.0 | 66.0 | 66.0 | 66.0 | 81.0 | 82.6 | 82.6 | 65.4 | 82.6 |
| | | 53.0 | 66.0 | 66.0 | 81.0 | 66.0 | 81.0 | 82.6 | 82.6 | 65.4 | 82.6 |
| | | 53.0 | 66.0 | 81.0 | 81.0 | 66.0 | 81.0 | 65.4 | 82.6 | 65.4 | 82.6 |
| | | | | | | 81.0 | 81.0 | 65.4 | 82.6 | 82.6 | 82.6 |
| | | | | | | | | 65.4 | 82.6 | 82.6 | 82.6 |
| Oil pan resistor | V/ph/Hz - W | 230/1/50 - 150 | | | | | | | | | |

Fans electrical data

| Syscroll Air - | 240 | 270 | 290 | 320 | 360 | 420 | 470 | 540 | 590 | 660 |
|----------------|--|-----|-----|-----|-----|-----|-----|-----|-----|-----|
| Rated voltage | V/ph/Hz 400 (± 10%) / 3 / 50 | | | | | | | | | |
| Number | 5 | 5 | 6 | 6 | 7 | 8 | 9 | 10 | 11 | 12 |
| Rated power | kW 2.1 2.1 2.1 2.1 2.1 2.1 2.1 2.1 2.1 2.1 | | | | | | | | | |
| Rated current | A 4.1 4.1 4.1 4.1 4.1 4.1 4.1 4.1 4.1 4.1 | | | | | | | | | |

| Syscroll Air L_S | 240 | 270 | 290 | 320 | 360 | 420 | 470 | 540 | 590 | 660 |
|------------------|--|-----|-----|-----|-----|-----|-----|-----|-----|-----|
| Rated voltage | V/ph/Hz 400 (± 10%) / 3 / 50 | | | | | | | | | |
| Number | 5 | 5 | 6 | 6 | 7 | 8 | 9 | 10 | 11 | 12 |
| Rated power | kW 1.15 1.15 1.15 1.15 1.15 1.15 1.15 1.15 1.15 1.15 | | | | | | | | | |
| Rated current | A 2.2 2.2 2.2 2.2 2.2 2.2 2.2 2.2 2.2 2.2 | | | | | | | | | |

| Syscroll Air HT_HPF | 240 | 270 | 290 | 320 | 360 | 420 | 470 | 540 | 590 | 660 |
|---------------------|--|-----|-----|-----|-----|-----|-----|-----|-----|-----|
| Rated voltage | V/ph/Hz 400 (± 10%) / 3 / 50 | | | | | | | | | |
| Number | 5 | 5 | 6 | 6 | 7 | 8 | 9 | 10 | 11 | 12 |
| Rated power | kW 3.1 3.1 3.1 3.1 3.1 3.1 3.1 3.1 3.1 3.1 | | | | | | | | | |
| Rated current | A 4.8 4.8 4.8 4.8 4.8 4.8 4.8 4.8 4.8 4.8 | | | | | | | | | |

8 - Technical Data (continued)

8.4 Hydraulic features

Evaporator Water Pressure Drop Curves - SyScroll Air CO

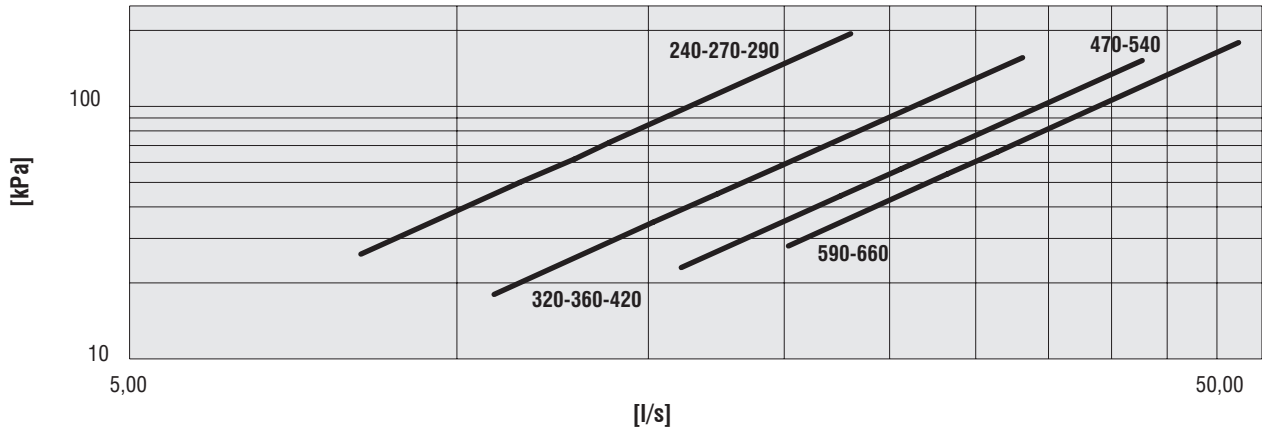

Evaporator Water Pressure Drop Curves - SyScroll Air HP

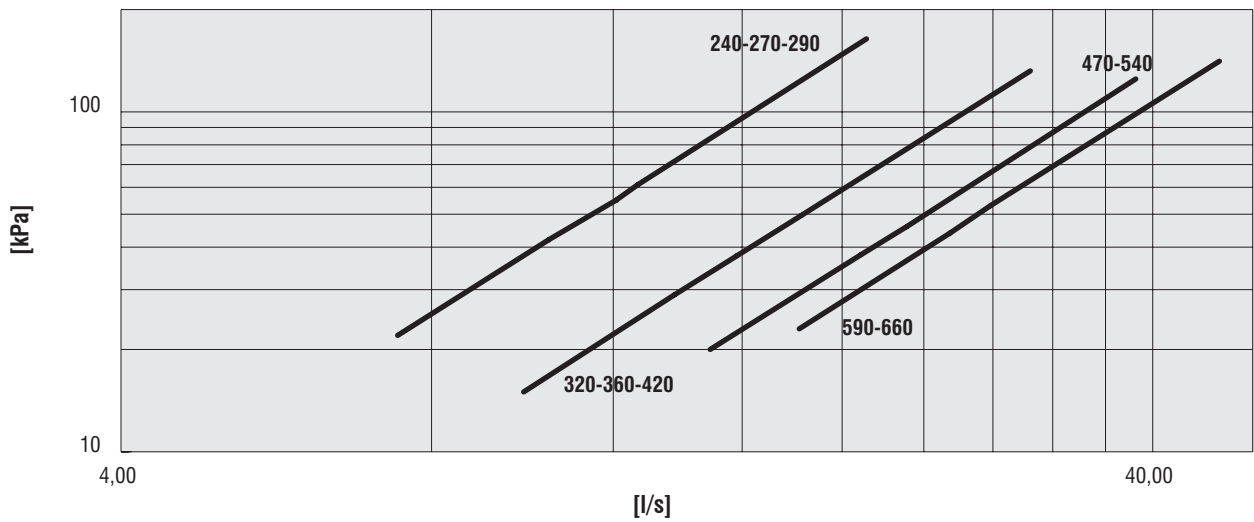

Condenser Water Pressure Drop Curves - SyScroll Air HP

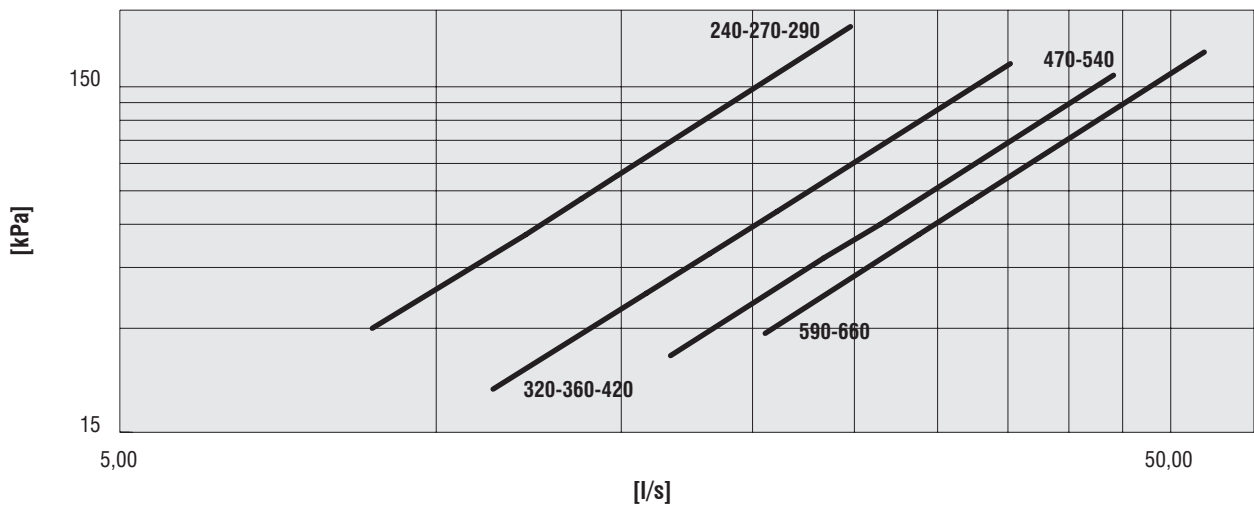

8 - Technical Data (continued)

Condenser Water Pressure Drop Curves - SyScroll Air TR

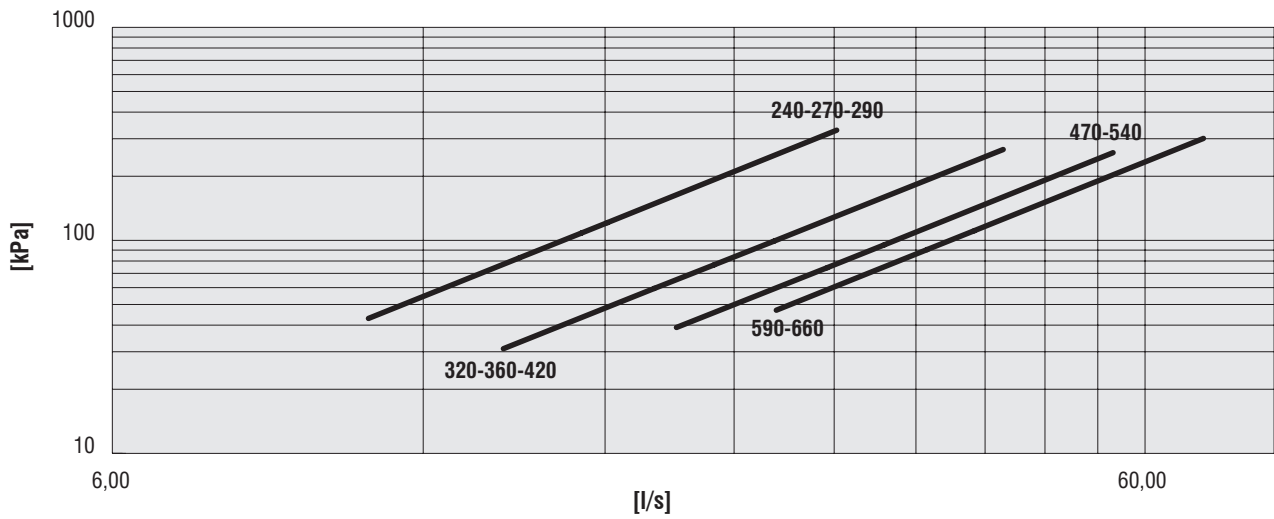

Desuperheater pressure drop

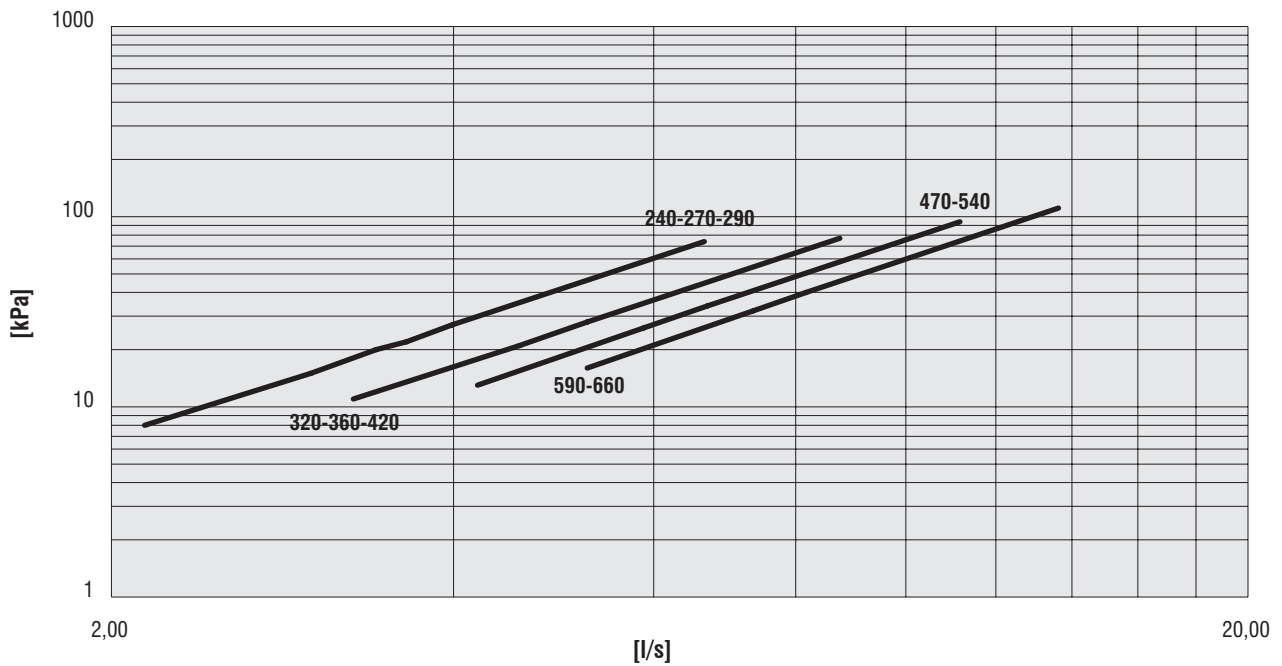

8 - Technical Data (continued)

Available pressure head - SYSCROLL 240-270 Air CO 2P+T

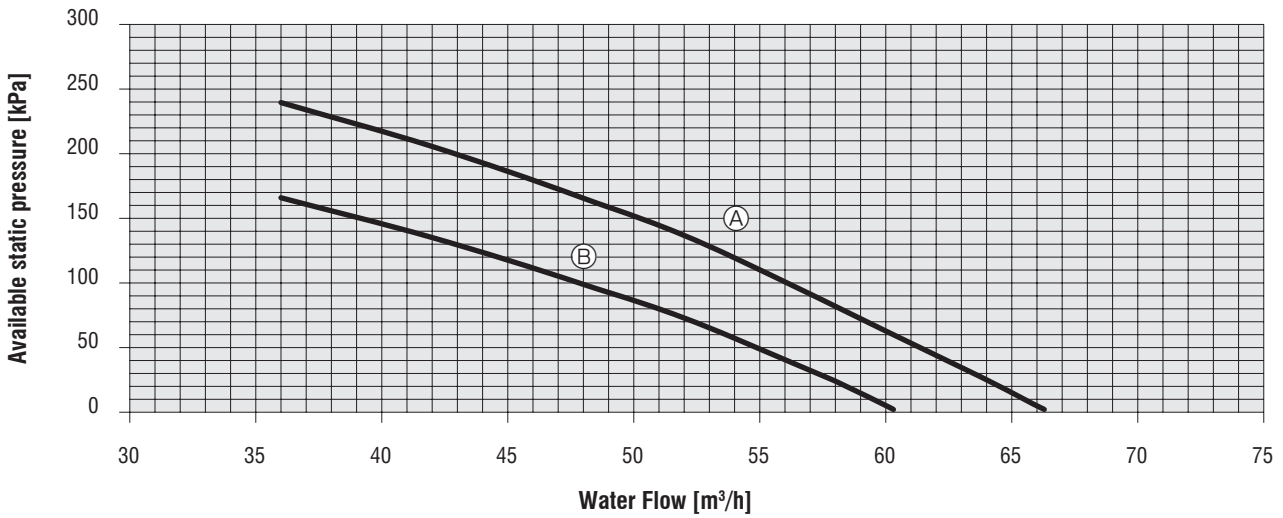

Available pressure head - SYSCROLL 290 Air CO 2P+T

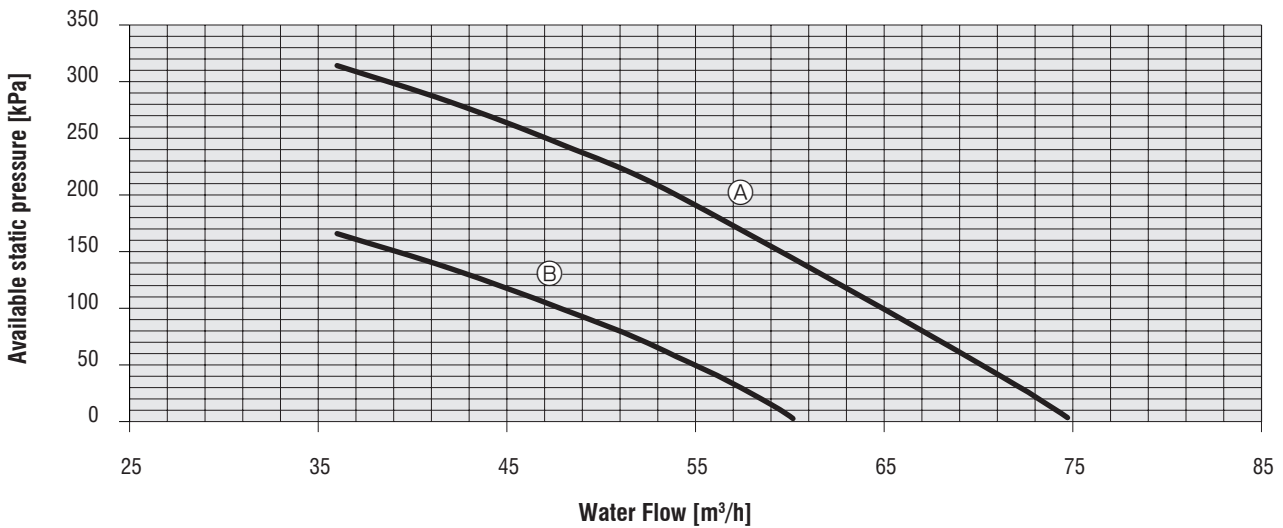

Available pressure head - SYSCROLL 320 Air CO 2P+T

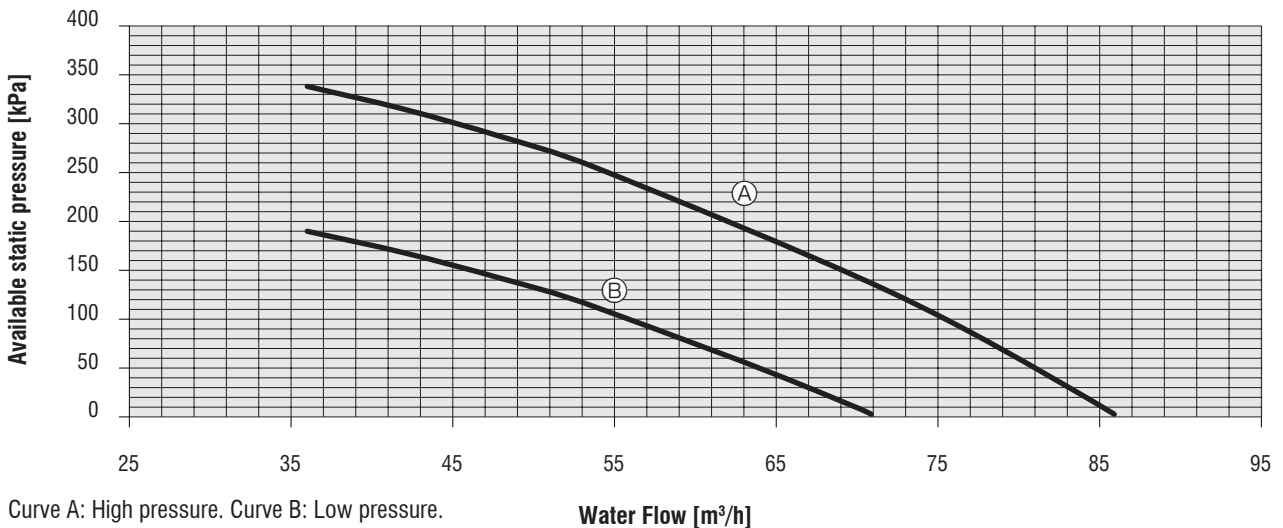

Curve A: High pressure. Curve B: Low pressure.

8 - Technical Data (continued)

Available pressure head - SYSCROLL 360-420 Air CO 2P+T

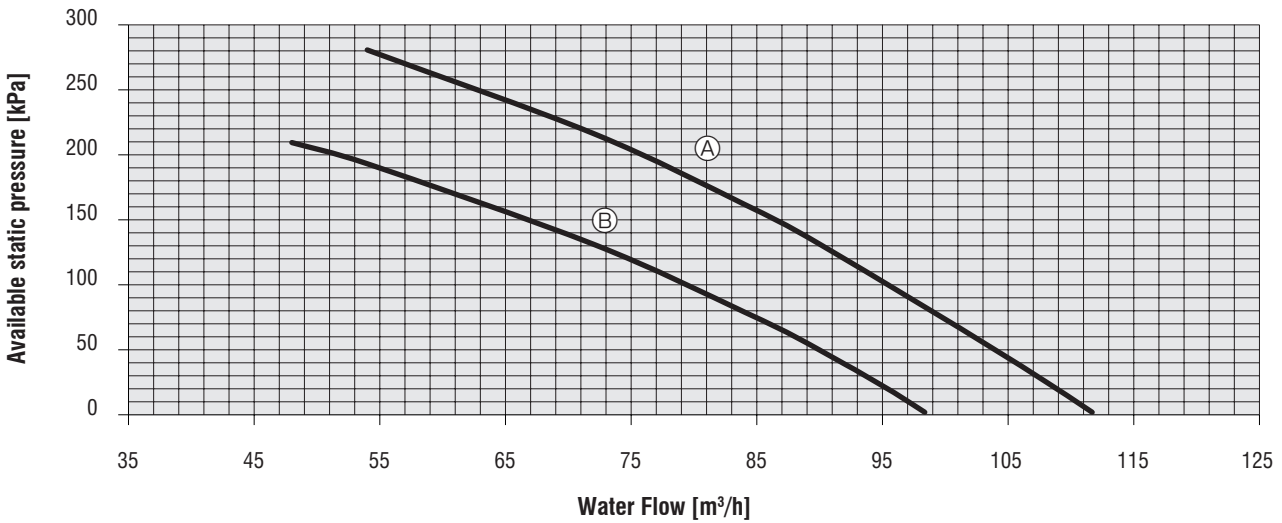

Available pressure head - SYSCROLL 470 Air CO 2P+T

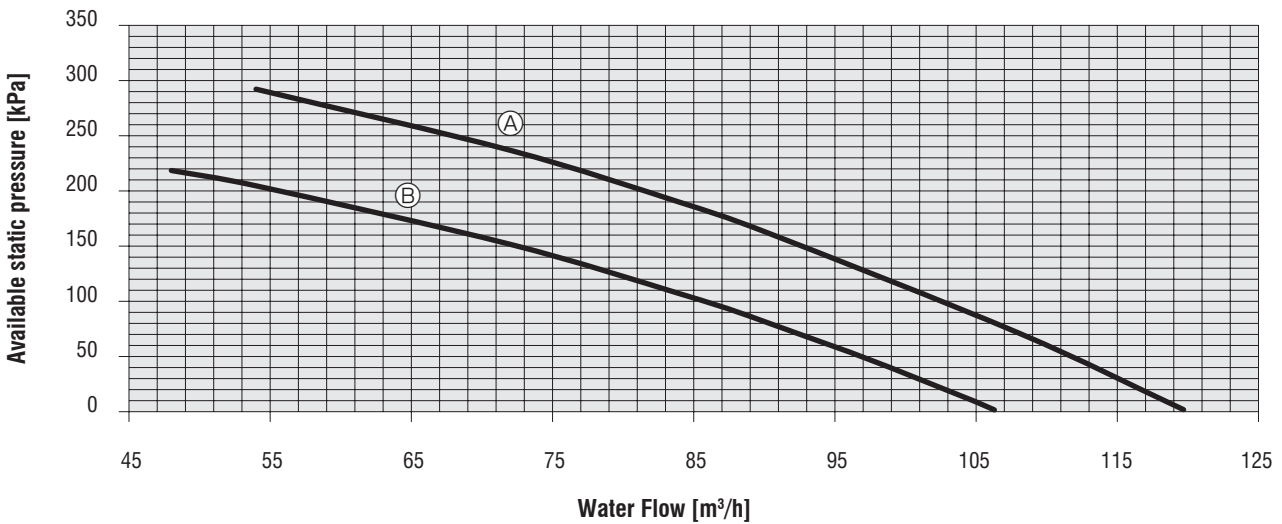

Available pressure head - SYSCROLL 470 Air CO 2P+T

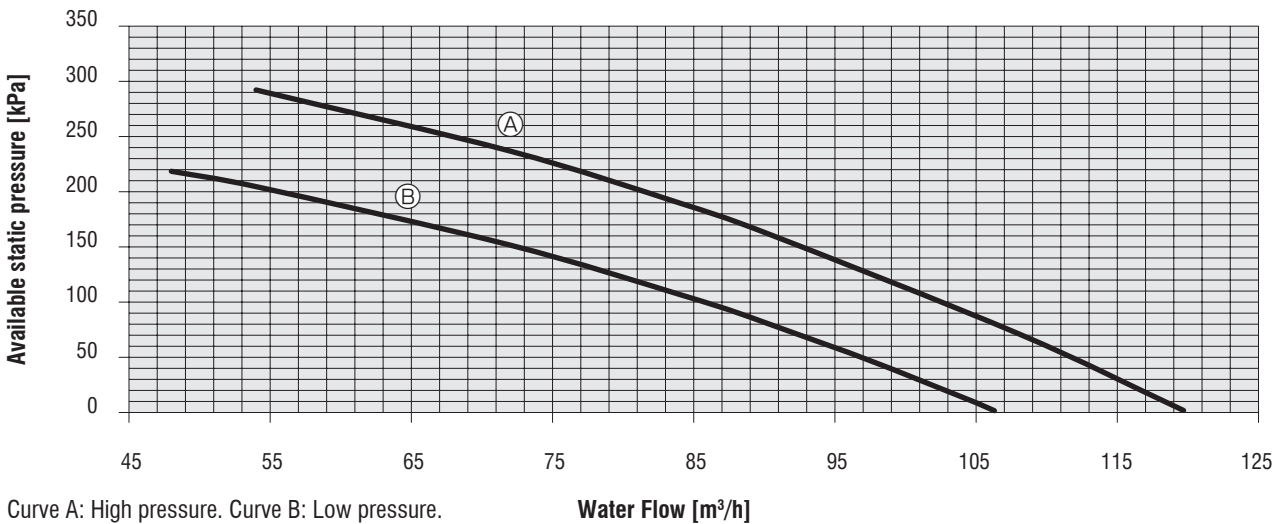

Curve A: High pressure. Curve B: Low pressure.

8 - Technical Data (continued)

Available pressure head - SYSCROLL 540 Air CO 2P+T

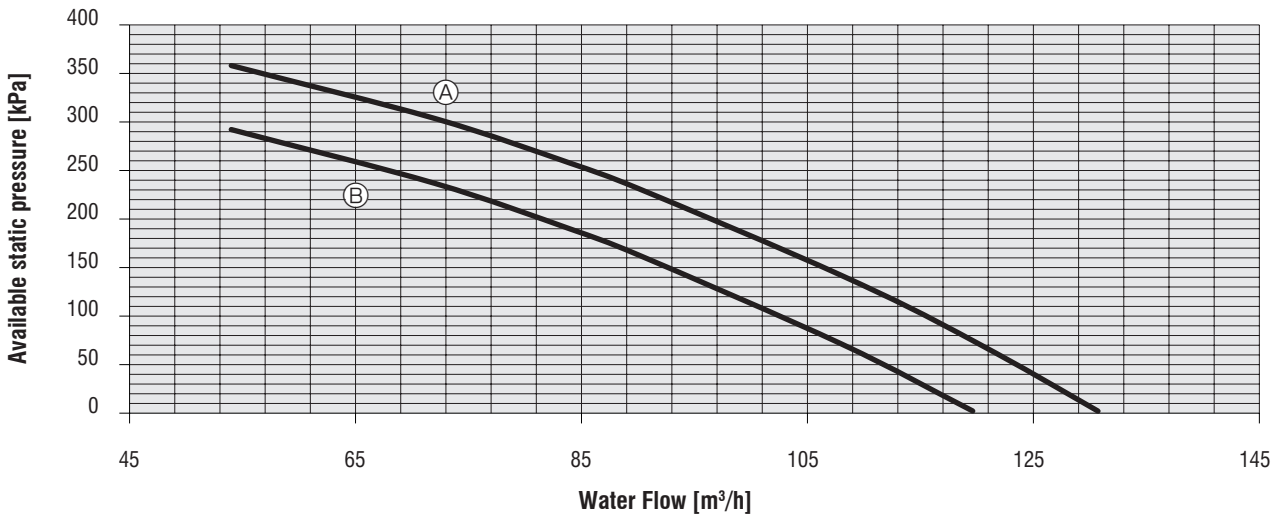

Available pressure head - SYSCROLL 590 -660 Air CO 2P+T

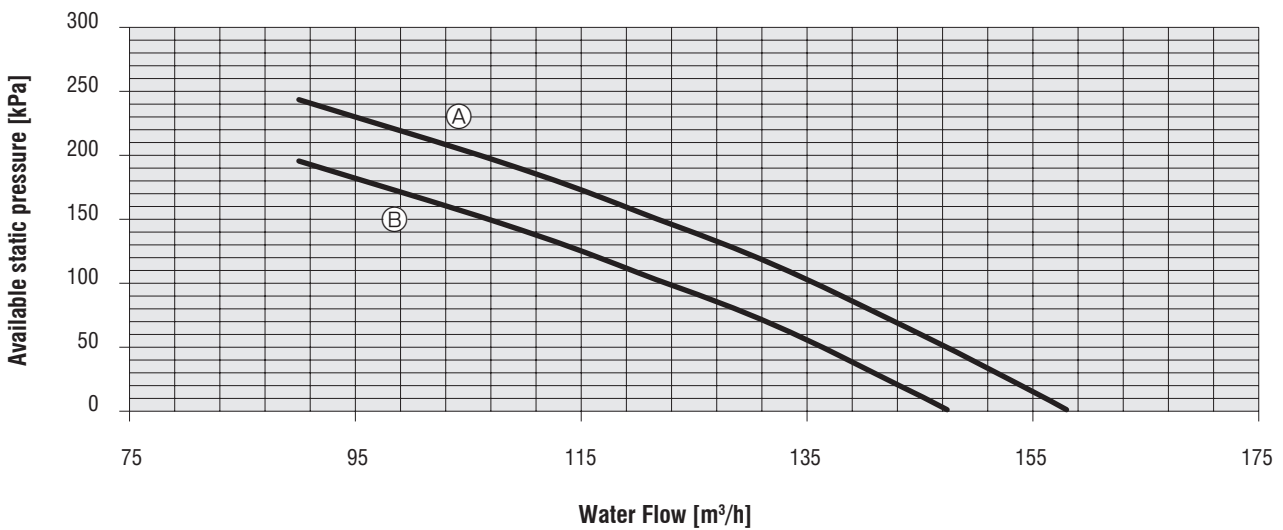

Curve A: High pressure. Curve B: Low pressure.

8 - Technical Data (continued)

8.5 Position of shock adsorbers and weight distribution on supports

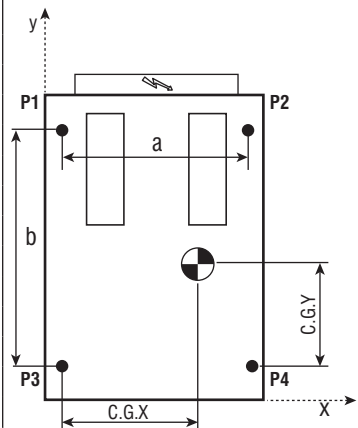

| SYS CO | Weight distribution (kg) | | | | Operating weight (kg) | Shipping weight (kg) | P1-P4 coordinates | | CG coordinates | |
|-------------|--------------------------|-----|-----|-----|-----------------------|----------------------|-------------------|--------|----------------|--------|
| | P1 | P2 | P3 | P4 | | | a (mm) | b (mm) | x (mm) | y (mm) |
| 240 | 636 | 575 | 318 | 257 | 1786 | 1772 | 2070 | 2056 | 1002 | 1979 |
| 270 | 637 | 576 | 318 | 257 | 1787 | 1773 | 2070 | 2056 | 1002 | 1979 |
| 290 | 663 | 601 | 338 | 276 | 1879 | 1865 | 2070 | 2056 | 1005 | 1967 |
| 320 | 672 | 609 | 364 | 300 | 1945 | 1921 | 2070 | 2056 | 1006 | 1938 |
| 360 | 800 | 798 | 367 | 365 | 2330 | 2306 | 2070 | 3060 | 1072 | 2682 |
| 420 | 837 | 837 | 383 | 383 | 2441 | 2417 | 2070 | 3060 | 1073 | 2683 |
| 240 1P-SP | 626 | 581 | 344 | 300 | 1851 | 1837 | 2070 | 2056 | 1023 | 1925 |
| 270 1P-SP | 626 | 582 | 345 | 300 | 1852 | 1838 | 2070 | 2056 | 1023 | 1925 |
| 290 1P-SP | 653 | 607 | 365 | 319 | 1944 | 1930 | 2070 | 2056 | 1024 | 1916 |
| 320 1P-SP | 662 | 615 | 390 | 343 | 2011 | 1986 | 2070 | 2056 | 1025 | 1890 |
| 360 1P-SP | 795 | 814 | 400 | 418 | 2427 | 2403 | 2070 | 3060 | 1089 | 2612 |
| 420 1P-SP | 825 | 854 | 424 | 454 | 2558 | 2533 | 2070 | 3060 | 1097 | 2593 |
| 240 2P-SP | 615 | 587 | 364 | 335 | 1901 | 1887 | 2070 | 2056 | 1042 | 1884 |
| 270 2P-SP | 616 | 587 | 364 | 335 | 1902 | 1888 | 2070 | 2056 | 1042 | 1884 |
| 290 2P-SP | 642 | 613 | 384 | 355 | 1994 | 1980 | 2070 | 2056 | 1042 | 1878 |
| 320 2P-SP | 652 | 621 | 410 | 379 | 2061 | 2036 | 2070 | 2056 | 1042 | 1853 |
| 360 2P-SP | 771 | 816 | 433 | 478 | 2498 | 2474 | 2070 | 3060 | 1110 | 2529 |
| 420 2P-SP | 807 | 866 | 458 | 517 | 2649 | 2624 | 2070 | 3060 | 1119 | 2517 |
| 240 1P-SP T | 719 | 513 | 722 | 516 | 2471 | 1957 | 2070 | 2056 | 901 | 1610 |
| 270 1P-SP T | 720 | 514 | 723 | 517 | 2472 | 1958 | 2070 | 2056 | 901 | 1610 |
| 290 1P-SP T | 746 | 539 | 743 | 536 | 2564 | 2050 | 2070 | 2056 | 906 | 1614 |
| 320 1P-SP T | 755 | 547 | 768 | 560 | 2631 | 2106 | 2070 | 2056 | 909 | 1602 |
| 360 1P-SP T | 972 | 769 | 875 | 671 | 3287 | 2563 | 2070 | 3060 | 945 | 2205 |
| 420 1P-SP T | 1006 | 810 | 898 | 703 | 3418 | 2693 | 2070 | 3060 | 955 | 2210 |
| 240 2P-SP T | 709 | 519 | 742 | 552 | 2521 | 2007 | 2070 | 2056 | 917 | 1585 |
| 270 2P-SP T | 709 | 519 | 742 | 552 | 2522 | 2008 | 2070 | 2056 | 917 | 1585 |
| 290 2P-SP T | 736 | 545 | 762 | 572 | 2614 | 2100 | 2070 | 2056 | 922 | 1591 |
| 320 2P-SP T | 745 | 553 | 788 | 595 | 2681 | 2156 | 2070 | 2056 | 925 | 1579 |
| 360 2P-SP T | 958 | 778 | 901 | 721 | 3358 | 2634 | 2070 | 3060 | 962 | 2166 |
| 420 2P-SP T | 988 | 822 | 932 | 766 | 3509 | 2784 | 2070 | 3060 | 975 | 2163 |

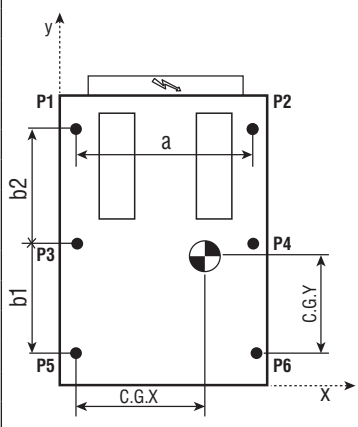

| SYS CO | Weight distribution (kg) | | | | | | Operating weight (kg) | Shipping weight (kg) | P1-P6 coordinates | | | CG coordinates | |
|-------------|--------------------------|-----|-----|-----|------|-----|-----------------------|----------------------|-------------------|---------|---------|----------------|--------|
| | P1 | P2 | P3 | P4 | P5 | P6 | | | a (mm) | b1 (mm) | b2 (mm) | x (mm) | y (mm) |
| 470 | 761 | 718 | 511 | 467 | 260 | 217 | 2934 | 2897 | 2070 | 2056 | 2056 | 989 | 2757 |
| 540 | 783 | 739 | 530 | 486 | 277 | 233 | 3047 | 3009 | 2070 | 2056 | 2056 | 990 | 2739 |
| 590 | 799 | 798 | 606 | 605 | 325 | 324 | 3456 | 3412 | 2070 | 3060 | 2104 | 1034 | 3457 |
| 660 | 818 | 818 | 622 | 622 | 337 | 337 | 3553 | 3509 | 2070 | 3060 | 2104 | 1035 | 3448 |
| 470 1P-SP | 742 | 721 | 519 | 498 | 296 | 274 | 3051 | 2988 | 2070 | 2056 | 2056 | 1013 | 2657 |
| 540 1P-SP | 764 | 745 | 539 | 520 | 314 | 295 | 3178 | 3115 | 2070 | 2056 | 2056 | 1016 | 2638 |
| 590 1P-SP | 780 | 800 | 611 | 631 | 365 | 385 | 3573 | 3503 | 2070 | 3060 | 2104 | 1052 | 3349 |
| 660 1P-SP | 792 | 818 | 627 | 653 | 388 | 414 | 3693 | 3623 | 2070 | 3060 | 2104 | 1057 | 3313 |
| 470 2P-SP | 727 | 723 | 526 | 522 | 325 | 321 | 3142 | 3079 | 2070 | 2056 | 2056 | 1031 | 2582 |
| 540 2P-SP | 748 | 747 | 545 | 544 | 343 | 342 | 3269 | 3206 | 2070 | 2056 | 2056 | 1034 | 2566 |
| 590 2P-SP | 765 | 803 | 614 | 652 | 396 | 434 | 3664 | 3594 | 2070 | 3060 | 2104 | 1067 | 3267 |
| 660 2P-SP | 772 | 821 | 632 | 680 | 427 | 475 | 3807 | 3737 | 2070 | 3060 | 2104 | 1074 | 3216 |
| 470 1P-SP T | 854 | 577 | 847 | 570 | 840 | 563 | 4251 | 3188 | 2070 | 2056 | 2056 | 832 | 2070 |
| 540 1P-SP T | 876 | 601 | 867 | 592 | 858 | 584 | 4378 | 3315 | 2070 | 2056 | 2056 | 840 | 2073 |
| 590 1P-SP T | 875 | 639 | 908 | 673 | 957 | 721 | 4773 | 3703 | 2070 | 3060 | 2104 | 882 | 2652 |
| 660 1P-SP T | 887 | 657 | 925 | 695 | 980 | 750 | 4893 | 3823 | 2070 | 3060 | 2104 | 889 | 2642 |
| 470 2P-SP T | 838 | 579 | 853 | 594 | 868 | 609 | 4342 | 3279 | 2070 | 2056 | 2056 | 850 | 2012 |
| 540 2P-SP T | 860 | 603 | 873 | 617 | 887 | 630 | 4469 | 3406 | 2070 | 2056 | 2056 | 857 | 2017 |
| 590 2P-SP T | 910 | 693 | 940 | 722 | 982 | 764 | 5010 | 3941 | 2070 | 3060 | 2104 | 900 | 2649 |
| 660 2P-SP T | 918 | 711 | 957 | 749 | 1013 | 805 | 5153 | 4083 | 2070 | 3060 | 2104 | 910 | 2628 |

8 - Technical Data (continued)

| | SYS HP | Weight distribution (kg) | | | | Operating weight (kg) | Shipping weight (kg) | P1-P4 coordinates | | CG coordinates | |
|--|--------------------|--------------------------|-----|-----|-----|-----------------------|----------------------|-------------------|--------|----------------|--------|
| | | P1 | P2 | P3 | P4 | | | a (mm) | b (mm) | x (mm) | y (mm) |
| | 240 | 724 | 649 | 325 | 250 | 1948 | 1934 | 2070 | 2056 | 1007 | 1985 |
| | 270 | 725 | 725 | 725 | 725 | 725 | 725 | 725 | 725 | 725 | 725 |
| | 290 | 758 | 681 | 347 | 270 | 2055 | 2041 | 2070 | 2056 | 1010 | 1975 |
| | 320 | 768 | 689 | 372 | 293 | 2122 | 2098 | 2070 | 2056 | 1010 | 1948 |
| | 360 | 903 | 884 | 383 | 364 | 2534 | 2509 | 2070 | 3060 | 1072 | 2694 |
| | 420 | 946 | 928 | 401 | 383 | 2659 | 2634 | 2070 | 3060 | 1073 | 2693 |
| | 240 1P-SP | 715 | 656 | 351 | 292 | 2014 | 2000 | 2070 | 2056 | 1026 | 1936 |
| | 270 1P-SP | 715 | 656 | 351 | 292 | 2015 | 2001 | 2070 | 2056 | 1026 | 1935 |
| | 290 1P-SP | 748 | 687 | 373 | 312 | 2121 | 2107 | 2070 | 2056 | 1027 | 1928 |
| | 320 1P-SP | 759 | 696 | 398 | 335 | 2187 | 2163 | 2070 | 2056 | 1027 | 1903 |
| | 360 1P-SP | 899 | 900 | 416 | 416 | 2631 | 2606 | 2070 | 3060 | 1087 | 2629 |
| | 420 1P-SP | 935 | 946 | 442 | 453 | 2776 | 2751 | 2070 | 3060 | 1095 | 2610 |
| | 240 2P-SP | 705 | 662 | 370 | 327 | 2064 | 2050 | 2070 | 2056 | 1044 | 1898 |
| | 270 2P-SP | 706 | 662 | 370 | 327 | 2065 | 2051 | 2070 | 2056 | 1044 | 1898 |
| | 290 2P-SP | 739 | 693 | 392 | 347 | 2171 | 2157 | 2070 | 2056 | 1044 | 1892 |
| | 320 2P-SP | 749 | 702 | 417 | 370 | 2237 | 2213 | 2070 | 2056 | 1044 | 1869 |
| | 360 2P-SP | 876 | 903 | 448 | 474 | 2702 | 2677 | 2070 | 3060 | 1107 | 2551 |
| | 420 2P-SP | 918 | 958 | 475 | 515 | 2867 | 2842 | 2070 | 3060 | 1116 | 2539 |
| | 240 1P-SP T | 818 | 593 | 724 | 499 | 2634 | 2120 | 2070 | 2056 | 910 | 1637 |
| | 270 1P-SP T | 818 | 593 | 724 | 499 | 2635 | 2121 | 2070 | 2056 | 910 | 1637 |
| | 290 1P-SP T | 851 | 624 | 746 | 519 | 2741 | 2227 | 2070 | 2056 | 916 | 1643 |
| | 320 1P-SP T | 861 | 633 | 771 | 542 | 2807 | 2283 | 2070 | 2056 | 919 | 1630 |
| | 360 1P-SP T | 1086 | 859 | 886 | 659 | 3491 | 2766 | 2070 | 3060 | 952 | 2241 |
| | 420 1P-SP T | 1126 | 906 | 912 | 692 | 3636 | 2911 | 2070 | 3060 | 962 | 2246 |
| | 240 2P-SP T | 808 | 599 | 743 | 534 | 2684 | 2170 | 2070 | 2056 | 926 | 1614 |
| | 270 2P-SP T | 808 | 599 | 743 | 534 | 2685 | 2171 | 2070 | 2056 | 926 | 1614 |
| | 290 2P-SP T | 841 | 631 | 765 | 554 | 2791 | 2277 | 2070 | 2056 | 931 | 1620 |
| | 320 2P-SP T | 852 | 639 | 790 | 577 | 2857 | 2333 | 2070 | 2056 | 933 | 1609 |
| | 360 2P-SP T | 1073 | 868 | 912 | 708 | 3562 | 2837 | 2070 | 3060 | 968 | 2204 |
| | 420 2P-SP T | 1109 | 918 | 945 | 754 | 3727 | 3002 | 2070 | 3060 | 981 | 2201 |

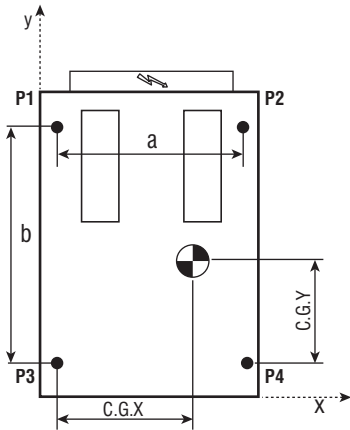

8 - Technical Data (continued)

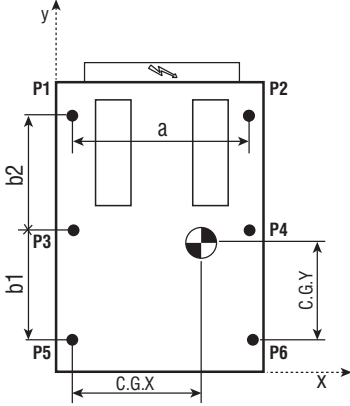
|  | SYS HP | Weight distribution (kg) | | | | | | Operating weight (kg) | Shipping weight (kg) | P1-P6 coordinates | | | CG coordinates | |
|---|--------|--------------------------|-----|-----|------|-----|------|-----------------------|----------------------|-------------------|---------|---------|----------------|--------|
| | | P1 | P2 | P3 | P4 | P5 | P6 | | | a (mm) | b1 (mm) | b2 (mm) | x (mm) | y (mm) |
| | | 470 | 831 | 787 | 554 | 509 | 276 | | | 231 | 3189 | 3151 | 2070 | 2056 |
| 540 | 857 | 811 | 575 | 530 | 294 | 249 | 3316 | 3278 | 2070 | 2056 | 2056 | 992 | 2754 | |
| 590 | 875 | 874 | 660 | 659 | 348 | 346 | 3762 | 3718 | 2070 | 3060 | 2104 | 1034 | 3474 | |
| 660 | 897 | 897 | 679 | 679 | 361 | 361 | 3873 | 3829 | 2070 | 3060 | 2104 | 1035 | 3463 | |
| 470 1P-SP | 813 | 794 | 563 | 544 | 313 | 294 | 3320 | 3257 | 2070 | 2056 | 2056 | 1017 | 2675 | |
| 540 1P-SP | 838 | 818 | 585 | 564 | 332 | 311 | 3447 | 3384 | 2070 | 2056 | 2056 | 1017 | 2660 | |
| 590 1P-SP | 856 | 879 | 666 | 690 | 390 | 413 | 3894 | 3824 | 2070 | 3060 | 2104 | 1054 | 3366 | |
| 660 1P-SP | 870 | 900 | 685 | 714 | 415 | 444 | 4028 | 3958 | 2070 | 3060 | 2104 | 1058 | 3332 | |
| 470 2P-SP | 797 | 796 | 569 | 568 | 342 | 340 | 3411 | 3348 | 2070 | 2056 | 2056 | 1034 | 2605 | |
| 540 2P-SP | 822 | 820 | 591 | 589 | 360 | 357 | 3538 | 3475 | 2070 | 2056 | 2056 | 1033 | 2593 | |
| 590 2P-SP | 840 | 882 | 669 | 711 | 421 | 463 | 3985 | 3915 | 2070 | 3060 | 2104 | 1067 | 3291 | |
| 660 2P-SP | 851 | 903 | 689 | 741 | 454 | 506 | 4142 | 4072 | 2070 | 3060 | 2104 | 1074 | 3242 | |
| 470 1P-SP T | 924 | 650 | 891 | 616 | 857 | 582 | 4520 | 3457 | 2070 | 2056 | 2056 | 846 | 2117 | |
| 540 1P-SP T | 950 | 674 | 912 | 637 | 875 | 599 | 4647 | 3584 | 2070 | 2056 | 2056 | 851 | 2122 | |
| 590 1P-SP T | 950 | 718 | 963 | 731 | 982 | 750 | 5094 | 4024 | 2070 | 3060 | 2104 | 894 | 2709 | |
| 660 1P-SP T | 965 | 739 | 982 | 756 | 1006 | 781 | 5228 | 4158 | 2070 | 3060 | 2104 | 901 | 2700 | |
| 470 2P-SP T | 908 | 652 | 897 | 640 | 885 | 629 | 4611 | 3548 | 2070 | 2056 | 2056 | 862 | 2062 | |
| 540 2P-SP T | 934 | 676 | 919 | 661 | 904 | 646 | 4738 | 3675 | 2070 | 2056 | 2056 | 866 | 2068 | |
| 590 2P-SP T | 934 | 721 | 966 | 752 | 1013 | 799 | 5185 | 4115 | 2070 | 3060 | 2104 | 907 | 2645 | |
| 660 2P-SP T | 945 | 741 | 986 | 782 | 1045 | 842 | 5342 | 4272 | 2070 | 3060 | 2104 | 917 | 2626 | |

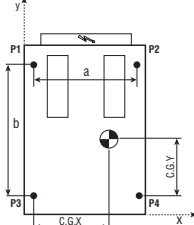
|  | SYS RE | Weight distribution (kg) | | | | Operating weight (kg) | Shipping weight (kg) | P1-P4 coordinates | | CG coordinates | |
|---|--------|--------------------------|-----|-----|------|-----------------------|----------------------|-------------------|--------|----------------|--------|
| | | P1 | P2 | P3 | P4 | | | a (mm) | b (mm) | x (mm) | y (mm) |
| | | 240 | 622 | 561 | 273 | | | 213 | 1670 | 2070 | 2056 |
| 270 | 623 | 562 | 274 | 213 | 1671 | 2070 | 2056 | 997 | 2041 | 725 | |
| 290 | 656 | 594 | 301 | 239 | 1790 | 2070 | 2056 | 1001 | 2019 | 1975 | |
| 320 | 660 | 597 | 304 | 241 | 1802 | 2070 | 2056 | 1000 | 2018 | 1948 | |
| 360 | 765 | 763 | 330 | 328 | 2185 | 2070 | 3060 | 1072 | 2723 | 2694 | |
| 420 | 802 | 802 | 346 | 346 | 2296 | 2070 | 3060 | 1073 | 2722 | 2693 | |

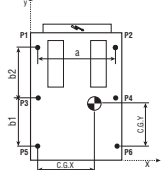
|  | SYS RE | Weight distribution (kg) | | | | | | Operating weight (kg) | Shipping weight (kg) | P1-P6 coordinates | | | CG coordinates | |
|---|--------|--------------------------|-----|-----|-----|-----|------|-----------------------|----------------------|-------------------|---------|---------|----------------|--------|
| | | P1 | P2 | P3 | P4 | P5 | P6 | | | a (mm) | b1 (mm) | b2 (mm) | x (mm) | y (mm) |
| | | 470 | 742 | 699 | 479 | 436 | 217 | | | 174 | 2747 | 2070 | 2056 | 2056 |
| 540 | 764 | 720 | 499 | 454 | 234 | 189 | 2860 | 2070 | 2056 | 2056 | 987 | 2818 | 2739 | |
| 590 | 774 | 773 | 571 | 570 | 275 | 274 | 3237 | 2070 | 3060 | 2104 | 1034 | 3547 | 3457 | |
| 660 | 793 | 793 | 587 | 587 | 287 | 287 | 3333 | 2070 | 3060 | 2104 | 1035 | 3534 | 3448 | |

8 - Technical Data (continued)

8.6 Dimensions SyScroll Air 240-270-290-320

Front view

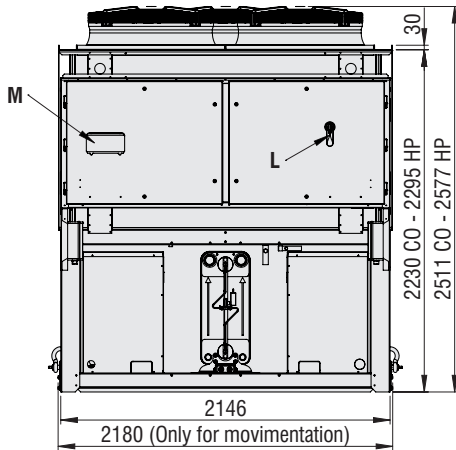

Side view

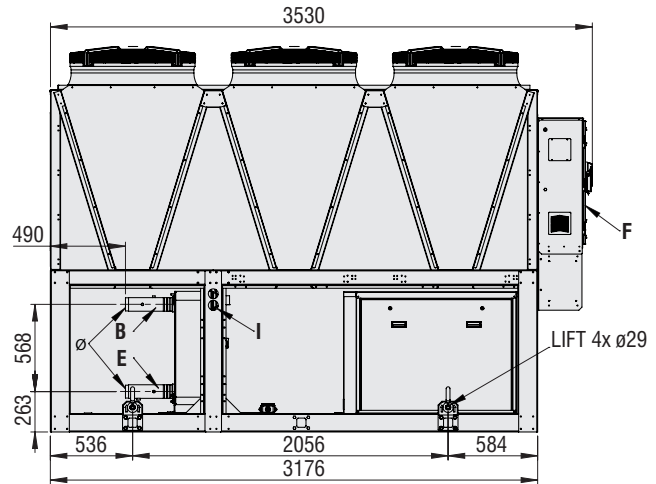

Back view

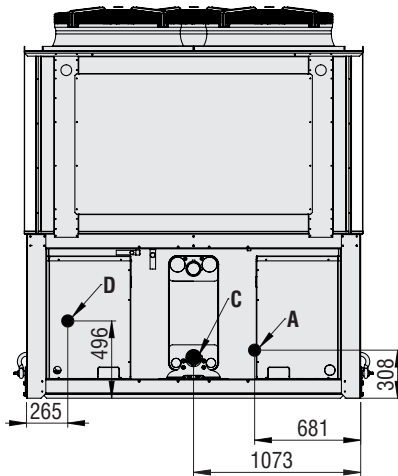

Top view

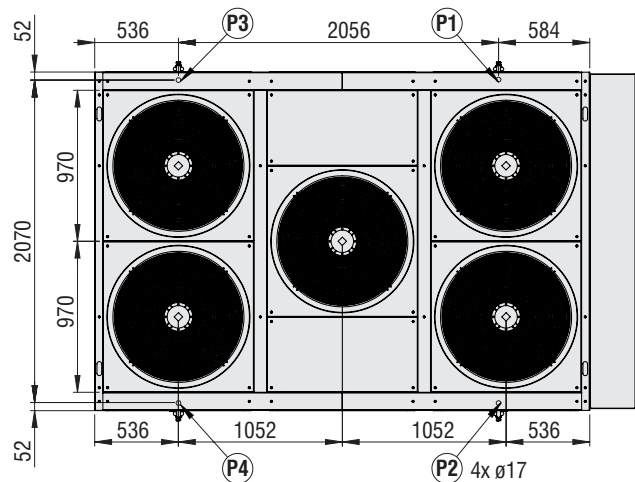

| | |
|-----------------------|-------------------------------------|
| A, B, C, D, E | Water connection 3" GAS M ø 88,9 mm |
| F | Electrical power supply |
| I | Gauge kit (Accessory) |
| L | Main switch |
| M | Control keypad / display |
| P1, P2, P3, P4 | Anti-vibration mount position |

| Hydraulic option | Water in | Water out |
|------------------|----------|-----------|
| STD | B | E |
| 1P/2P | A | C |
| 1PT/2PT | A | D |

8 - Technical Data (continued)

Dimensions SyScroll Air 360-420

Front view

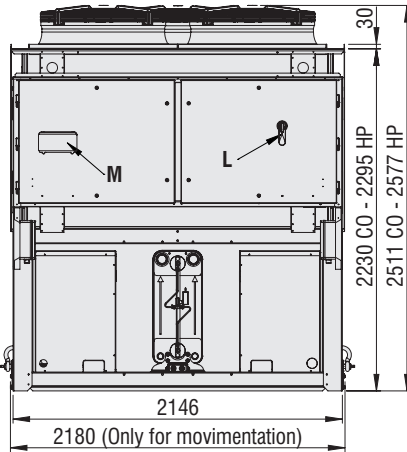

Side view

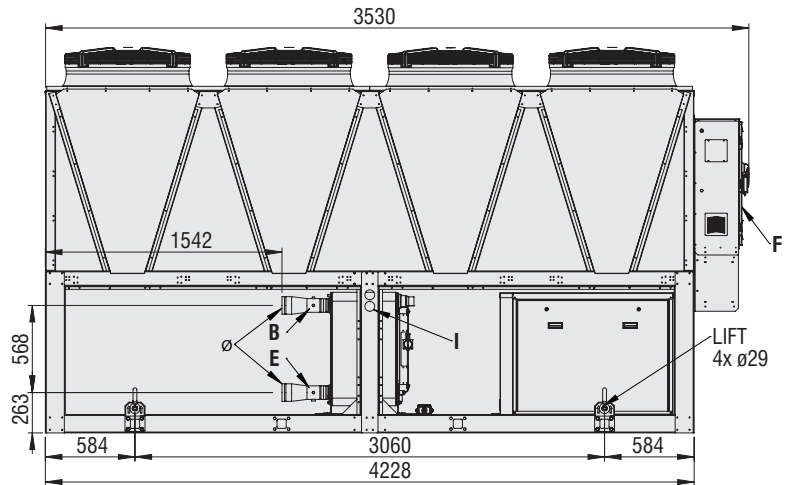

Back view

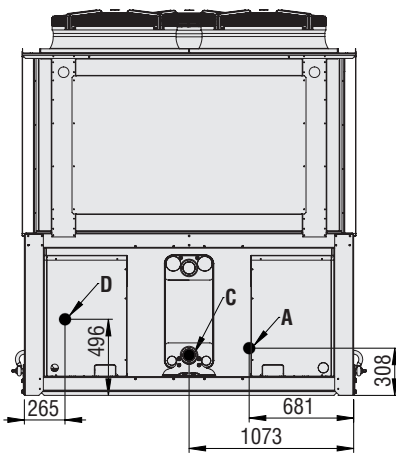

Top view

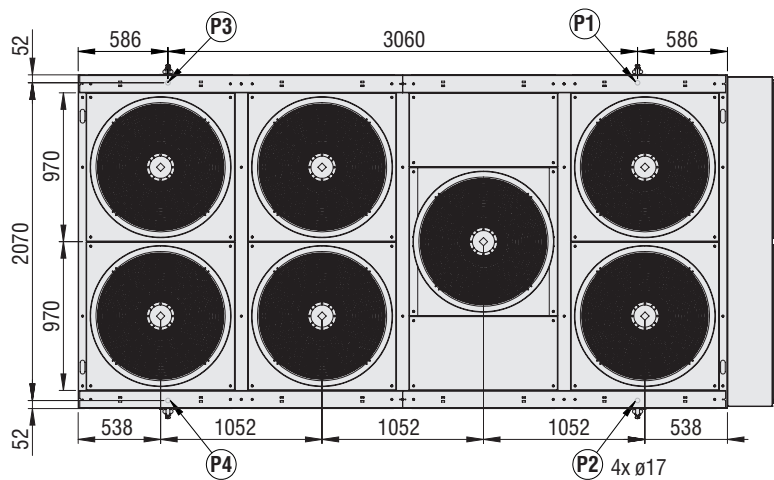

| | |
|-----------------------|--|
| A, B, C, D, E | Water connection 4" Victaulic \varnothing 114.3 mm |
| F | Electrical power supply |
| I | Gauge kit (Accessory) |
| L | Main switch |
| M | Control keypad / display |
| P1, P2, P3, P4 | Anti-vibration mount position |

| Hydraulic option | Water in | Water out |
|------------------|----------|-----------|
| STD | B | E |
| 1P/2P | A | C |
| 1PT/2PT | A | D |

8 - Technical Data (continued)

Dimensions SyScroll Air 470-540

Front view

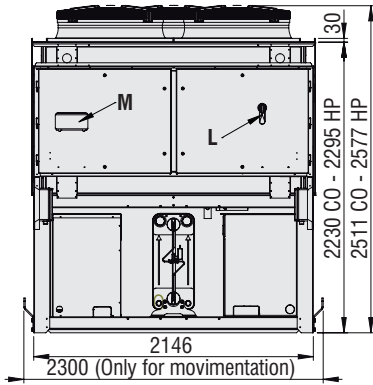

Side view

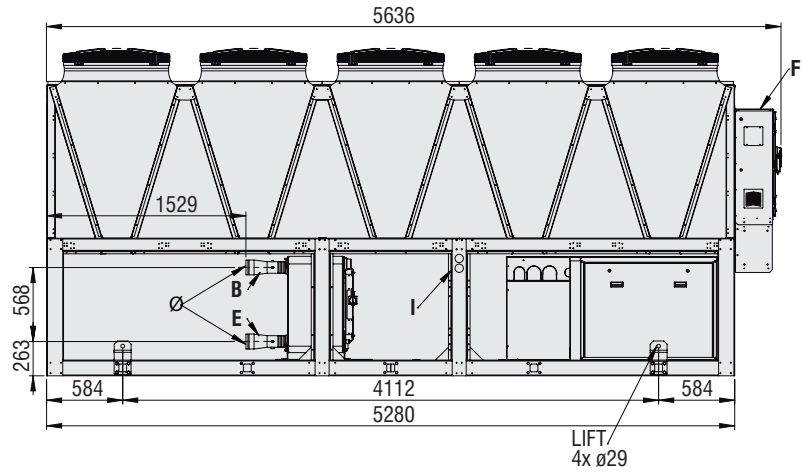

Back view

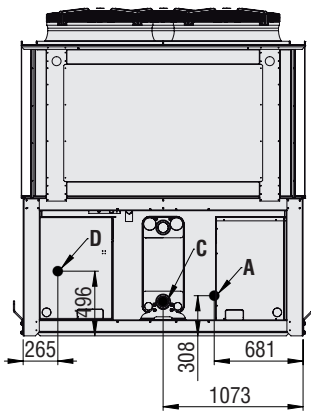

Top view

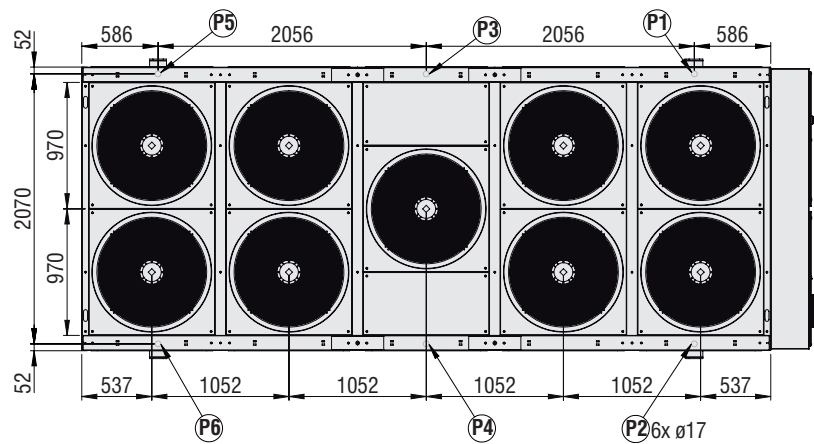

| | |
|----------------|--|
| A, B, C, D, E | Water connection 4" Victaulic \varnothing 114.3 mm |
| F | Electrical power supply |
| I | Gauge kit (Accessory) |
| L | Main switch |
| M | Control keypad / display |
| P1, P2, P3, P4 | Anti-vibration mount position |

| Hydraulic option | Water in | Water out |
|------------------|----------|-----------|
| STD | B | E |
| 1P/2P | A | C |
| 1PT/2PT | A | D |

8 - Technical Data (continued)

Dimensions SyScroll Air 590-660

Front view

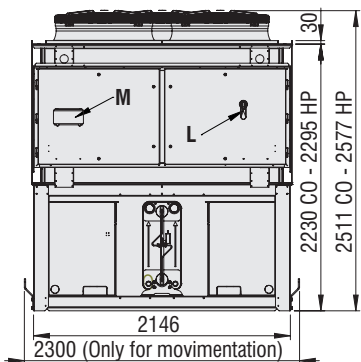

Side view

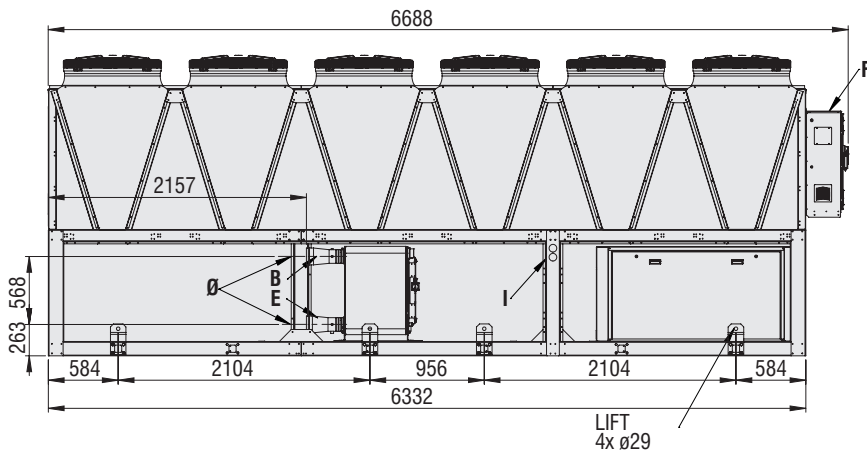

Back view

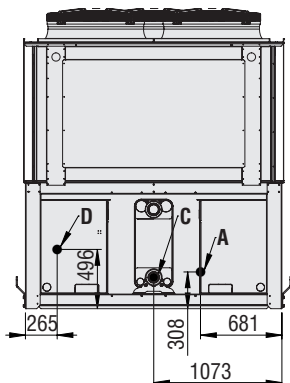

Top view

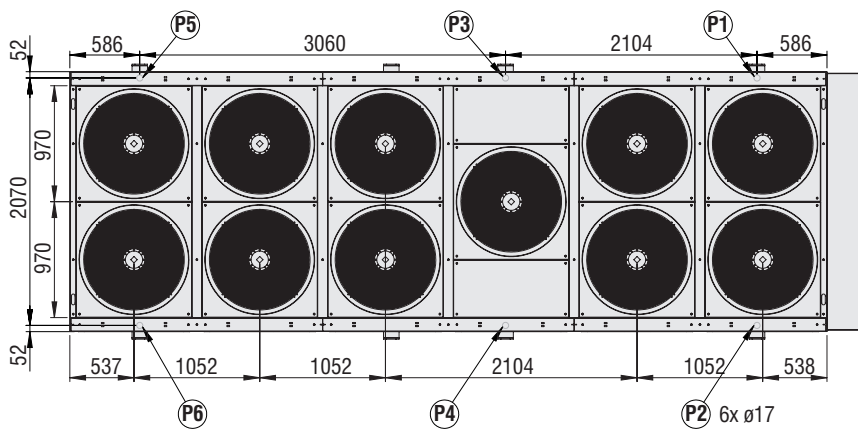

| | |
|----------------|--|
| A, B, C, D, E | Water connection 5" Victaulic \varnothing 141.3 mm |
| F | Electrical power supply |
| I | Gauge kit (Accessory) |
| L | Main switch |
| M | Control keypad / display |
| P1, P2, P3, P4 | Anti-vibration mount position |

| Hydraulic option | Water in | Water out |
|------------------|----------|-----------|
| STD | B | E |
| 1P/2P | A | C |
| 1PT/2PT | A | D |

8 - Technical Data (continued)

8.7 Space requirements

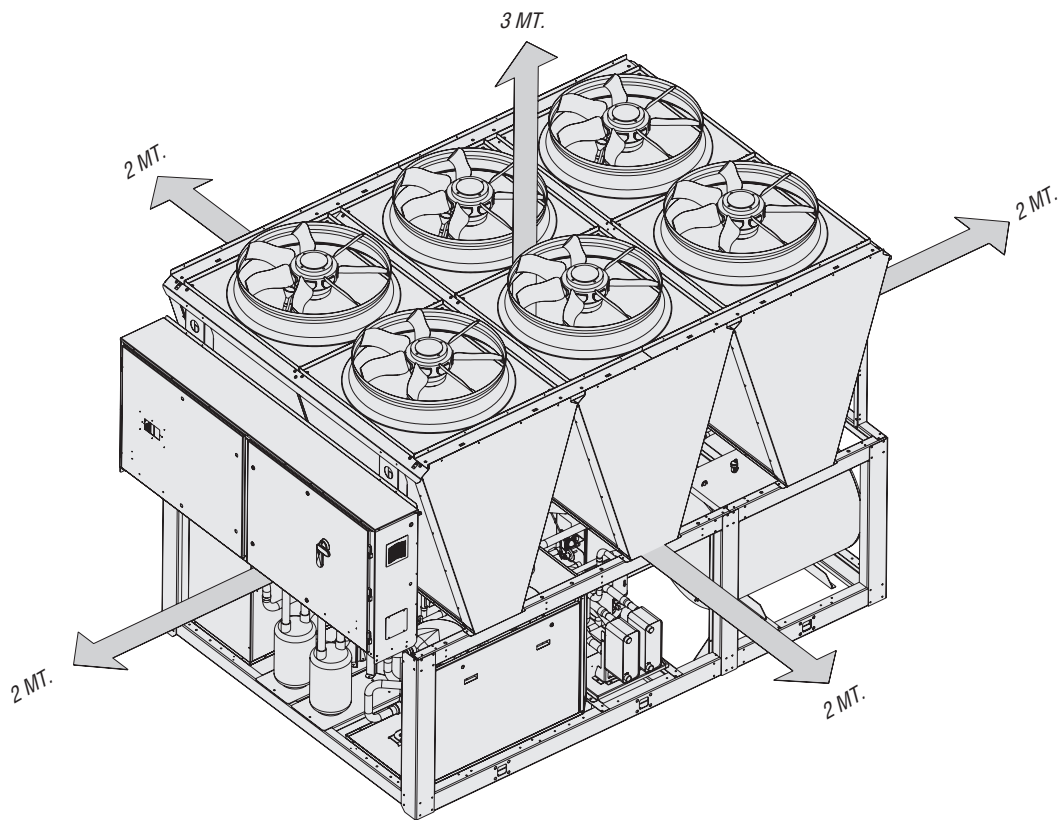

9 - Maintenance

Carefully read the “Safety” section of this manual before carrying out any maintenance operations.

| | |
|---|---|
|  | <p>Do not discharge the refrigerant into the atmosphere while the refrigeration circuits are being drained. Use appropriate recovery equipment.</p> <p>When the recovered refrigerant cannot be re-used, return it to the manufacturer.</p> |
|---|---|

| | |
|---|---|
|  | <p>Do not throw away the waste oil of the compressor, because it contains refrigerant in solution.</p> <p>The waste oil must be returned to the manufacturer.</p> |
|---|---|

Unless otherwise specified, the operations described below may be carried out only by a trained maintenance operator.

9.1 General requirements

Units have been designed for continuous operation, providing that they are subjected to regular maintenance, within the limits specified in this manual. Each unit must be serviced according to the programme by the User/Customer, and must be inspected at regular intervals by the personnel of one authorised Service Centers.

It is the responsibility of the User to meet these maintenance requirements and/or to enter into an agreement with one of authorised Service Centers, so as to properly safeguard the operation of the appliance.

During the warranty period, in case of damage or failures caused by improper maintenance, manufacturer will not refund the costs incurred to repair the appliance in its original state.

The provisions of this section apply only to standard units; according to the order requirements, other documentation may be added, concerning any modifications or supplementary accessories.

9.2 Planned maintenance

Maintenance inspections must be carried out according to the program below, by a qualified person.

As a general rule, units cannot be repaired directly by the user, who shall not try to service or repair any failures or anomalies identified during daily inspections. If you are in doubt, please contact authorised Service Centre.

| Operations | Daily | Weekly | Monthly | Beginning of season | End of season |
|---|-------|--------|---------|---------------------|---------------|
| Check the temperature of the leaving fluid | ● | | | | |
| Check the pressure drops in the heat exchanger | | ● | | | |
| Check for electric absorption | | ● | | | |
| Check suction pressure and temperature | | ● | | | |
| Check delivery pressure and temperature | | ● | | | |
| Check the oil level in the compressor | | ● | | | |
| Check that there are no gas bubbles in the liquid line | | ● | | | |
| Check that the fins of the external coil are clean (if any) | | | ● | | |
| Check the operation of the oil heaters | | | ● | | |
| Check the remote control switches | | | ● | | |
| Check the operation of the LP pressure switch | | | | ● | |
| Check the operation of the HP pressure switch | | | | ● | |
| Check the insulation of the heat exchanger | | | | ● | |
| Check that terminals are tightened | | | | ● | |
| Check that the terminals' screws are tightened | | | | ● | |
| Clean the exterior of the unit with water and soap | | | | ● | |
| Check the density of the antifreeze (if any) | | | | ● | ● |
| Check the operation of the flow switches | | | | ● | |
| Check the operation of the solenoid valve | | | | ● | ● |

9 - Maintenance (continued)

9.3 Refrigerant charge

Do not inject refrigerant liquid into the LP side of the circuit. Be very careful, and charge the circuit properly. If the charge is insufficient, the efficiency of the unit will be lower than expected. (In the worst of cases the LP transducer may stop the unit.)

In the presence of an excess charge, the condensing pressure will rise (in the worst of cases, the HP pressure switch may be activated, resulting in the stop of the equipment), and the consumption will increase as well.

It is strictly forbidden to use the compressor as a vacuum pump to drain the plant.

Fill the refrigeration circuit after it has been drained for maintenance purposes (leaks, replacement of the compressor etc.). The amount of the charge is indicated on the plate affixed to the unit.

Before refilling, it is important to drain and de-hydrate the circuit, thus obtaining a minimum abs. pressure value of 50 Pa.

Inject the refrigerant fluid before removing the vacuum, then fill the circuit up to 90% of the total gas requirement (in liquid form). The appliance must be filled through the filling valve on the liquid line, on the outlet side of the condenser.

It is recommended to connect the refrigerant cylinder to the filling valve on the liquid line, and to arrange it in such a way as to inject only liquid refrigerant.

9.4 Compressor

Compressors are delivered with the necessary charge of lubricating oil. During normal operation, this charge is sufficient for the whole life of the unit, providing that the efficiency of the refrigeration circuit is satisfactory and if it has not been overhauled.

If the compressor needs to be replaced (following a mechanical failure or if burnt), contact one of authorised Service Centers.

Compressors use POE/PVE oil. During maintenance operations on the compressor, or if you have to open the refrigerant circuit in any point, remember that this type of oil is highly hygroscopic, and accordingly it is important that it is not left exposed to the weather for prolonged periods, as this would require the replacement of the oil.

9.5 Condenser

The condenser's coils consist of copper pipes and aluminium fins. In the presence of leaks caused by any damage or shock, the coils shall be repaired or replaced by one of authorised Service Centers. To ensure the effective and correct operation of the condenser coils, it is important to keep the condenser's surface perfectly clean, and to check that there is no foreign matter, such as leaves, wires, insects, waste etc. If the coil becomes dirty, there is an increase in the absorption of electric energy. Furthermore, the maximum pressure alarm may be activated and may halt the unit.

Be careful not to damage the aluminium fins during cleaning.

The condenser must be cleaned with a LP compressed air jet, parallel to the aluminium fins, in the direction opposite to the air circulation.

To clean the coil you can use also a vacuum cleaner, or a jet of water and soap.

9.6 Fans

The fans of the condenser, of axial type, are complete with impeller with aerodynamic profile blades and a cylindrical nozzle. The motor's bearings are lubricated forever.

9.7 Dehydrating filter

The refrigeration circuits are provided with dehydrating filters.

The filter clogging is marked by the presence of air bubbles in the sight glass, or by the difference between the temperatures measured downstream from and upstream of the drying filter. If, once the cartridge has been cleaned, there are still some air bubbles, the appliance has lost a part of the refrigerant charge in one or more points, that must be identified and serviced.

9.8 Sight glass

The sight glass is used for inspecting the refrigerant flow and the humidity % of the refrigerant. The presence of bubbles indicates that the dehydrating filter is clogged or the charge insufficient.

A colour indicator is positioned inside the sight glass. If you compare the colour of the indicator to the scale on the ring of the sight glass, you can calculate the percentage of humidity of the refrigerant. If it is excessive, replace the filter's cartridge, operate the appliance for 1 day and then check the humidity % again. When the humidity % is within the pre-determined range, no other operations are required. If the humidity % is still too high, replace the dehydrating filter again, start the unit and operate it for another day.

9 - Maintenance (continued)

9.9 Electronic Expansion Valve

The circuit of the unit is equipped with electronic expansion valve, with external equalizer. The valve is shop-calibrated for an overheating of 5°C.

Procedure to check for overheating:

- Measure the suction pressure with the pressure gauges on the board of the unit or using a pressure gauge connected to the service valve on the suction side.

- From the pressure gauge's temperature scale, measure the saturated suction temperature (T_{sa}) which corresponds to the pressure value.

- Using a contact pressure gauge affixed to the outlet fitting of the gas of the evaporator, measure the actual temperature (T_{se}).

Overheating calculation (S):

$$S = T_{se} - T_{sa}$$

Overheating is regulated through the electronic expansion valve.

If the expansion valve cannot be regulated, it is probably broken, and shall be replaced. The replacement must be carried out by a Service Centre.

9.10 Evaporator

Check at regular intervals that the water side of the heat exchanger is perfectly clean. To do this, measure the pressure drop, water side (see Section 8) or measure the temperature of the liquid leaving and entering the heat exchanger, and compare it to the evaporation temperature.

To obtain an effective heat exchange, the difference between the temperature of the leaving water and the saturated evaporating temperature must be in the 2 - 4°C range. A greater difference would indicate a low efficiency of the heat exchanger (i.e. the heat exchanger is dirty).

In this case, the heat exchanger must be subjected to chemical cleaning, an operation that shall be carried out by authorised engineers.

For other maintenance operations (extraordinary overhauling, replacement of the heat exchanger etc.), contact an authorised Service Centre.

10 - Troubleshooting

The table below lists the anomalies of operation of the unit, the relevant causes and the corrective measures. For anomalies of any other type or not listed, contact one of authorised Service Centre for technical assistance.

| Anomaly | Cause | Operation |
|--|--|--|
| The unit continues to work, but without cooling | Insufficient charge of refrigerant. | Refill. |
| | The dehydrating filter is clogged. | Replace. |
| Ice on the suction line | Wrong calibration of overheating. | Increase overheating. |
| | | Check the charge. |
| Excessive noise | Vibration of lines. | Check the clamping brackets, if any. |
| | Whistler emitted by the thermostatic expansion valve. | Refill. |
| | | Check the dehydrating filter. |
| Noisy compressor. | Seized bearings; replace the compressor. | |
| | Check that the compressor's locknuts are tightened. | |
| Low oil level in the compressor | One or more gas or oil leaks in the circuit. | Identify and remove leaks. |
| | Mechanical failure of the compressor. | Request the intervention of a Service Centre. |
| | Anomaly of the oil heater of the compressor's base. | Check the electric circuit and the resistor of the heater of the motor base, and replace defective components. |
| One or both compressors are not working | Breaking of the electric circuit. | Check the electric circuit and detect any ground dispersions and short circuits. Check fuses. |
| | Intervention of the HP pressure switch. | Reset the pressure switch and the control panel and restart the appliance. Identify and remove the cause that enabled the pressure switch. |
| | The fuse of the control circuit is broken. | Check for ground dispersions and short circuits. Replace fuses. |
| | Loosened terminals. | Check and tighten. |
| | Halt caused by thermal overload of the electric circuit. | Check the operation of check and safety devices. Identify and remove the cause. |
| | Wrong wiring. | Check wiring of check and safety devices. |
| | The line voltage is too low. | Check voltage. If problems regard the system, solve them. If they are caused by the distribution network, inform the Energy Distributor. |
| | Short-circuit of the compressor's motor. | Check the continuity of the winding. |
| Seized compressor. | Replace the compressor. | |
| Activation of the LP alarm, stop of the unit | Gas leak. | Identify and remove the leak. |
| | Insufficient charge. | Refill. |
| | Failure of the pressure switch. | Replace the pressure switch. |
| Activation of the HP alarm, stop of the unit | Failure of the pressure switch. | Check the operation of the pressure switch, replace it if defective. |
| | The delivery valve is partially closed. | Open the valve and replace it, if faulty. |
| | Substances with condensable gases in the circuit. | Drain the circuit. |
| | The fan of the condenser is stopped. | Check cables and motor. If defective, repair or replace. |
| The liquid line is too hot | Insufficient charge. | Identify and remove the cause of the loss of charge and refill. |
| Frosting of the liquid line | The valve of the liquid line is partially closed. | Check that valves are open. |
| | The liquid filter is clogged. | Replace the cartridge or the filter. |

11 - Spare Parts

11.1 Spare part list

The table below shows the list of spare parts recommended during the first two years of operation.

| Component | Number |
|-------------------------------|--------|
| Fan | 1 |
| Flow switch | 1 |
| High pressure transducer | 1 |
| Low pressure transducer | 1 |
| Expansion valve | 1 |
| Gas filter | 1 |
| 4 way valve | 1 |
| Electronic main board | 1 |
| Auxiliary circuit transformer | 1 |
| Compressor contactor | 2 |
| Pump contactor | 1 |
| Water sensor | 4 |
| Air sensor | 1 |
| Auxiliary contact | 4 |
| Driver EEV | 1 |
| Fuses | 4 |

11.2 Oil for compressors

The compressors are lubricated with POE / PVE oil.

11.3 Wiring diagrams

The wiring diagrams are installed inside the doors of the electrical panels of the unit. Any request for wiring diagrams shall be forwarded to manufacturer's Service Centre.

12 - Dismantling, Demolition and Scrapping



During the draining of the refrigeration circuits, do not let the refrigerant overflow in the surrounding atmosphere.

The circuit must be drained using suitable recovery equipment.



Do not disperse the waste oil of the compressors in the environment, since it contains some dissolved refrigerant.

For the disposal, contact the competent authority for information.

Unless otherwise specified, the maintenance operations listed below may be carried out by any trained maintenance operator.

12.1 Generalities

Open each line that supplies the unit, including the ones of control circuits. Make sure that all disconnecting switches are secured in the off position. The power cables can be disconnected and disassembled. Refer to Chapter 4 for the position of connection points.

Remove all the refrigerant from the refrigeration circuits of the unit and store it in suitable containers, using a recovery unit. If its characteristics have remained the same, the refrigerant can be used again. Contact the competent authority to obtain information about disposal. In **NO** event shall the refrigerant be discharged into the atmosphere. The oil in each refrigeration circuit must be drained and collected into a suitable container; then it shall be disposed of in conformity with local regulations that apply to the disposal of waste lubricants. Any oil spillage must be recovered and disposed of in like manner.

Isolate the unit's heat exchangers from the external hydraulic circuits and drain the heat exchange sections of the plant.



If no shutoff valves have been provided, it may be necessary to drain the whole plant.

If a glycoled solution or a similar fluid has been used in the hydraulic circuits, or if chemical additives have been added to the circulating water, the circulating fluid MUST be drained in a proper way.

For NO reason shall a circuit containing glycoled water or a similar solution be discharged directly into the drains or surface waters.

After draining operations, the piping of the hydraulic networks can be disconnected and disassembled.

Once they have been disconnected as specified, the packaged units can be disassembled in a single piece. First of all, disassemble the anchoring screws and then lift the unit from the position of installation, and hook it to the lifting points provided, using suitable lifting equipment.

To this end, refer to Chapter 4 for the installation of these appliances, to Chapter 8 for their weights and Chapter 3 for handling.

The units that, once disconnected, cannot be removed in a single piece, must be dismantled on site; in this case, be very careful with the weight and handling of every single component.

It is always advisable to dismantle the units following the installation steps, but in reverse.



Some residues of oil, glycoled water or similar solutions may remain in certain parts of the unit. These residues must be recovered and disposed of according to the procedures specified above.

It is very important to ensure that, while a component of the unit is being removed, all the others are properly supported.



Use only lifting means of adequate capacity.

Once disassembled, the components of the unit can be disposed of in conformity with current regulations.

BUONE NORME DI MANUTENZIONE DEI DISPOSITIVI DI SICUREZZA MONTATI SUL GRUPPO FRIGORIFERO

Gentile Cliente,

Le ricordiamo alcune indicazioni circa le modalità di manutenzione dei dispositivi di sicurezza montati sul gruppo frigorifero da Lei acquistato.

I dispositivi di sicurezza montati sul gruppo sono stati verificati dal COSTRUTTORE a norma di legge.

È opportuno che l'utente provveda periodicamente (è consigliato ogni anno) a far verificare da personale qualificato la taratura ed il corretto intervento dei dispositivi di sicurezza montati sul gruppo.

In particolare la taratura della/e valvole di sicurezza dovrebbe essere verificata al banco intercettando opportunamente il circuito e/o il refrigerante e registrando l'avvenuta verifica sulla scheda di manutenzione del gruppo frigorifero (a disposizione dei tecnici CE/PED che eventualmente ne prenderanno visione).

L'utente avrà cura di conservare efficienti ed in buono stato l'evaporatore ed i suoi accessori e provvederà ad eventuali sostituzioni degli stessi con altri di tipo analogo.

In caso di sostituzione, la valvola di sicurezza e i pressostati di alta pressione dovranno avere caratteristiche equivalenti a quelle fornite e rilasciate con certificato CE/PED.

Si consiglia in occasione della verifica delle valvole di sicurezza di far controllare il corretto intervento dei pressostati di alta pressione.

Per informazioni circa le modalità operative, la strumentazione e la scelta di personale qualificato, è possibile contattare IL COSTRUTTORE.

IMPORTANT NOTICE – Maintenance instructions

Please read carefully the following instructions for the maintenance of safety devices fitted on this refrigeration machine.

All safety devices fitted on the machine by MANUFACTURE have been checked and tested in accordance with European Regulations.

The machine has been designed to operate continuously provided it is regularly maintained and operated within the limitations given in the "Installation, Commissioning, Operation and Maintenance Manual". The unit should be maintained in accordance with the schedule by the operator/customer, backed up regular service and maintenance visit by an authorised service Centre.

It is the responsibility of the owner to provide for these regular maintenance requirements by a competent person. If in any doubt contact your local Service Centre.

In particular, all safety valves where fitted and safety pressure switches should be tested and calibrated. Where necessary test certificate provided by a certified authority must be retained as a record together with the Maintenance Log.

Date: 18/01/2012

Nazareno Mantovani

Service Director



As part of our ongoing product improvement programme, our products are subject to change without prior notice. Non contractual photos.

Dans un souci d'amélioration constante, nos produits peuvent être modifiés sans préavis. Photos non contractuelles.

In dem Bemühen um ständige Verbesserung können unsere Erzeugnisse ohne vorherige Ankündigung geändert werden. Fotos nicht vertraglich bindend.

A causa della politica di continua miglioria posta in atto dal costruttore, questi prodotti sono soggetti a modifiche senza alcun obbligo di preavviso. Le foto pubblicate non danno luogo ad alcun vincolo contrattuale.

Con objeto de mejorar constantemente, nuestros productos pueden ser modificados sin previo aviso. Fotos no contractuales.

